

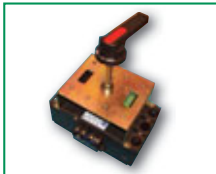

Kompakte Leistungsschalter, KM 2



Drehantrieb 4



Modulare kompakte Leistungsschalter (MKM) 6



NT Sicherungen mit Messerkontakten 8



Sicherungsunterteile 10

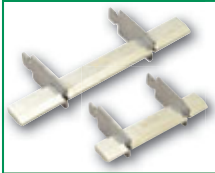

Kurzschlussmesser 11



Sicherungs-Lasttrennschalter (für Zylindrische Sich.) 12



Sicherungs-Lasttrennschalter, horizontal, Aufbau 14



Sicherungs-Lasttrennschalter, horizontal, Sammelschiener-Montage 15



Sicherungs-Lasttrennschalter, vertikal, Sammelschiener-Montage (185 mm Schienenmitteabstand) 16



COSMO Sammelschiensystem mit 60 mm Schienenmitteabstand 18

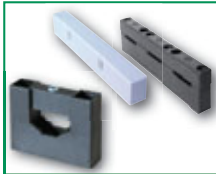

Sammelschienträger und Abdeckungen (60 mm Schienenmitteabstand) 18



Anschlussklemmen 18



Prismenklemme 19

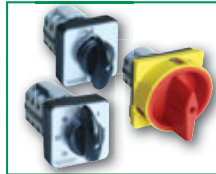

TK Industrielle Handschalter 20

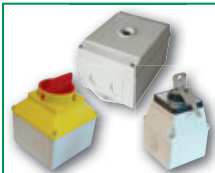

Gehäuse 21

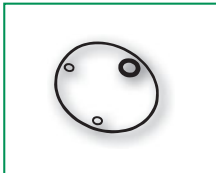

Abdichtungs-Set 21



Lasttrennschalter 29

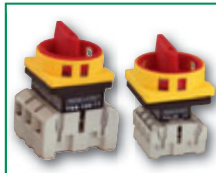

Absperrbare Sicherheits-Hauptschalter 30



Hilfsschütze 33



Schütze des Typs TR1D für allgemeine Anwendungen 34



TEMS Motorstarter Kombinationen in Gehäuse 36



Leistungsschütze für Hochstrom 38



Hilfsschalterbausteine (Aufbau) 40

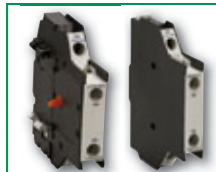

Hilfsschalterbausteine (Seitenanbau) 41



Zeitbausteine (Aufbau) 41

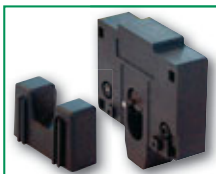

Mechanische Verriegelung 41

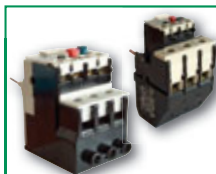

TR2H Thermische Überlastrelais 42



Handbetätigte Motorschutzschalter 46



Hilfskontakte (Aufbau) 48



Arbeitsstromauslöserblock 49



















Gehäuse 49

Piktogramme der Tabellenüberschriften

U_m Nenn Betätigungs- spannung	U_e Nenn-Betriebsspan- nung	I_{th} Thermischer Nennstrom (A)	 U_i Nenn-Isolationsspan- nung
I_e Nenn-Betriebsstrom	I_n Nennstrom (A)	I_{cu} Nenn-Betriebs-Kurz- schluss-Ausschaltver- mögen	I_s Stromaufnahme
I_m Einstellstrom des ther- mischen Auslösers (A)	P_e Schaltleistung	P_m Eigenverbrauch	P_s Anfahrleistung
P_{ON} Leistungsaufnahme -anziehen	P_{HOLD} Leistungsaufnahme -halten	 Lichtbogen Abstand (mm)	 Anzahl der Stromwandler
 Mechanische Lebensdauer	 Elektrische Lebens- dauer	 Kontakte	 Anordnung der Kontakte
 Hilfskontakte	 Kabeleinführung unten/oben	 Kabeleinführung unten	 Kabeleinführung oben
 A_{mm} Abmessung der Welle	 Schienenmittenab- stand	 Querschnitt der Schiene	 X Anzahl der Schrauben
 Empfohlene Vorsicherung	 Elektrische Kapazität	 Optisches Signal	 Einstellungszeit
 Mit Gehäuse, IP65	 Abmessungen (L × W × H)	 mm² Klemmquerschnitt	 Bemerkungen, Ergänzungen
 Eindrätig, mehrdrät- tig, feindrätig Ader	 Gewicht		

Piktogramme der technischen Daten

U_m 230 V AC	U_e 660 V	 U_i 690 V	U_{imp} 6 kV
U_{test} 1min 1,8 kV	I_{th} 1 A	I_e 2 A	I_{cu} 120 kA _{eff}
40/60 Hz	Class Ir 10A	 UVR	 SHT
P_m 5 VA	P_{ON} 30 VA	P_{HOLD} 4,5 VA	 10 A gG
 Magnetantrieb	 Motorantrieb	AC 6b	 Schwingungsfestigkeit
 Hilfskontakte	IP10	IP20	IP 65
 Lampenkörper der I. Berührungsschutz- klasse	ON-OFF-ON... sc/h x4.800	 Mechanische Lebens- dauer x10 ⁷	 Elektrische Lebens- dauer 6x10 ⁵
 Länge 350 mm	[mm²] Für Anschluss geeig- nete Leitung 2x1-2x6	 Schienenmontage 35x7.5	 auf eine vertikale Fläche (Wand), Abweichung bis ± 30° erlaubt
 Höhe über dem Meer 2000 m	To -5...+40°C	Ta -25...+65°C	 Relativ Feuchtigkeit max. 90

Kompakte Leistungsschalter, KM

230/400
V AC

50/60 Hz

U_i
690 V

U_{imp}
6 kV

T_o
-5...+40°C

T_a
-5...+55°C

2000 m

Piktogramme
I/O



Technische Daten der thermischen Auslöser

		I _{th max.}		I _e
KM1	1500	63 A	8500	32 A; 40 A; 50 A; 63 A
KM2	1500	100 A	8500	63 A; 80 A; 100 A
KM3	1000	160 A	7000	125 A; 140 A; 160 A
KM4	1000	225 A	7000	180 A; 200 A; 225 A
KM5	1000	350 A	7000	250 A; 315 A; 350 A
KM6	1000	630 A	4000	400 A; 500 A; 630 A
KM7	1000	800 A	4000	630 A; 700 A; 800 A

Technische Daten der elektromagnetischen Auslöser

	I _{th max.}	I _{cu}	
KM1	63 A	50 kA	0 mm
KM2	100 A	50 kA	0 (<50) mm
KM3	160 A	50 kA	0 (<50) mm
KM4	225 A	50 kA	<50 mm
KM5	350 A	50 kA	<50 mm
KM6	630 A	50 kA	100 mm
KM7	800 A	65 kA	100 mm

Temperaturabhängigkeit

Der Korrekturfaktor für die Belastbarkeit lässt sich mit Hilfe der Charakteristik in Abhängigkeit von der Betriebstemperatur ermitteln. Wenn die Umgebungstemperatur an der Montagestelle des Schutzschalters 40 °C übersteigt, muss die maximale Belastbarkeit unter Verwendung des Korrekturfaktors in der folgenden Tabelle bestimmt werden.

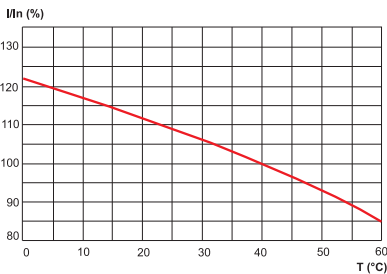

RELEVANT STANDARD
EN 60947-1

RELEVANT STANDARD
EN 60947-2

Korrekturfaktor

	T _a				
	40 – 45 °C	45 – 50 °C	50 – 55 °C	55 – 60 °C	60 – 65 °C
KM1	1,0	0,94	0,88	0,80	0,72
KM2	1,0	0,95	0,89	0,84	0,76
KM3	1,0	0,97	0,93	0,90	0,86
KM4	1,0	0,96	0,91	0,87	0,82
KM5	1,0	0,94	0,87	0,81	0,73
KM6	1,0	0,93	0,88	0,83	0,76
KM7	1,0	0,88	0,83	0,79	0,76

Auslösecharakteristik

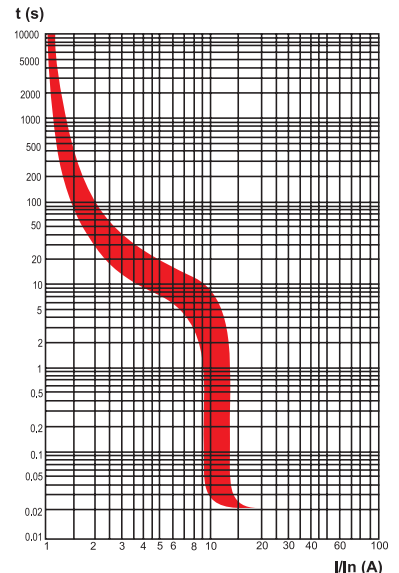

Hilfsschalterblöcke

Unterspannungsauslöserblock

U_m

P_m

230 V AC

2,3 – 3,8 VA

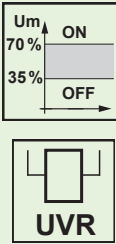
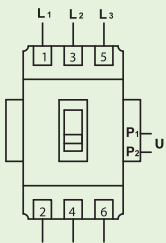

UVR

Der Unterspannungsauslöser bewirkt die Auslösung des Leistungsschutzschalters wenn an den Anschlussklemmen nur 35-70 % der Nennspannung anstehen. Der Auslöser verhindert die Einschaltung des Leistungsschutzschalters wenn die Spannung an den Klemmen 35 % des Nennwertes nicht erreicht.

Arbeitsstromauslöserblock (shunt)

U_m

230 V AC, 400 V AC, 220 V, DC

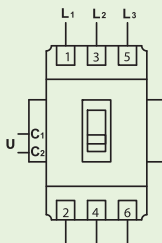

SHT

Mit Hilfe des Arbeitsstromauslösers kann der Leistungsschutzschalter fernbedient ausgeschaltet werden; die Auslösung erfolgt, wenn an den Anschlussklemmen 70-110 % der Nennbetriebsspannung vorhanden sind.

Hilfsschalterblock

U_e

I_e
AC-15

U_i

I_{th}

230 V AC

1,2 A

690 V

10 A gG 3 A

400 V AC

0,5 A

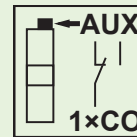

KM1-..
KM2-..
KM3-..
KM4-..

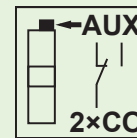

KM5-..
KM6-..
KM7-..

Kompakt-Leistungsschalter mit Hilfsschalter 1 Wechsler

TRACON	I_e		U_m
KM1-032/1A	32 A	SHT	230 V AC
KM1-032/1B	32 A	SHT	400 V AC
KM1-032/1C	32 A	SHT	220 V DC
KM1-032/2	32 A	UVR	230 V AC
KM1-040/1A	40 A	SHT	230 V AC
KM1-040/1B	40 A	SHT	400 V AC
KM1-040/1C	40 A	SHT	220 V DC
KM1-040/2	40 A	UVR	230 V AC
KM1-050/1A	50 A	SHT	230 V AC
KM1-050/1B	50 A	SHT	400 V AC
KM1-050/1C	50 A	SHT	220 V DC
KM1-050/2	50 A	UVR	230 V AC
KM1-063/1A	63 A	SHT	230 V AC
KM1-063/1B	63 A	SHT	400 V AC
KM1-063/1C	63 A	SHT	220 V DC
KM1-063/2	63 A	UVR	230 V AC
KM2-063/1A	63 A	SHT	230 V AC
KM2-063/1B	63 A	SHT	400 V AC
KM2-063/1C	63 A	SHT	220 V DC
KM2-063/2	63 A	UVR	230 V AC
KM2-080/1A	80 A	SHT	230 V AC
KM2-080/1B	80 A	SHT	400 V AC
KM2-080/1C	80 A	SHT	220 V DC
KM2-080/2	80 A	UVR	230 V AC
KM2-100/1A	100 A	SHT	230 V AC
KM2-100/1B	100 A	SHT	400 V AC

TRACON	I_e		U_m
KM2-100/1C	100 A	SHT	220 V DC
KM2-100/2	100 A	UVR	230 V AC
KM3-125/1A	125 A	SHT	230 V AC
KM3-125/1B	125 A	SHT	400 V AC
KM3-125/1C	125 A	SHT	220 V DC
KM3-125/2	125 A	UVR	230 V AC
KM3-140/1A	140 A	SHT	230 V AC
KM3-140/1B	140 A	SHT	400 V AC
KM3-140/1C	140 A	SHT	220 V DC
KM3-140/2	140 A	UVR	230 V AC
KM3-160/1A	160 A	SHT	230 V AC
KM3-160/1B	160 A	SHT	400 V AC
KM3-160/1C	160 A	SHT	220 V DC
KM3-160/2	160 A	UVR	230 V AC
KM4-180/1A	180 A	SHT	230 V AC
KM4-180/1B	180 A	SHT	400 V AC
KM4-180/1C	180 A	SHT	220 V DC
KM4-180/2	180 A	UVR	230 V AC
KM4-200/1A	200 A	SHT	230 V AC
KM4-200/1B	200 A	SHT	400 V AC
KM4-200/1C	200 A	SHT	220 V DC
KM4-200/2	200 A	UVR	230 V AC
KM4-225/1A	225 A	SHT	230 V AC
KM4-225/1B	225 A	SHT	400 V AC
KM4-225/1C	225 A	SHT	220 V DC
KM4-225/2	225 A	UVR	230 V AC

Kompakt-Leistungsschalter mit Hilfsschalter 2 Wechsler

TRACON	I _e		U _m
KM5-250/1A	250 A	SHT	230 V AC
KM5-250/1B	250 A	SHT	400 V AC
KM5-250/1C	250 A	SHT	220 V DC
KM5-250/2	250 A	UVR	230 V AC
KM5-315/1A	315 A	SHT	230 V AC
KM5-315/1B	315 A	SHT	400 V AC
KM5-315/1C	315 A	SHT	220 V DC
KM5-315/2	315 A	UVR	230 V AC
KM5-350/1A	350 A	SHT	230 V AC
KM5-350/1B	350 A	SHT	400 V AC
KM5-350/1C	350 A	SHT	220 V DC
KM5-350/2	350 A	UVR	230 V AC
KM6-400/1A	400 A	SHT	230 V AC
KM6-400/1B	400 A	SHT	400 V AC
KM6-400/1C	400 A	SHT	220 V DC
KM6-400/2	400 A	UVR	230 V AC
KM6-500/1A	500 A	SHT	230 V AC
KM6-500/1B	500 A	SHT	400 V AC

TRACON	I _e		U _m
KM6-500/1C	500 A	SHT	220 V DC
KM6-500/2	500 A	UVR	230 V AC
KM6-630/1A	630 A	SHT	230 V AC
KM6-630/1B	630 A	SHT	400 V AC
KM6-630/1C	630 A	SHT	220 V DC
KM6-630/2	630 A	UVR	230 V AC
KM7-630/1A	630 A	SHT	230 V AC
KM7-630/1B	630 A	SHT	400 V AC
KM7-630/1C	630 A	SHT	220 V DC
KM7-630/2	630 A	UVR	230 V AC
KM7-700/1A	700 A	SHT	230 V AC
KM7-700/1B	700 A	SHT	400 V AC
KM7-700/1C	700 A	SHT	220 V DC
KM7-700/2	700 A	UVR	230 V AC
KM7-800/1A	800 A	SHT	230 V AC
KM7-800/1B	800 A	SHT	400 V AC
KM7-800/1C	800 A	SHT	220 V DC
KM7-800/2	800 A	UVR	230 V AC

SHT: Shunt Relay / Arbeitsstromauslöser

UVR: Unterspannungsauslöser

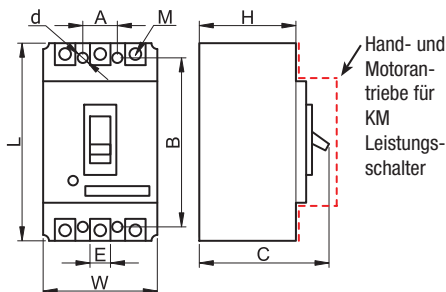

Abmessungen und Bohrungen für Befestigung



	W (mm)	L (mm)	H (mm)	C (mm)	A (mm)	B (mm)	E (mm)	M (mm)	d (mm)
KM1	78	136	74	98	25	117	13.5	M5	3.5
KM2	92	150	80	104	30	129	18	M8	4.5
KM3	107	165	98	127	35	126	23	M8	5
KM4	107	165	98	127	35	126	23	M8	5
KM5	150	257	98	155	44	194	32	M10	7
KM6	182	270	105	160	58	200	43	M12	7
KM7	210	280	98	142	70	243	43	M12	7

Drehantrieb



TRACON		A (mm)	B (mm)	H (mm)	
KM1-HM	KM1	102	25	50	8 × 8 / 150 mm
KM2-HM	KM2	104	30	53	8 × 8 / 150 mm
KM4-HM	KM3-KM4	142	35	56	8 × 8 / 150 mm
KM5-HM	KM5	194	138	94	10 × 10 / 150 mm
KM6-HM	KM6	200	168	96	10 × 10 / 150 mm
KM7-HM	KM7	240	195	85	10 × 10 / 150 mm

Der KM-HM Drehantrieb dient als Antrieb von Leistungsschaltern hinter einer Tür. Er besteht aus einem auf den Schalter gebauten Betätigungsteil, einer Antriebsachse und einem Drehgriff auf der Tür, der die ON-OFF Stellung des Leistungsschalters anzeigt. Die Tür kann aufgrund der mechanischen Türverriegelung in der ON-Position nicht geöffnet werden.

Bohrungen für Befestigung

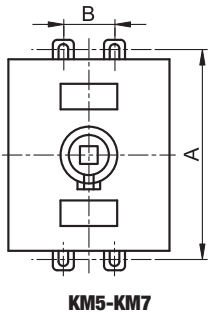

KM5-KM7

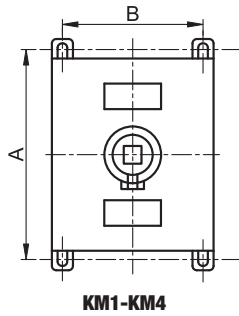

KM1-KM4

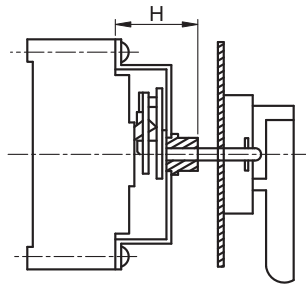

Drehantrieb

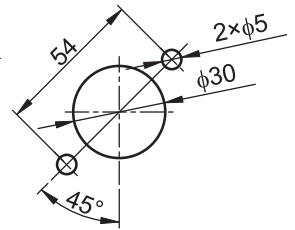

Fernantrieb, Motorantrieb



TRACON			I_s	P_s	A (mm)	B (mm)	H (mm)
KM1-PM		KM1	< 5 A	1100 W	102	25	92
KM2-PM		KM2	< 7 A	1540 W	104	30	92
KM4-PM		KM3-KM4	< 8,5 A	1870 W	142	35	100
KM5-PM			KM5	< 5,7 A	1200 W	194	44
KM6-PM	KM6		< 5,7 A	1200 W	200	58	140
KM7-PM	KM7		< 7,5 A	2000 W	240	70	140

Ermöglicht das Schalten von Leistungsschaltern aus der Ferne oder Handschaltung vor Ort mit zwei Drucktastern. Der elektrische Antrieb besteht aus einem, auf dem Leistungsschalter montierten Betätigungsteil und einem Handantrieb. Die ON-OFF Schaltung ist bei den Typen KM1-KM4 magnetisch, bei den Grössen KM5-KM7 motorisch. (Verdrahtungsplan siehe im Anhang)

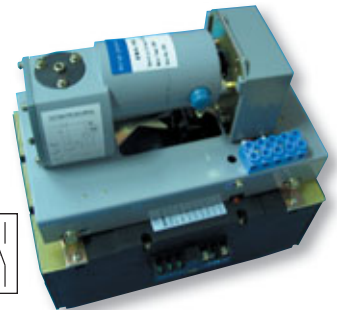

Magnetantrieb



Motorantrieb

Schaltplan und Abmessungen

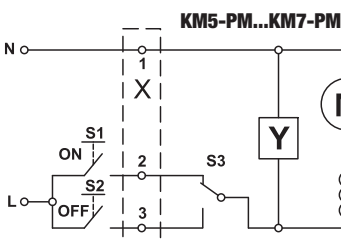
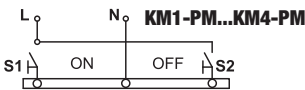

Legende

- M - Motor
- Y - Elektrische Bremse
- S3 - Mikroschalter
- X - Klemme
- S1, S2 - Druckknopf

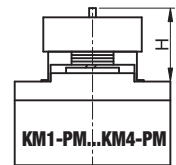
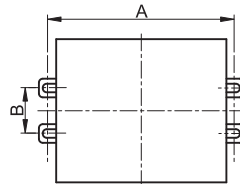

KM1-PM...KM4-PM

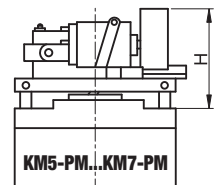

KM5-PM...KM7-PM

Kompakte Leistungsschalter, MKM

230/400
V AC

50/60 Hz

U_i
500 V

U_{imp}
6 kV

3P

T_o
-5...+40°C

T_a
-25...+65°C

2000 m



Piktogramme

I/O



	MKM1	MKM2
I_e (A)	15, 20, 25, 30, 40, 50, 60, 75, 80, 100	125, 160, 225, 250
I_{cu} (kA _{eff}) AC	220/240 V	85
	380 V	18
	400 V	15
I_{cs}/I_{cu} (%)	220/240 V	50 %
	380 V	50 %
	400 V	50 %
ON-OFF-ON... sc/h	× 10	× 5
$\text{⚡} \text{⌚} (\times 10^5)$	8.500	8.500
$\text{⚡} \text{⌚} (\times 10^5)$	4.000	4.000
m	0,78 kg	1,3 kg

TRACON	I_e	TRACON	I_e	TRACON	I_e	TRACON	I_e
MKM1-15	15 A	MKM1-40	40 A	MKM1-80	80 A	MKM2-225	225 A
MKM1-20	20 A	MKM1-50	50 A	MKM1-100	100 A	MKM2-250	250 A
MKM1-25	25 A	MKM1-60	60 A	MKM2-125	125 A		
MKM1-30	30 A	MKM1-75	75 A	MKM2-160	160 A		

Abmessungen (MKM1)

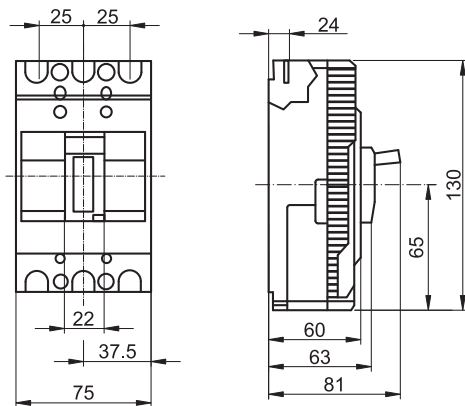

Abmessungen (MKM2)

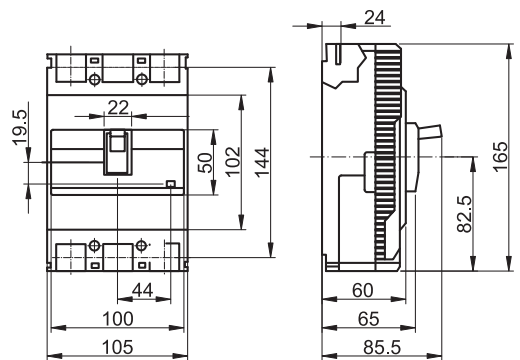

LESEN SIE DIESEN CODE

- Sehen Sie unsere Neuigkeiten an!
- Bleiben Sie auf dem Laufenden.

Unsere Lieferprogramm vergrößert sich schnell und fortlaufend. Bitte verfolgen Sie die Neuheiten auf unserer Webseite. Dieser Katalog enthält unser Lieferprogramm Stand April 2019.



Hilfsschalter- und Signalkontakt- Blöcke

Typ	Function
Hilfsschalterblöcke:	Information über die Position des Hauptkontaktes des Leistungsschalters
Signalkontakt-Blöcke:	Meldung über Ausschaltung des Gerätes aufgrund eines Kurzschlusses, Überlastung oder Handauslösung.
Hilfsschalter / Signalkontakt- Blöcke:	Diese Blöcke integrieren die zwei oben genannten Funktionen für komplexere Steuerungsaufgaben

I_{th} 1 A	AC 15	I_e 0,8 A	 350 mm
------------------------------	-----------------	-------------------------------	---



MKM-AX

TRACON	Function		
MKM-AX100	Hilfsschalterblock	MKM1-..	0,25 mm ²
MKM-AX250	Hilfsschalterblock	MKM2-..	0,35 mm ²
MKM-AL100	Signalkontakt-Block	MKM1-..	0,25 mm ²
MKM-AL250	Signalkontakt-Block	MKM2-..	0,35 mm ²
MKM-AXAL100	Hilfsschalter /Signalkontakt-Block	MKM1-..	0,25 mm ²
MKM-AXAL250	Hilfsschalter /Signalkontakt-Block	MKM2-..	0,35 mm ²





MKM-AL

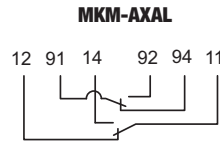
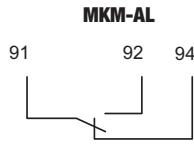
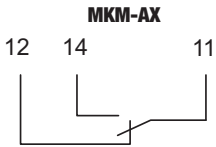

MKM-AXAL



Arbeitsstromauslöser

TRACON		P ON 	
MKM-SHT1-230	MKM1-..	<30 VA	0,25 mm ²
MKM-SHT2-230	MKM2-..		0,35 mm ²



U_m 230 V AC

 350 mm



Mit Hilfe des Arbeitsstromauslösers wird die Fernsteuerung des Leistungsschalters ermöglicht. Der SHT1-230 Typ kann an beiden Seiten des Geräts; der SHT2-230 Typ kann nur an der rechten Seite installiert werden.

Der Auslöser schaltet das Gerät bei 70% der Betätigungsspannung aus. Die Steuerspannung darf nur max. 1 s anstehen.

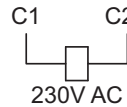

Bohrungen für Befestigung

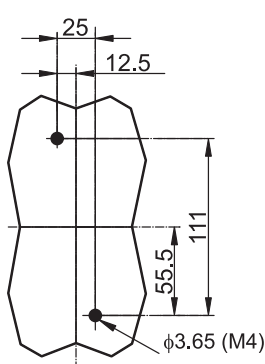

MKM1

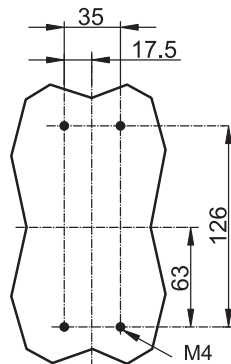

MKM2

Stellungen des Knebels

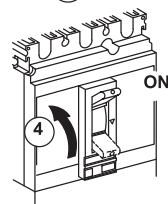
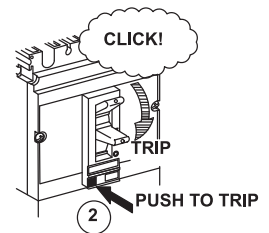
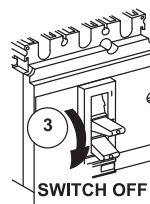
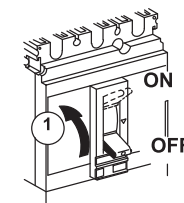

NT Sicherungen mit Messerkontakten

500 V AC I_{cu} 120 kA_{eff} IP 00 Ta -5...+55 °C 2000 m

Piktogramme I/O



NT	I _n	P _v
00C	6-160 A	7,5 W
00	2-160 A	12 W
0	6-160 A	16 W
1	32-250 A	23 W
2	50-400 A	34 W
3	160-630 A	48 W

Material des Gehäuses: steatit
Material des Schmelzeleiters: Kupfer(mit Silber)

Im Falle von Überlast oder Kurzschluss unterbricht die Sicherung den Stromkreis und schützt nachfolgende Geräte. Der Einsatz spart Kosten obwohl die Sicherungen nach jedem Ansprechen ausgewechselt werden müssen, sie brauchen keine Wartung, sind nicht feuer- oder explosionsgefährlich und können durch Austausch des Schmelzelements an die Belastung angepasst werden.

Die Sicherungen des Typs NT ... sind mit dem Symbol „gG“ gekennzeichnet. Damit wird die Ausdehnung der Unterbrechungsfähigkeit über den gesamten Bereich der allgemeinen Anwendungen verstanden wird. (Die frühere VDE-Norm hat das Symbol „gL“ benutzt.)

Die Schmelzelemente mit Unterbrechungsfähigkeiten zum Schutz der E-Motoren geeigneten Bereich werden mit dem Symbol „aM“ gekennzeichnet.

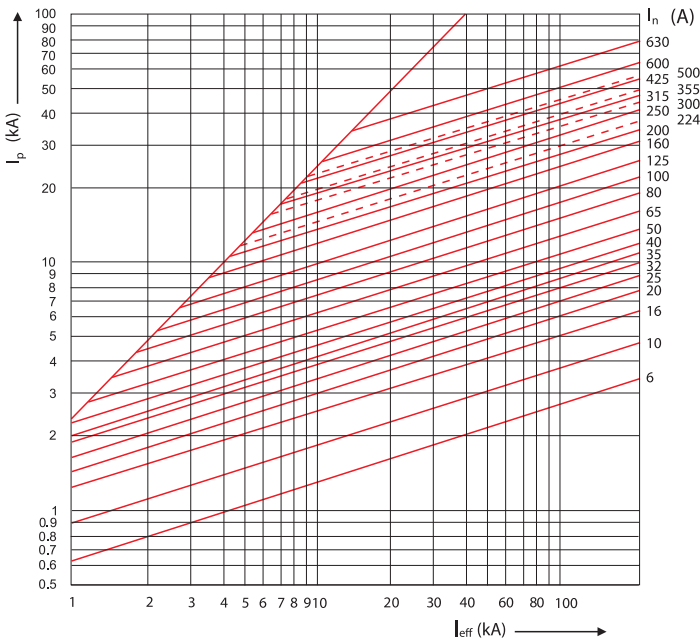

RELEVANT STANDARD
EN 60269-1
HD 60269-2

Die strombegrenzende Wirkung der Sicherung zeigt das Diagramm, untenstehend. An der vertikalen Achse ist der Effektivwert des unabhängigen Kurzschlussstroms, an der horizontalen Achse der Spitzenstromwert sichtbar.

z.B.: bei Sicherung (100 A): wenn der Effektivwert des unabhängigen Kurzschluss - stroms 20 kA ist, dann kann der maximale Spitzenstrom zirka 11 kA sein.

Sortiment

Sicherungseinsätze, Grösse „00C“

TRACON		I _n
gG	aM	
NT00C-6	-	6 A
NT00C-10	-	10 A
NT00C-16	-	16 A
NT00C-20	-	20 A
NT00C-25	-	25 A
NT00C-32	-	32 A
NT00C-40	-	40 A
NT00C-50	-	50 A
NT00C-63	-	63 A
NT00C-80	-	80 A
NT00C-100	-	100 A
NT00C-125	-	125 A
NT00C-160	-	160 A

Sicherungseinsätze, Grösse „00“

TRACON		I _n
gG	aM	
-	NTM00-2	2 A
NT00-4	NTM00-4	4 A
NT00-6	NTM00-6	6 A
NT00-10	NTM00-10	10 A
NT00-16	NTM00-16	16 A
NT00-20	NTM00-20	20 A
NT00-25	NTM00-25	25 A
NT00-32	NTM00-32	32 A
NT00-40	NTM00-40	40 A
NT00-50	NTM00-50	50 A
NT00-63	NTM00-63	63 A
NT00-80	NTM00-80	80 A
NT00-100	NTM00-100	100 A
NT00-125	NTM00-125	125 A
NT00-160	NTM00-160	160 A

Sicherungseinsätze, Grösse „0“

TRACON		I _n
gG	aM	
NT0-6	NTM0-6	6 A
NT0-10	NTM0-10	10 A
NT0-16	NTM0-16	16 A
NT0-20	NTM0-20	20 A
NT0-25	NTM0-25	25 A
NT0-32	NTM0-32	32 A
NT0-40	NTM0-40	40 A
NT0-50	NTM0-50	50 A
NT0-63	NTM0-63	63 A
NT0-80	NTM0-80	80 A
NT0-100	NTM0-100	100 A
NT0-125	NTM0-125	125 A
NT0-160	NTM0-160	160 A

Sicherungseinsätze, Grösse „1“

TRACON		I _n
gG	aM	
NT1-32	-	32 A
NT1-40	-	40 A
NT1-50	-	50 A
NT1-63	-	63 A
NT1-80	NTM1-80	80 A
NT1-100	NTM1-100	100 A
NT1-125	NTM1-125	125 A
NT1-160	NTM1-160	160 A
NT1-200	NTM1-200	200 A
NT1-224	-	224 A
NT1-250	NTM1-250	250 A

Sicherungseinsätze, Grösse „2“

TRACON		I _n
gG	aM	
NT2-50	-	50 A
NT2-63	-	63 A
NT2-80	-	80 A
NT2-100	-	100 A
NT2-125	NTM2-125	125 A
NT2-160	NTM2-160	160 A
NT2-200	NTM2-200	200 A
NT2-224	NTM2-224	224 A
NT2-250	NTM2-250	250 A
-	NTM2-300	300 A
NT2-315	NTM2-315	315 A
NT2-355	NTM2-355	355 A
NT2-400	NTM2-400	400 A

Sicherungseinsätze, Grösse „3“

TRACON		I _n
gG	aM	
NT3-160	-	160 A
NT3-200	-	200 A
NT3-315	NTM3-315	315 A
NT3-355	NTM3-355	355 A
NT3-400	NTM3-400	400 A
NT3-425	NTM3-425	425 A
NT3-500	NTM3-500	500 A
NT3-630	NTM3-630	630 A

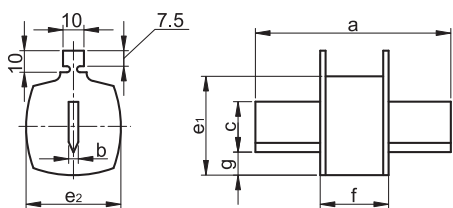

RELEVANT STANDARD
EN 60269-1
HD 60269-2

Abmessungen



NT	a (mm)	f (mm)	g (mm)	c (mm)	e ₁ (mm)	e ₂ (mm)	b (mm)
00C	78±1.5	54-6	11.5	15	45	20	6
00	78±1.5	54-6	11.5	15	45	29	6
0	125±2.5	68-8	11.5	15	45	29	6
1	135±2.5	75-10	12	21	48	48	6
2	150±2.5	75-10	13	27	58	58	6
3	150±2.5	75-10	14	33	67	67	6

Sicherungsunterteile

TRACON			A (mm)	B (mm)	C (mm)	D (mm)	E (mm)	F (mm)	G (mm)	H (mm)	K (mm)	M (mm)
	NTA-00C-00	00C, 00	120	100	25	8	30	25	60	56	–	8
	NTA-0	0	170	150	25	8	35	30	64	74	–	8
	NTA-1	1	200	175	25	12	49	32	85	80	30	10
	NTA-2	2	224	200	25	12	49	32	86	80	30	10
	NTA-3	3	235	210	25	12	49	32	88	80	30	12
	NTA-00/3	00C, 00	132	100	–	8	100	24	58	56,5	70	8

TRACON



NTA-00C-00 ... NTA-3:

Kontakte und Kunststoff-Grundplatte ist selbstverlöschend und hitzebeständig;
Klemmen und Kontakte sind eingearbeitet.

NTA-00/3:



NTA-00C-00, NTA-0



NTA-1, NTA-2



NTA-3



NTA-00/3

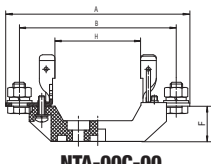

NTA-00C-00

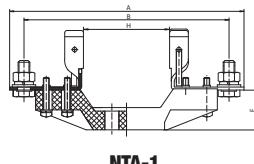

NTA-1

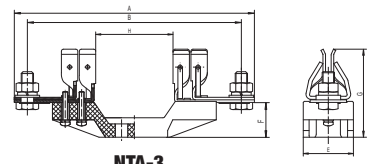

NTA-3

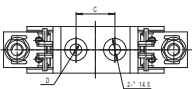

NTA-0

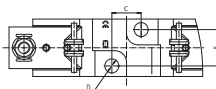

NTA-2

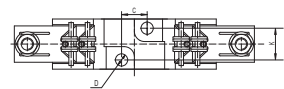

NTA-00/3

Kurzschlussmesser

TRACON		a (mm)	b (mm)	c (mm)	d (mm)
NTR00	00C,00	45	15	45±1.5	78±1.5
NTR0	0	46	15	62±3	125±2.5
NTR1	1	51	20	62±3	135±2.5
NTR2	2	56	25	62±3	150±2.5
NTR3	3	62	32	65±3	150±2.5

Kurzschlussmesser werden vorrangig für die Trennung der Nulleiter eingesetzt.

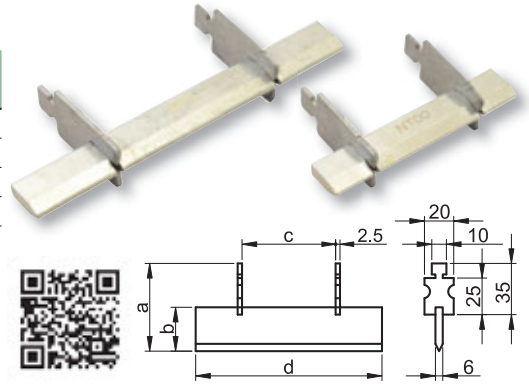

Aufsteckzange für Sicherungseinsätze

TRACON		
NTK	1000 V	00C...3

Mit der Aufsteckzange können Sicherungseinsätze in ihre Unterteile eingesteckt bzw. getrennt werden (in spannungsfreiem Zustand). Die Aufsteckzangen sind auch als Trennmittel zu verwenden, da sie den Stromkreis sicher und gut sichtbar unterbrechen.



Flutlichtstrahler



E1/12-E1/21

Sicherungs-Lasttrennschalter (für Zylindrische Sich.)



230/400 V AC	IP 20	35x7.5	T_a -25...+55°C	U_i 690 V	V0 UL94	50/60 Hz	2000 m
-----------------	-----------------	--------	-------------------------------------	-------------------------------	-------------------	----------	--------



- Einspeisung von oben oder unten.
- gG (normal), aM (Motor) Kennlinie für Zylindrische Sicherungen
- Genietetes Gehäuse
- Mehrphasen-Ausführung
- Bemessungs-Ausschaltvermögen bis AC 500 V; 100 kA
AC 690 V; 50 kA
- Nicht brennbares Kunststoffgehäuse
- EN 60269-Serie

RELEVANT STANDARD
EN 60947-1

RELEVANT STANDARD
EN 60947-3

TRACON	xP	I_n (A)	mm ²		
HBA-1P-20	1P	20 A	1,5-6	8 × 32 mm	
HBA-2P-20	2P	20 A	1,5-6	8 × 32 mm	
HBA-3P-20	3P	20 A	1,5-6	8 × 32 mm	
HBA-1P-32	1P	32 A	1,5-6	10 × 38 mm	-
HBA-2P-32	2P	32 A	1,5-6	10 × 38 mm	
HBA-3P-32	3P	32 A	1,5-6	10 × 38 mm	
HBA-1P-50	1P	50 A	1,5-25	14 × 51 mm	
HBA-2P-50	2P	50 A	1,5-25	14 × 51 mm	
HBA-3P-50	3P	50 A	1,5-25	14 × 51 mm	
HBA-1P-100	1P	100 A	1,5-25	22 × 58 mm	
HBA-2P-100	2P	100 A	1,5-25	22 × 58 mm	
HBA-3P-100	3P	100 A	1,5-25	22 × 58 mm	

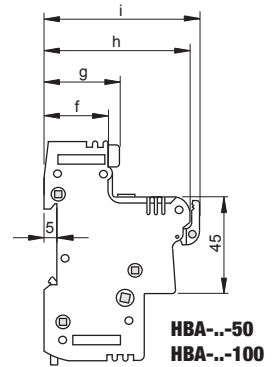
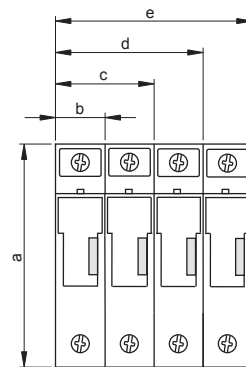
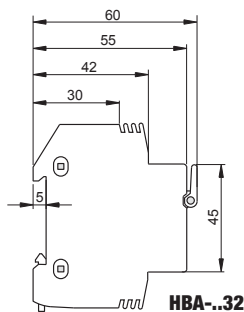
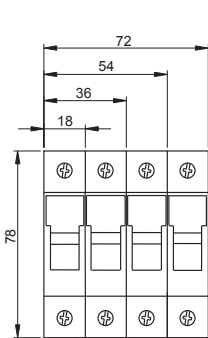

	a (mm)	b (mm)	c (mm)	d (mm)	e (mm)	f (mm)	g (mm)	h (mm)	i (mm)
HBA-...-50	107	27	54	81	108	31	39	72.5	77.5
HBA-...-100	113	35.5	71	106.5	142	31	39	72.5	77.5

Zylindrische Sicherung

8x32 mm

TRACON		I _n
gG	aM	
HB-8x32-2	HBM-8x32-2	2 A
HB-8x32-4	HBM-8x32-4	4 A
HB-8x32-6	HBM-8x32-6	6 A
HB-8x32-8	HBM-8x32-8	8 A
HB-8x32-10	HBM-8x32-10	10 A
HB-8x32-16	HBM-8x32-16	16 A

14x51 mm

TRACON		I _n
gG	aM	
HB-14x51-2	HBM-14x51-2	2 A
HB-14x51-4	HBM-14x51-4	4 A
HB-14x51-6	HBM-14x51-6	6 A
HB-14x51-8	HBM-14x51-8	8 A
HB-14x51-10	HBM-14x51-10	10 A
HB-14x51-16	HBM-14x51-16	16 A
HB-14x51-20	HBM-14x51-20	20 A
HB-14x51-25	HBM-14x51-25	25 A
HB-14x51-32	HBM-14x51-32	32 A
HB-14x51-40	HBM-14x51-40	40 A
HB-14x51-50	HBM-14x51-50	50 A

	D (mm)	L (mm)
8x32	8,5	31,5
10x38	10,3	38
14x51	14,3	51
22x58	22,2	58

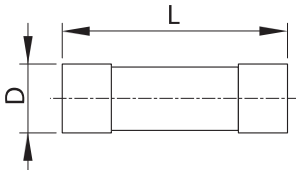

RELEVANT STANDARD
EN 60947-1

RELEVANT STANDARD
EN 60947-3

10x38 mm

TRACON		I _n
gG	aM	
HB-10x38-1	HBM-10x38-1	1 A
HB-10x38-2	HBM-10x38-2	2 A
HB-10x38-4	HBM-10x38-4	4 A
HB-10x38-6	HBM-10x38-6	6 A
HB-10x38-8	HBM-10x38-8	8 A
HB-10x38-10	HBM-10x38-10	10 A
HB-10x38-16	HBM-10x38-16	16 A
HB-10x38-20	HBM-10x38-20	20 A
HB-10x38-25	HBM-10x38-25	25 A
HB-10x38-32	HBM-10x38-32	32 A

22x58 mm

TRACON		I _n
gG	aM	
HB-22x58-10	HBM-22x58-10	10 A
HB-22x58-16	HBM-22x58-16	16 A
HB-22x58-20	HBM-22x58-20	20 A
HB-22x58-25	HBM-22x58-25	25 A
HB-22x58-32	HBM-22x58-32	32 A
HB-22x58-40	HBM-22x58-40	40 A
HB-22x58-50	HBM-22x58-50	50 A
HB-22x58-63	HBM-22x58-63	63 A
HB-22x58-80	HBM-22x58-80	80 A
HB-22x58-100	HBM-22x58-100	100 A



LESEN SIE DIESEN CODE

- Sehen Sie unsere Neuigkeiten an!
- Bleiben Sie auf dem Laufenden.

Unsere Lieferprogramm vergrößert sich schnell und fortlaufend. Bitte verfolgen Sie die Neuheiten auf unserer Webseite. Dieser Katalog enthält unser Lieferprogramm Stand April 2019.

Horizontaler Typ Sicherungs-Lasttrennschalter für Aufbaumontage



Die Jean Müller KETO Sicherungs-Lasttrennschalter und die COSMO® Sammelschienen-Systeme sowie das Zubehör, die ausführlichen technischen Daten, Abmessungen finden Sie in TRACON extrahierten Katalog und im Webshop.

Die Abmessungen und detaillierte Technische Daten der Messer-Sicherungs-Lasttrennschalter finden Sie auf www.traconelectric.com!

- Schraube (A) oder Rahmenklemme (B)
- 1-, 2-, 3-, 4-polige Versionen
- Vier Baugrößen für 00, 1, 2 und 3 Typ NH Sicherungen
- Nachrüstbare, universelle Anschlussarten



TRACON	I_n				mm ²	L (mm)	W (mm)	H (mm)	U _i	U _e
KETO-00-1/F	160	00	A	max. 95, M10	204	50	84	800 VAC	690 VAC, 440 VDC	
KETO-00-1/R95			B	1,5-95	204	50	84	800 VAC	690 VAC, 440 VDC	
KETO-1-1/F	250	1	A	max. 150, M10	306	69	117	800 VAC	690 VAC, 440 VDC	
KETO-3-1/F			A	max. 300, M10	306	91	143	800 VAC	690 VAC, 440 VDC	
KETO-00-3/F	160 A	00	A	max. 95, 1×M8/2×M5	204	106	84	800 VAC	690 VAC, 440 VDC	
KETO-00-3/R95			B	1,5-95	204	106	84	800 VAC	690 VAC, 440 VDC	
KETO-1-3/F	250 A	1	A	max. 150, M10	306	184	117	800 VAC	690 VAC, 440 VDC	
KETO-1-3/R150			B	35-150	306	184	117	800 VAC	690 VAC, 440 VDC	
KETO-2-3/F	400 A	2	A	max. 240, M10	306	210	117	800 VAC	690 VAC, 440 VDC	
KETO-2-3/R300			B	95-300	306	210	117	800 VAC	690 VAC, 440 VDC	
KETO-3-3/F	630 A	3	A	max. 300, M10	306	250	117	800 VAC	690 VAC, 440 VDC	
KETO-3-3/R300			B	95-300	306	250	117	800 VAC	690 VAC, 440 VDC	

FRAGEN SIE UNSEREN KUNDENDIENST ODER VERTRETER NACH UNSEREM KATALOG



VOLLSTÄNDIGE AUSWAHL!

- Anschlussklemmen
- Anschlußschienen 00
- Berührungsschutz elemente
- Hutschienenadapter
- Abschließvorrichtung
- Schaltstellungsanzeige
- Sicherungsüberwachungen
- Stromdiebstahlsicherung
- Technische Daten
- Maßzeichnungen



Horizontaler Typ Sicherungs-Lasttrennschalter für Sammelschienen-Montage

Diese Geräte passen auf dreipolige Sammelschienen-Systeme mit 60 und 100 mm Schienenmittenabstand, sind einfach zu montieren, auch als Nachrüstung.

Die Montageelemente hinter den Schienen pressen die Kontaktflächen des Geräterückens an die Sammelschienen, so wird auch die passende Stromversorgung und die Fixierung sichergestellt.

- 3-polige Typen für Kabel- und Schienenanschluss
- für 60 mm und 100 mm Schienenmittenabstand
- 5-10 mm Schienendicke
- Vier Baugrößen für 00, 1, 2 und 3 Typ NH Sicherungen

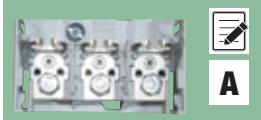

TRACON	H	In		a	b	a x b		mm ²	L (mm)	W (mm)	H (mm)
KETO-00-3/60/AOU/F	60 mm	160 A	00	20-30	5-10	A	max. 95, 1xM8/2xM5	204	106	109	
KETO-00-3/60/AOU/R95	60 mm	160 A	00	20-30	5-10	B	1,5-95	204	106	109	
KETO-00-3/60/AOU/R95T*	60 mm	160 A	00	20-30	5-10	B	1,5-95	204	106	109	
KETO-1-3/60/AOU/F	60 mm	250 A	1	20-30	5-10	A	max. 150, M10	306	184	117	
KETO-1-3/60/AOU/R150	60 mm	250 A	1	20-30	5-10	B	35-150	306	184	117	
KETO-2-3/60/AOU/F	60 mm	400 A	2	20-30	5-10	A	max. 240, M10	306	210	135	
KETO-2-3/60/AOU/R300	60 mm	400 A	2	20-30	5-10	B	95-300	306	210	135	
KETO-3-3/60/AOU/F	60 mm	630 A	3	20-30	5-10	A	max. 300, M10	306	250	143	
KETO-3-3/60/AOU/R300	60 mm	630 A	3	20-30	5-10	B	95-300	306	250	143	
KETO-1-3/100/AOU/F	100 mm	250 A	1	20-50	5-10	A	max. 150, M10	306	184	146	
KETO-2-3/100/AOU/F	100 mm	400 A	2	20-50	5-10	A	max. 240, M10	306	210	144	
KETO-3-3/100/AOU/F	100 mm	630 A	3	20-50	5-10	A	max. 300, M10	306	250	152	

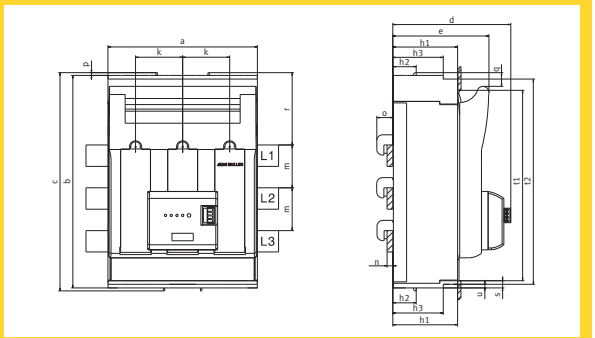

Seit der Gründung im Jahre 1897 ist Jean Müller ein dominanter Teilnehmer im Markt der Niederspannungs-Schaltgeräte. Die gute Qualität dieser Schaltgeräte ist weltweit anerkannt.

Vertikaler Typ Sicherungs-Lasttrennschalter für Sammelschienen-Montage (185 mm Schienenmittenabstand)

500/690
V AC

220/400
V DC

40/60 Hz

1 kV

IP10

IP20











Ta
-25...+55°C

 Piktogramme I/O













Spezifikation:
Kabelanschluss oben oder unten durch Drehung des Gerätes um 180°
Einfache Messung durch Prüflöcher in der Frontplatte

1-polig schaltbare Varianten

TRACON	I _n		 mm ²	L (mm)	W (mm)	H (mm)	
SL00-3X/185/F	160 A	00	Max. 95	662	50	135,5	
SL00-3X/185/KU00	160 A	00	10 – 95	662	50	135,5	
SL1-3X/3A	250 A	1	25 – 150	762	99	194	
SL1-3X/9/KM2G-F	250 A	1	25 – 240	762	99	194	
SL2-3X/3A	400 A	2	25 – 240	762	99	194	
SL2-3X/9/KM2G-F	400 A	2	25 – 240	762	99	194	
SL3-3X/3A	630 A	3	25 – 300	762	99	194	
SL3-3X/9/KM2G-F	630 A	3	25 – 240	762	99	194	

3-polig schaltbare Varianten

TRACON	I _n		 mm ²	L (mm)	W (mm)	H (mm)	
SL00-3X3/185/F	160 A	00	Max. 95	662	50	150	
SL00-3X3/185/KU00	160 A	00	10 – 95	662	50	150	
SL1-3X3/3A	250 A	1	25 – 150	762	99	202	
SL1-3X3/9/KM2G-F	250 A	1	25 – 240	762	99	202	
SL2-3X3/3A	400 A	2	25 – 240	762	99	202	
SL2-3X3/9/KM2G-F	400 A	2	25 – 240	762	99	202	
SL3-3X3/3A	630 A	3	25 – 300	762	99	202	
SL3-3X3/9/KM2G-F	630 A	3	25 – 240	762	99	202	

Schalthebel

- Langer Schalthebel für sicheres und schnelles Schalten
- Abschliessbar mit bis zu 3 Vorhängeschlössern in EIN- und AUS-Stellung bei 1-polig schaltbaren Varianten

Messung und Überwachung

- Sichere Spannungsmessung durch Prüflöcher über den Sicherungsaufnahmekontakten

Montage

- Sichere Montage, sogar unter Spannung, durch Berührungsschutz Wählbarer Anschluss oben oder unten, abhängig von der Lage des Gerätes
- Nachrüstbare Montagehaken für Sammelschienen-Montage



Zubehör für Aufbau der Sammelschienensysteme mit 100 und 185 mm Schienenmittenabstand

SH100/185

Sammelschienenenträger (für 100 und 185 mm Sammelschienensysteme)



Die Sammelschienenenträger sind geeignet für die Befestigung von Sammelschienen mit 100 und 185 mm Schienenmittenabstand. Damit kann ein optimales Sammelschienensystem auch für Vertikale Sicherungs-Lasttrennschalter aufgebaut werden. Zusammen mit den Abdeckungen kann ein vollisoliertes Schienensystem aufgebaut werden.

Technische Daten:

- Pohlzahl: 3
- Grösse der Fixierungs-schraube: M12
- Sammelschienenbreite: 100 mm
- Schienenmittenabstand: 100 oder 185 mm
- Abmessungen: 38×442×25 mm

H-SL123/662

Sammelschienenabdeckung, schraubbar (für 185 mm Sammelschienensysteme)



Mit dieser Frontabdeckung kann der Berührungsschutz der 3-phasigen Sammelsysteme mit 185 mm Schienenmittenabstand an der Frontseite sichergestellt werden.

Technische Daten:

- Pohlzahl: 3
- Fixierungsschrauben: Kunststoff mit Clips
- Sammelschienenbreite: 100 mm
- Schienenmittenabstand: 185 mm
- Abmessungen: 100×662×2 mm

H-RF

Sammelschienenabdeckung, schnappbar (für 100 und 185 mm Sammelschienensysteme)



Diese Abdeckung hat die gleiche Anwendung wie die schraubbare Version, aber kann einfach auf die Sammelschienen geschnappt werden, sodass für die Installation kein Werkzeug nötig ist.

Technische Daten:

- Pohlzahl: 3
- Fixierungsschrauben: Kunststoff mit Clips
- Sammelschienenbreite: 100 mm
- Schienenmittenabstand: 100 oder 185 mm
- Abmessungen: 99×572×36 mm

HW-SH/185

Seitliche Abdeckung für Sammelschienenenträger (für 185 mm Sammelschienensysteme)



Diese Abdeckung für den **Sammelschienenenträger** des Typs SH100/185 gibt Berührungsschutz auf der Seite. Mit den seitlichen und Frontabdeckungen kann der gesamte Berührungsschutz der Sammelschienensysteme mit 185 mm Schienenmittenabstand sichergestellt werden.

Technische Daten:

- Pohlzahl: 3
- Fixierungsschrauben: Kunststoff mit Clips
- Schienenmittenabstand: 185 mm
- Abmessungen: 25×442×38 mm

Zubehör für Sicherungs-Lasttrennschalter mit 185 mm Schienenmittenabstand



AL-SL00/42

Adapter für 2 Leisten, Schraubbefestigung

Ausgleichstück zur Höhenanpassung der Baugrösse 00 und 00C, sodass die Schalthebel auf gleicher Ebene wie die Grössen 1-2-3 sind. Das macht die Wartung einfacher und sieht besser aus.

Technische Daten:

- Pohlzahl: 3
- Baugrösse: 00, 00C
- Grösse der Fixierungsschraube: M12
- Sammelschienenbreite: 100 mm
- Schienenmittenabstand: 185 mm
- Abmessungen: 99×450×42 mm



SK-L/SL00/15

Sammelschienenklemme für Geräte mit Grösse 00, 00C

Mit Hilfe dieser Klemmen können die SL00 Geräte schneller auf Sammelschienen montiert werden.

Technische Daten:

- Material: Kupfer, verzinkt
- Baugrösse: 00, 00C
- Grösse der Fixierungsschraube: M12
- Schienenendicke: 5-10 mm



COSMO Sammelschienensystem, 60 mm

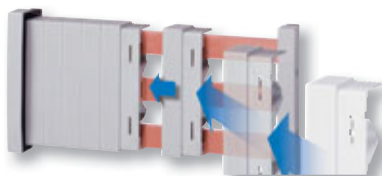

Die Komplettlösung für ein Sammelschienensystem mit 60 mm Schienenmittenabstand.

Spezifikation:

- Hohe Flexibilität • Schnelle Installation
- Weniger Verdrahtung • Einfache Montage
- Universelle Abmessungen



Sammelschienenenträger und Abdeckungen (60 mm System)



TRACON	Typ
SST-60/1	Sammelschienenenträger, 1p
SST-60/3	Sammelschienenenträger, 3p
SST-60/4	Sammelschienenenträger, 4p
A-SST-60/3	Seitliche Abdeckung für 3 P Sammelschiene
A-SST-60/4	Seitliche Abdeckung für 4P Sammelschiene
SAD60/3	Frontabdeckung für 3 P Sammelschiene
SAD60/4	Frontabdeckung für 4 P Sammelschiene

Zweiteiliger Sammelschienenenträger mit integriertem Distanzelement für Sammelschienen mit einer Breite 20-30 mm und einer Dicke 5 und 10 mm. Die Sammelschienenabdeckung deckt das 3 bzw. 4-polige Sammelschienen-System ab und wird aufgeschnappt. Die Abdeckungen können überlappen.

Anschlussmodule (60 mm System)

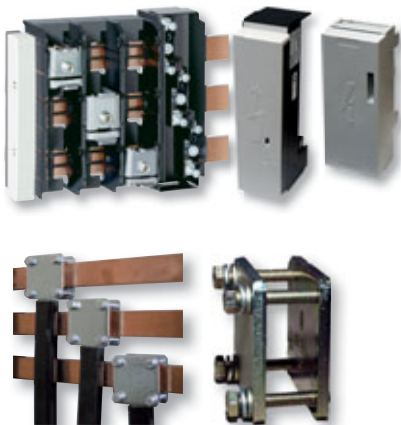

TRACON	Typ, Anschluss (Breite x Dicke)
AM-60/250/3	250A, 1,5mm ² -70mm ²
AM-60/250/3/120-5	250A, 16mm ² -120mm ² , 5 mm Schienenendicke
AM-60/250/3/120-10	250A, 16mm ² -120mm ² , 10 mm Schienenendicke
AM-60/630/3	630A, 70mm ² -300mm ² , 5/10 mm Schienenendicke
PK30/34X10	30 mm Schienenbreite, 34x10 mm Abzweigung
PK40/34X10	40 mm Schienenbreite, 34x10 mm Abzweigung
PK50/34X10	50 mm Schienenbreite, 34x10 mm Abzweigung
PK50/54X10	50 mm Schienenbreite, 54x10 mm Abzweigung
PK60/34X10	60 mm Schienenbreite, 34x10 mm Abzweigung
PK60/54X10	60 mm Schienenbreite, 54x10 mm Abzweigung





Die Anschlussklemmen eignen sich für Einspeisung und Abzweig. Die AM... Klemmen enthalten den Berührungsschutz und sind für Kabel-Abzweige an Sammelschienen. Die PK... Module haben keinen Berührungsschutz, 4 Schrauben sichern den angemessenen Kontakt zwischen Haupt- und Abzweigungsschienen.

Anschlussklemmen





TRACON		
5 mm	10 mm	mm ²
LAK5/1,5-16	LAK10/1,5-16	1,5-16 mm ²
LAK5/1,5-35	LAK10/1,5-35	1,5-35 mm ²
LAK5/1,5-50	LAK10/1,5-50	1,5-50 mm ²
LAK5/16-70	LAK10/16-70	16-70 mm ²
LAK5/16-120	LAK10/16-120	16-120 mm ²
LAK5/16-185	LAK10/16-185	16-185 mm ²

Optionale Klemmen für Sicherungs-Lasttrennschalter

TRACON	 mm ² Cu	 a x b	X 	
S00	6-50	9x5 mm, Cu	2 x M5	00 KETO, SL..
S1	25-150	18x10 mm, Cu	2 x M6	1 KETO
S2	25-240	19x10 mm, Cu	2 x M8	2 KETO
S3	–	21x15 mm, Cu	2 x M8	3 KETO



Prismenklemme

TRACON	 mm ² Cu/Al	X 	
P0070	1x10 - 70	2 x M5	00 KETO, SL..
P0095	1x10 - 95	2 x M5	1 KETO, SL..
P1	1x70 - 150	2 x M6	1 KETO
P2	1x120 - 240	2 x M8	2 KETO
P3	1x120 - 300	2 x M8	3 KETO
P12	2x70 - 95	2 x M6	1 KETO
P22	2x120 - 150	2 x M8	2 KETO
P32	2x120 - 240	2 x M8	3 KETO





P..

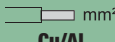

P.2

V-Typ Direktanschlussklemme

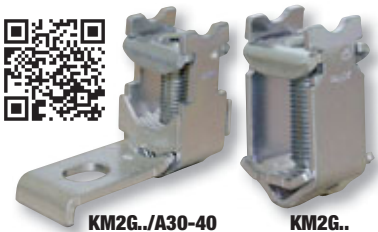

TRACON	 mm ² Cu/Al	 a x b	
KM2G-F	25-240 mm ² Cu/Al	–	1, 2, 3 L/SL..
KM2G	25-300 mm ² Cu/Al	–	1, 2, 3 L/SL..
KM2G-F/A30-40	25-240 mm ² Cu/Al	30-40 mm	1, 2, 3 L/SL..
KM2G/A30-40	25-300 mm ² Cu/Al	30-40 mm	1, 2, 3 L/SL..



KM2G../A30-40

KM2G..

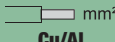
U-Typ Direktanschlussklemme

TRACON	 mm ² Cu/Al	 a x b	
KU00/1/2X/A30-40*	2x10-95 mm ² Cu/Al	30-40 mm	00 L/SL..
KU00	10-95 mm ² Cu/Al	–	00 L/SL..
KU00/2	1x95/2x50 mm ² Cu/AL	–	00 L/SL..



KU00/1/2x A30-40

KU00

* mit Anschlusslasche für die Sammelschienenmontage

Alle Jean Müller Sicherungs-Lasttrennschalter haben Messerkontakte für den sicheren und zuverlässigen Betrieb des elektrischen Netzes. Durch gezielte Lichtbogenführung und minimale Lichtbogendauer wird der Abbrand auf den Kontaktflächen reduziert. Die glatte Oberfläche des Mittelteiles sorgt für optimalen Kontakt um den Verlust niedrig zu halten. Der spezielle Sockel verhindert ein Einbrennen des Gerätes im Kurzschlussfall und ermöglicht eine Kurzschlussfestigkeit bis zu 110kA.



TK Industrielle Handschalter



Piktogramme

I/O



		TK-20	TK-25	TK-32	TK-63	TK-125	TK-160	
I_{th} (A)		20	25	32	63	125	160	
	P_e (kW)	400 V~	AC-23A	7,5	11	15	30	45
AC-2			7,5	11	15	30	45	55
AC-3			5,5	7,5	11	18,5	30	37
AC-4			1,5	3	5,5	7,5	12	15
I_e (A)	400 V~	AC-21A	20	25	32	63	100	150
		AC-22A	20	25	32	63	100	150
		AC-23A	15	22	30	37	90	135
		AC-2	15	22	30	37	90	135
		AC-3	11	15	22	36	75	95
		AC-4	3,5	6,5	11	15	30	55
		AC-15	4	5	6	-	-	-
240 V =	DC-13	1	1,5	4	-	-	-	
($\times 10^3$)		5	5	3	1,5	1,5	1,5	
($\times 10^3$)		3	3	1,2	1	1	1	
		200	150	100	60	30	30	
mm ²		1×2,5	1×4,0	1×6,0	1×25	1×50	1×70	
		2×1,5	2×1,5	2×4,0	2×10	2×25	2×35	
		1×2,5	1×4,0	1×4,0	1×16	1×35	1×50	
		2×1,5	2×1,5	2×2,5	2×6	2×10	2×16	
I_{cw} (1s, A)		200	250	400	600	600	800	
(A)		20	25	32	63	125	160	

Abmessungen und Befestigungsbohrungen

TK..., TKV..., TKB..., TKM..., TKU..., TKI-F

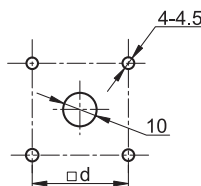
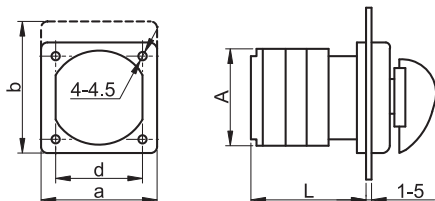

TKF..., TKFL...

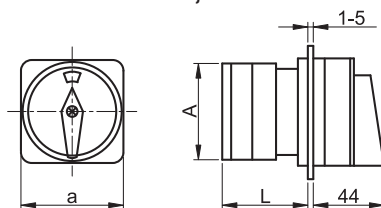

Abmessungen siehe: Sortiment Tabelle! (I/22-I/27.)





















LESEN SIE DIESEN CODE

- Sehen Sie unsere Neuigkeiten an!
- Bleiben Sie auf dem Laufenden.

Unsere Lieferprogramm vergrößert sich schnell und fortlaufend. Bitte verfolgen Sie die Neuheiten auf unserer Webseite. Dieser Katalog enthält unser Lieferprogramm Stand April 2019.

Gehäuse

TRACON		D (mm)	W (mm)	H (mm)	a×b (mm)	C (mm)	d (mm)		IP..
TK/T1+F1/	 + 	68	68	64	48 × 48	25	9,5	2 × MG-20	IP 44
TK/T2+F1/	 + 	68	68	72	48 × 48	25	9,5	2 × MG-20	IP 44
TK/T2+F2/	 + 	68	68	80	48 × 48	32	22	2 × MG-20	IP 44
TK/T3+F3/	 + 	112	112	108	64 × 64	35	11,5	2 × MG-25 2 × MG-32	IP 44
TK/T3+F3S/	 + 	112	112	108	64 × 64	35	11,5	2 × MG-25 2 × MG-32	IP 44
TKTS-01	 + 	110	83	69	48 × 48/ 64 × 64	22	9,5	2 × (2 × MG-20)	IP 65
TKTS-02	 + 	120	113	87	48 × 48/ 64 × 64	25	9,5	2 × (2 × MG-25)	IP 65
TKTS-03	 + 	200	140	109	64 × 64/ 88 × 88	30	11,5	2 × MG-25 2 × MG-32	IP 65

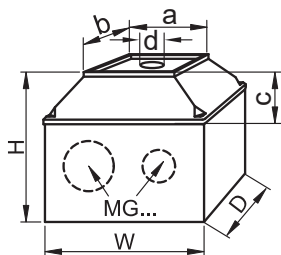

RELEVANT STANDARD
EN 60947-3



TKTS-..

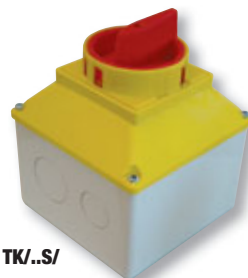

TK/SI/



TK../

Abdichtungs-Set

TRACON	
TKT-65	TK-20..., TK-25..., TKV-20..., TKV-25..., TKB-20..., TKB-25..., TKM-20..., TKM-25..., TKF-20..., TKF-25...
TKT-65/2	TK-32..., TK-63..., TKV-32..., TKV-63..., TKB-32..., TKB-63..., TKM-32..., TKM-63..., TKF-32..., TKF-63...
TKT-65/3	TKFL-..
TKT-65/4	TKFK-..



IP
65

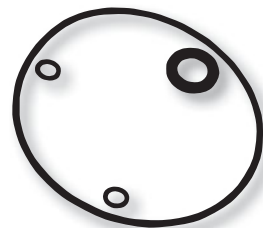

Adapter

TRACON	
TKA	TK-20..., TK-25..., TKV-20..., TKV-25..., TKB-20..., TKB-25..., TKM-20..., TKM-25..., TKF-20..., TKF-25...



 35×7.5



RELEVANT STANDARD
EN 60947-3

TRACON



Algemeine EIN-AUS Schalter

TK-206/2	TK-206/2T	TK-206/2T65	20 A / 2P	TK/T1+F1/
TK-256/2	TK-256/2T	TK-256/2T65	25 A / 2P	TK/T1+F1/
TK-209/2	TK-209/2T	TK-209/2T65	20 A / 2P	TK/T1+F1/
TK-259/2	TK-259/2T	TK-259/2T65	25 A / 2P	TK/T1+F1/
TK-206/3	TK-206/3T	TK-206/3T65	20 A / 3P	TK/T1+F1/
TK-256/3	TK-256/3T	TK-256/3T65	25 A / 3P	TK/T2+F1/
TK-326/3	TK-326/3T	TK-326/3T65	32 A / 3P	TK/T3+F3/
TK-636/3	TK-636/3T	TK-636/3T65	63 A / 3P	TK/T3+F3/
TK-126/3	-	TK-126/3T65	125 A / 3P	TKTS-03
TK-166/3	-	TK-166/3T65	160 A / 3P	TKTS-03
TK-209/3	TK-209/3T	TK-209/3T65	20 A / 3P	TK/T1+F1/
TK-259/3	TK-259/3T	TK-259/3T65	25 A / 3P	TK/T2+F1/
TK-329/3	TK-329/3T	TK-329/3T65	32 A / 3P	TK/T3+F3/
TK-639/3	TK-639/3T	TK-639/3T65	63 A / 3P	TK/T3+F3/
TK-129/3	-	TK-129/3T65	125 A / 3P	TKTS-03
TK-169/3	-	TK-169/3T65	160 A / 3P	TKTS-03
TK-206/4	TK-206/4T	TK-206/4T65	20 A / 4P	TK/T1+F1/
TK-256/4	TK-256/4T	TK-256/4T65	25 A / 4P	TK/T2+F1/
TK-326/4	TK-326/4T	TK-326/4T65	32 A / 4P	TK/T3+F3/
TK-636/4	TK-636/4T	TK-636/4T65	63 A / 4P	TK/T3+F3/
TK-126/4	-	TK-126/4T65	125 A / 4P	TKTS-03
TK-166/4	-	TK-166/4T65	160 A / 4P	TKTS-03
TK-209/4	TK-209/4T	TK-209/4T65	20 A / 4P	TK/T1+F1/
TK-259/4	TK-259/4T	TK-259/4T65	25 A / 4P	TK/T2+F1/
TK-329/4	TK-329/4T	TK-329/4T65	32 A / 4P	TK/T3+F3/
TK-639/4	TK-639/4T	TK-639/4T65	63 A / 4P	TK/T3+F3/
TK-129/4	-	TK-129/4T65	125 A / 4P	TKTS-03
TK-169/4	-	TK-169/4T65	160 A / 4P	TKTS-03

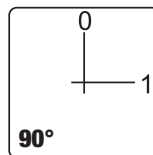
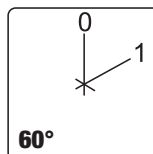
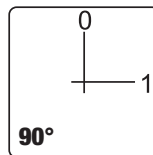
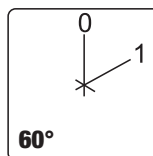
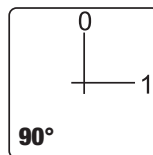
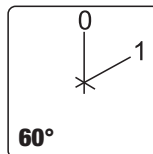

Wahlschalter

TKV-206/3	TKV-206/3T	TKV-206/3T65	20 A / 2×3P	TK/T2+F1/
TKV-256/3	-	TKV-256/3T65	25 A / 2×3P	TKTS-02
TKV-326/3	TKV-326/3T	TKV-326/3T65	32 A / 2×3P	TK/T3+F3/
TKV-636/3	-	TKV-636/3T65	63 A / 2×3P	TKTS-03
TKV-126/3	-	-	125 A / 2×3P	-
TKV-166/3	-	-	160 A / 2×3P	-
TKV-206/4	-	TKV-206/4T65	20 A / 2×4P	TKTS-01
TKV-256/4	-	TKV-256/4T65	25 A / 2×4P	TKTS-02
TKV-326/4	TKV-326/4T	TKV-326/4T65	32 A / 2×4P	TK/T3+F3/
TKV-636/4	-	-	63 A / 2×4P	-
TKV-126/4	-	-	125 A / 2×4P	-
TKV-166/4	-	-	160 A / 2×4P	-

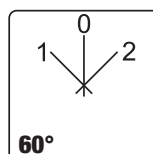
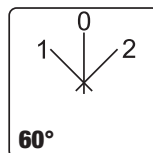



L (mm) **A** (mm) **a** (mm) **b** (mm) **d** (mm)



0° 60°		L	A	a	b	d
1-2	x					
3-4	x					
		28	43,5	48	48	36
		28	43,5	48	48	36



0° 90°		L	A	a	b	d
1-2	x					
3-4	x					
		33	45,3	48	48	36
		33	45,3	48	48	36



0° 60°		L	A	a	b	d
1-2	x	41,2	43	48	48	36
3-4	x	48,6	45,2	48	48	36
5-6	x	54,8	58	64	64	48
		72,2	66	64	64	48
		84	84	88	88	68
		97	88	88	88	68

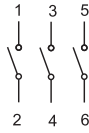

0° 90°		L	A	a	b	d
1-2	x	41,2	43	48	48	36
3-4	x	48,6	45,2	48	48	36
5-6	x	54,8	58	64	64	48
		72,2	66	64	64	48
		84	84	88	88	68
		97	88	88	88	68

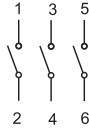

0° 60°		L	A	a	b	d
1-2	x	41,2	43	48	48	36
3-4	x	48,6	45,2	48	48	36
5-6	x	54,8	58	64	64	48
7-8	x	72,2	66	64	64	48
		84	84	88	88	68
		97	88	88	88	68

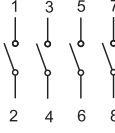

0° 90°		L	A	a	b	d
1-2	x	41,2	43	48	48	36
3-4	x	48,6	45,2	48	48	36
5-6	x	54,8	58	64	64	48
7-8	x	72,2	66	64	64	48
		84	84	88	88	68
		97	88	88	88	68

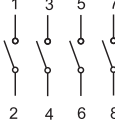

-60° 0° 60°		L	A	a	b	d
1-2	x	50,8	43	48	48	36
3-4		61,4	45,2	48	48	36
5-6	x	67,6	58	64	64	48
7-8		93,7	66	64	64	48
9-10	x	110	84	88	88	68
11-12		130	88	88	88	68

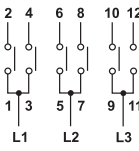

-60° 0° 60°		-60° 0° 60°		L	A	a	b	d
1-2	x	9-10	x	60,4	43	48	48	36
3-4		11-12		74,2	45,2	48	48	36
5-6	x	13-14	x	80,4	58	64	64	48
7-8		15-16		115,2	66	64	64	48
				136	84	88	88	68
				163	88	88	88	68

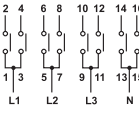

TRACON



Wahlschalter

TKV-209/3	TKV-209/3T	TKV-209/3T65	20 A / 2×3P	TK/T2+F1/
TKV-259/3	-	TKV-259/3T65	25 A / 2×3P	TKTS-02
TKV-329/3	TKV-329/3T	TKV-329/3T65	32 A / 2×3P	TK/T3+F3/
TKV-639/3	-	TKV-639/3T65	63 A / 2×3P	TKTS-03
TKV-129/3	-	-	125 A / 2×3P	-
TKV-169/3	-	-	160 A / 2×3P	-

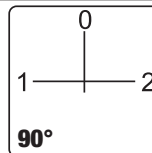

TKV-209/4	-	TKV-209/4T65	20 A / 2×4P	TKTS-01
TKV-259/4	-	TKV-259/4T65	25 A / 2×4P	TKTS-02
TKV-329/4	TKV-329/4T	TKV-329/4T65	32 A / 2×4P	TK/T3+F3/
TKV-639/4	-	-	63 A / 2×4P	-
TKV-129/4	-	-	125 A / 2×4P	-
TKV-169/4	-	-	160 A / 2×4P	-

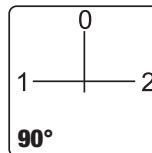

TKB-206/3	TKB-206/3T	TKB-206/3T65	20 A / 2×3P	TK/T2+F1/
TKB-256/3	-	TKB-256/3T65	25 A / 2×3P	TKTS-02
TKB-326/3	TKB-326/3T	TKB-326/3T65	32 A / 2×3P	TK/T3+F3/
TKB-636/3	-	TKB-636/3T65	63 A / 2×3P	TKTS-03
TKB-126/3	-	-	125 A / 2×3P	-
TKB-166/3	-	-	160 A / 2×3P	-

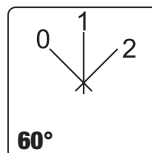

TKB-206/4	-	TKB-206/4T65	20 A / 2×4P	TKTS-01
TKB-256/4	-	TKB-256/4T65	25 A / 2×4P	TKTS-02
TKB-326/4	TKB-326/4T	TKB-326/4T65	32 A / 2×4P	TK/T3+F3/
TKB-636/4	-	-	63 A / 2×4P	-
TKB-126/4	-	-	125 A / 2×4P	-
TKB-166/4	-	-	160 A / 2×4P	-

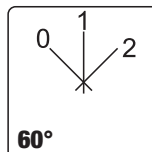

TKB-209/3	TKB-209/3T	TKB-209/3T65	20 A / 2×3P	TK/T2+F1/
TKB-259/3	-	TKB-259/3T65	25 A / 2×3P	TKTS-02
TKB-329/3	TKB-329/3T	TKB-329/3T65	32 A / 2×3P	TK/T3+F3/
TKB-639/3	-	TKB-639/3T65	63 A / 2×3P	TKTS-03
TKB-129/3	-	-	125 A / 2×3P	-
TKB-169/3	-	-	160 A / 2×3P	-

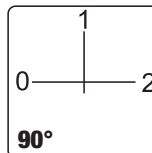

TKB-209/4	-	TKB-209/4T65	20 A / 2×4P	TKTS-01
TKB-259/4	-	TKB-259/4T65	25 A / 2×4P	TKTS-02
TKB-329/4	TKB-329/4T	TKB-329/4T65	32 A / 2×4P	TK/T3+F3/
TKB-639/4	-	-	63 A / 2×4P	-
TKB-129/4	-	-	125 A / 2×4P	-
TKB-169/4	-	-	160 A / 2×4P	-

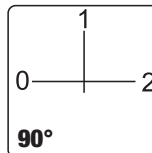

Motorschalter

TKM-20/Q	TKM-20/QT	TKM-20/QT65	5,5 kW	TK/T1+F1/
TKM-25/Q	TKM-25/QT	TKM-25/QT65	7,5 kW	TK/T2+F1/
TKM-32/Q	TKM-32/QT	TKM-32/QT65	11 kW	TK/T3+F3/
TKM-63/Q	TKM-63/QT	TKM-63/QT65	18,5 kW	TK/T3+F3/
TKM-12/Q	-	TKM-12/QT65	30 kW	TKTS-03
TKM-16/Q	-	TKM-16/QT65	37 kW	TKTS-03

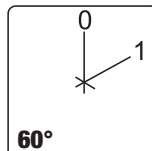

TKM-20/N	TKM-20/NT	TKM-20/NT65	5,5 kW	TK/T2+F1/
TKM-25/N	-	TKM-25/NT65	7,5 kW	TKTS-02
TKM-32/N	TKM-32/NT	TKM-32/NT65	11 kW	TK/T3+F3/
TKM-63/N	-	TKM-63/NT65	18,5 kW	TKTS-03
TKM-12/N	-	-	30 kW	-
TKM-16/N	-	-	37 kW	-

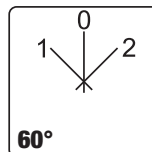
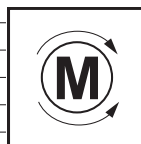

			L	A	a	b	d				
			(mm)	(mm)	(mm)	(mm)	(mm)	1 3 5 7 2 4 6 8			
-90°	0°	90°									
1-2	×		50,8	43	48	48	36	2 4	6 8	10 12	
3-4		×	61,4	45,2	48	48	36	1 3	5 7	9 11	
5-6	×		67,6	58	64	64	48				
7-8		×	93,7	66	64	64	48				
9-10	×		110	84	88	88	68				
11-12		×	130	88	88	88	68				
-90°	0°	90°	-90°	0°	90°						
1-2	×		9-10	×		60,4	43	48	48	36	
3-4		×	11-12		×	74,2	45,2	48	48	36	
5-6	×		13-14	×		80,4	58	64	64	48	
7-8		×	15-16		×	115,2	66	64	64	48	
						136	84	88	88	68	
						163	88	88	88	68	
-60°	0°	60°									
1-2	×		50,8	43	48	48	36	2 4	6 8	10 12	
3-4		×	61,4	45,2	48	48	36	1 3	5 7	9 11	
5-6	×		67,6	58	64	64	48				
7-8		×	93,7	66	64	64	48				
9-10	×		110	84	88	88	68				
11-12		×	130	88	88	88	68				
-60°	0°	60°	-60°	0°	60°						
1-2	×		9-10	×		60,4	43	48	48	36	
3-4		×	11-12		×	74,2	45,2	48	48	36	
5-6	×		13-14	×		80,4	58	64	64	48	
7-8		×	15-16		×	115,2	66	64	64	48	
						136	84	88	88	68	
						163	88	88	88	68	
-90°	0°	90°									
1-2	×		50,8	43	48	48	36	2 4	6 8	10 12	
3-4		×	61,4	45,2	48	48	36	1 3	5 7	9 11	
5-6	×		67,6	58	64	64	48				
7-8		×	93,7	66	64	64	48				
9-10	×		110	84	88	88	68				
11-12		×	130	88	88	88	68				
-90°	0°	90°	-90°	0°	90°						
1-2	×		9-10	×		60,4	43	48	48	36	
3-4		×	11-12		×	74,2	45,2	48	48	36	
5-6	×		13-14	×		80,4	58	64	64	48	
7-8		×	15-16		×	115,2	66	64	64	48	
						136	84	88	88	68	
						163	88	88	88	68	
0	60°										
1-2	×		41,2	43	48	48	36				
3-4	×		48,6	45,2	48	48	36				
5-6	×		54,8	58	64	64	48				
			72,2	66	64	64	48				
			84	84	88	88	68				
			97	88	88	88	68				
-60°	0°	60°									
1-2	×	×	50,8	43	48	48	36				
3-4	×	×	61,4	45,2	48	48	36				
5-6	×		67,6	58	64	64	48				
7-8		×	93,7	66	64	64	48				
9-10		×	111	84	88	88	68				
11-12	×		130	88	88	88	68				



TRACON



Motorschalter

TKM-20/C	-	TKM-20/CT65	Y-Δ 5,5 kW	TKTS-01
TKM-25/C	-	TKM-25/CT65	Y-Δ 7,5 kW	TKTS-02
TKM-32/C	TKM-32/CT	TKM-32/CT65	Y-Δ 11 kW	TK/T3+F3/
TKM-63/C	-	-	Y-Δ 18,5 kW	-
TKM-12/C	-	-	Y-Δ 30 kW	-
TKM-16/C	-	-	Y-Δ 37 kW	-
<hr/>				
TKM-20/D	-	TKM-20/DT65	Dahlander 5,5 kW	TKTS-01
TKM-25/D	-	TKM-25/DT65	Dahlander 7,5 kW	TKTS-02
TKM-32/D	TKM-32/DT	TKM-32/DT65	Dahlander 11 kW	TK/T3+F3/
TKM-63/D	-	-	Dahlander 18,5 kW	-
TKM-12/D	-	-	Dahlander 30 kW	-
TKM-16/D	-	-	Dahlander 37 kW	-

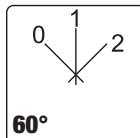
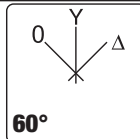

Umschalter für Messzwecke

TKU-F	-	-	Voltmeter-Umschalter für Phasenspannung	-
TKU-V	-	-	Voltmeter-Umschalter für verkettete Spannung	-
TKU-K	-	-	Voltmeter-Umschalter für Phasen- und verkettete Spannung	-
TKI-F	-	-	Amperemeter-Umschalter für Phasenstrom	-

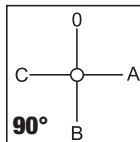
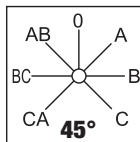
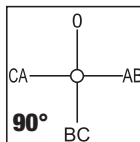
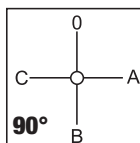

Hauptschalter

TKF-20	TKF-20T	TKF-20T65		20 A / 4P	TK/T3+F3/
TKF-25	TKF-25T	TKF-25T65		25 A / 4P	TK/T3+F3/
TKF-32	TKF-32T	TKF-32T65		32 A / 4P	TK/T3+F3/
TKF-63	TKF-63T	TKF-63T65		63 A / 4P	TK/T3+F3/
TKFK-20	TKFK-20T	TKFK-20T65		20 A / 4P	TK/T2+F2/
TKFK-25	TKFK-25T	TKFK-25T65		25 A / 4P	TK/T2+F2/
TKFK-32	-	-		32 A / 4P	-
TKFK-63	-	-		63 A / 4P	-
TKFL-20	TKFL-20TS	TKFL-20T65S		20 A / 4P	TK/T3+F3S/
TKFL-25	TKFL-25TS	TKFL-25T65S		25 A / 4P	TK/T3+F3S/
TKFL-32	TKFL-32TS	TKFL-32T65S		32 A / 4P	TK/T3+F3S/
TKFL-63	TKFL-63TS	TKFL-63T65S		63 A / 4P	TK/T3+F3S/

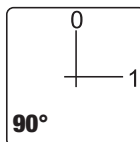
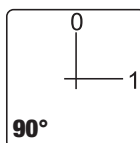
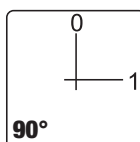

			<table border="1"> <tr><td>1</td><td>0</td><td>2</td></tr> <tr><td>x</td><td>x</td><td>x</td></tr> <tr><td>2</td><td>x</td><td>x</td></tr> <tr><td>3</td><td>x</td><td>x</td></tr> </table>					1	0	2	x	x	x	2	x	x	3	x	x	L	A	a	b	d	
1	0	2																							
x	x	x																							
2	x	x																							
3	x	x																							
-60°	0°	60°	-60°	0°	60°	(mm)	(mm)	(mm)	(mm)	(mm)															
1-2	x	x	9-10	x		57	44	48	48	36															
3-4	x	x	11-12	x		70	46	48	48	36															
5-6	x		13-14		x	78	58	64	64	48															
7-8	x		15-16	x	x	112	66	64	64	48															
						138	84	88	88	68															
						163	88	88	88	68															



TS Lasttrennschalter



Piktogramme

I/O

		TS-20	TS-32	TS-40	TS-63	TS-80	TS-100
I_{th} (A)		20	32	40	63	80	100
P_e (kW), 400 V~	AC-23A	7,5	11	15	22	30	37
	AC-3	5,5	7,5	11	18,5	22	30
(x10 ⁶)		5	5	3	1,5	1,5	1,5
(x10 ⁶)		3	3	1,2	1	1	1
sc/h		200	150	100	60	30	30
mm ²		1x2,5	1x4,0	1x6,0	1x25	1x50	1x70
		2x1,5	2x1,5	2x4,0	2x10	2x25	2x35
		1x2,5	1x4,0	1x4,0	1x16	1x35	1x50
		2x1,5	2x1,5	2x2,5	2x6	2x10	2x16
I_{cw} (1s, A)		180	264	360	516	684	840
		20 A gG	35 A gG	50 A gG	63 A gG	80 A gG	100 A gG

Schaltbild

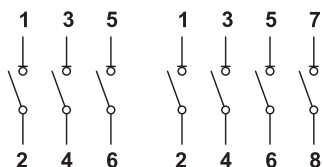

Frontplatte

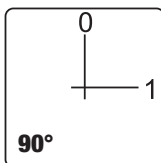

Eigenschaften der TS-Schalter

- geeignet für Ein- und Ausschaltung unter Last, sowie zur Trennung;
- als Motorschalter, Hauptschalter, Trennschalter oder Sicherheits-Schalter einsetzbar;
- hohe mechanische und elektrische Belastbarkeit;
- doppelte Unterbrechung;
- vom Handbetrieb unabhängige Schaltschnelle;
- vor unbeabsichtigter Berührung geschützte spannungsführende Teile;
- Schaltkörper aus selbstverlöschendem Material laut UL94-V0 und hoher Isolationsfestigkeit.



RELEVANT STANDARD
EN 60947-3



Lasttrennschalter

TRACON						L	A	B	a	d	c
IP 42	+	IP44	+	IP65		(mm)	(mm)	(mm)	(mm)	(mm)	(mm)
TS-20/3	TS-20/3T	TS-20/3T65			20 A / 3P	61	54	42	64	48	4.2
TS-32/3	TS-32/3T	TS-32/3T65			32 A / 3P	61	54	42	64	48	4.2
TS-40/3	TS-40/3T	TS-40/3T65			40 A / 3P	67	64	50	64	48	4.2
TS-63/3	TS-63/3T	TS-63/3T65			63 A / 3P	67	64	50	64	48	4.2
TS-80/3	-	TS-80/3T65			80 A / 3P	82	80	70	64	48	4.2
TS-10/3	-	TS-10/3T65			100 A / 3P	82	80	70	88	68	5.2
TS-20/4	TS-20/4T	TS-20/4T65			20 A / 4P	61	54	55.5	64	48	4.2
TS-32/4	TS-32/4T	TS-32/4T65			32 A / 4P	61	54	55.5	64	48	4.2
TS-40/4	TS-40/4T	TS-40/4T65			40 A / 4P	67	64	66	64	48	4.2
TS-63/4	TS-63/4T	TS-63/4T65			63 A / 4P	67	64	66	64	48	4.2
TS-80/4	-	-			80 A / 4P	82	80	92.5	64	48	4.2
TS-10/4	-	-			100 A / 4P	82	80	92.5	88	68	5.2

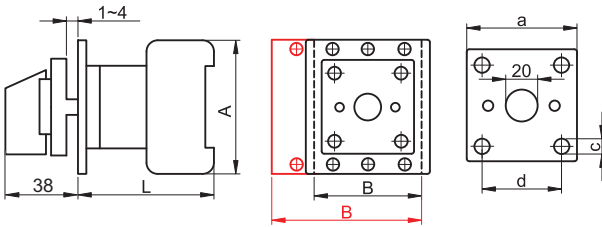

Lasttrennschalter mit Türkupplung

TRACON		L	A	B	a	d	c	x	y
		(mm)	(mm)	(mm)	(mm)	(mm)	(mm)	(mm)	(mm)
TS-20/3K	20 A / 3P	50	54	42	64	48	4.2	22	62
TS-32/3K	32 A / 3P	50	54	42	64	48	4.2	22	62
TS-40/3K	40 A / 3P	61	64	50	64	48	4.2	25	70
TS-63/3K	63 A / 3P	61	64	50	64	48	4.2	25	70
TS-80/3K	80 A / 3P	68	80	70	64	48	4.2	25	90
TS-10/3K	100 A / 3P	68	80	70	88	68	5.2	25	90
TS-20/4K	20 A / 4P	50	54	55.5	64	48	4.2	22	62
TS-32/4K	32 A / 4P	50	54	55.5	64	48	4.2	22	62
TS-40/4K	40 A / 4P	61	64	66	64	48	4.2	25	70
TS-63/4K	63 A / 4P	61	64	66	64	48	4.2	25	70
TS-80/4K	80 A / 4P	68	80	92.5	64	48	4.2	25	90
TS-10/4K	100 A / 4P	68	80	92.5	88	68	5.2	25	90

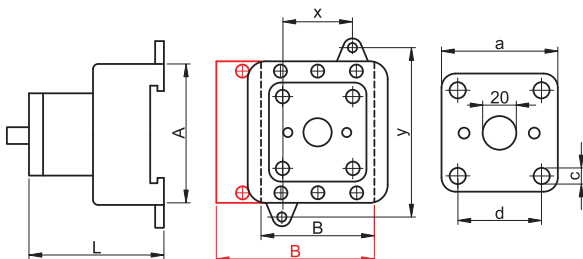

Die Türkupplung sorgt für die Sicherheits-Verriegelung der Tür des Verteilers. Die Tür kann nur in der Schaltposition „0“ des Schalters geöffnet werden.

Wellenlänge: 150 mm

Auf Hutschiene 35 × 7,5 mm (EN 50022) montierbar.

Absperrbare Sicherheits-Hauptschalter

TRACON						L	A	B	a	d	c
IP 42	+	IP44	+	IP65		(mm)	(mm)	(mm)	(mm)	(mm)	(mm)
TSS-20/3	TSS-20/3T	TSS-20/3T65S	20 A / 3P	TK/T3+F3/		61	54	42	64	48	4.2
TSS-32/3	TSS-32/3T	TSS-32/3T65S	32 A / 3P			61	54	42	64	48	4.2
TSS-40/3	TSS-40/3T	TSS-40/3T65S	40 A / 3P	TK/T3+F3S/		67	64	50	64	48	4.2
TSS-63/3	TSS-63/3T	TSS-63/3T65S	63 A / 3P			67	64	50	64	48	4.2
TSS-80/3	-	TSS-80/3T65	80 A / 3P	TKTS-03		82	80	70	64	48	4.2
TSS-10/3	-	TSS-10/3T65	100 A / 3P	TKTS-03		82	80	70	88	68	5.2
TSS-20/4	TSS-20/4T	TSS-20/4T65S	20 A / 4P			61	54	55.5	64	48	4.2
TSS-32/4	TSS-32/4T	TSS-32/4T65S	32 A / 4P	TK/T3+F3S/		61	54	55.5	64	48	4.2
TSS-40/4	TSS-40/4T	TSS-40/4T65S	40 A / 4P			67	64	66	64	48	4.2
TSS-63/4	TSS-63/4T	TSS-63/4T65S	63 A / 4P	TK/T3+F3/		67	64	66	64	48	4.2
TSS-80/4	-	-	80 A / 4P	-		82	80	92.5	64	48	4.2
TSS-10/4	-	-	100 A / 4P	-		82	80	92.5	88	68	5.2

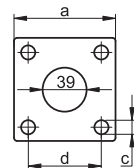
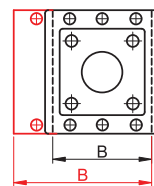
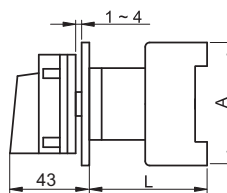

Die Schalter können in ihrer „OFF“ (AUS) Position verriegelt werden.

Absperrbarer Sicherheits-Hauptschalter mit Türkupplung

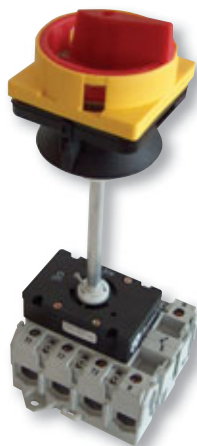

TRACON		L	A	B	a	d	c	x	y
		(mm)	(mm)	(mm)	(mm)	(mm)	(mm)	(mm)	(mm)
TSS-20/3K	20 A / 3P	50	54	42	64	48	4.2	22	62
TSS-32/3K	32 A / 3P	50	54	42	64	48	4.2	22	62
TSS-40/3K	40 A / 3P	61	64	50	64	48	4.2	25	70
TSS-63/3K	63 A / 3P	61	64	50	64	48	4.2	25	70
TSS-80/3K	80 A / 3P	68	80	70	64	48	4.2	25	90
TSS-10/3K	100 A / 3P	68	80	70	88	68	5.2	25	90
TSS-20/4K	20 A / 4P	50	54	55.5	64	48	4.2	22	62
TSS-32/4K	32 A / 4P	50	54	55.5	64	48	4.2	22	62
TSS-40/4K	40 A / 4P	61	64	66	64	48	4.2	25	70
TSS-63/4K	63 A / 4P	61	64	66	64	48	4.2	25	70
TSS-80/4K	80 A / 4P	68	80	92.5	64	48	4.2	25	90
TSS-10/4K	100 A / 4P	68	80	92.5	88	68	5.2	25	90

Die Türkupplung sorgt für die Sicherheits-Verriegelung der Tür des Verteilers. Die Tür kann nur in der Schaltposition „0“ des Schalters geöffnet werden.

Wellenlänge: 150 mm

Auf Hutschiene 35 × 7,5 mm (EN 50022) montierbar.

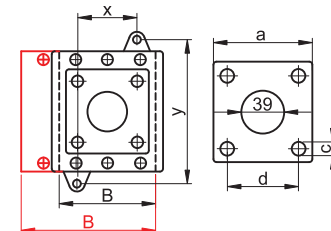
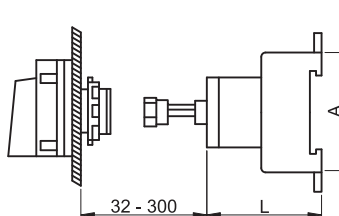

Absperrbarer Hauptschalter für Einbau in Verteiler

TRACON		L (mm)	A (mm)	B (mm)	x (mm)	y (mm)
TSM-20/3	20 A / 3P	50	54	42	22	62
TSM-32/3	32 A / 3P	50	54	42	22	62
TSM-20/4	20 A / 4P	50	54	55.5	22	62
TSM-32/4	32 A / 4P	50	54	55.5	22	62

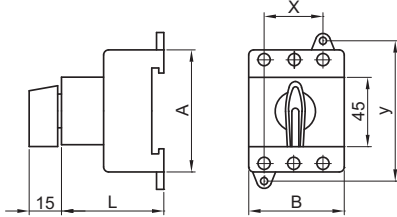
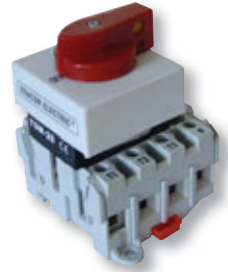

RELEVANT STANDARD
EN 60947-3

Für Standard-Türausschnitt von 45 mm, mit 2 Schrauben an der Rückseite der Frontplatte zu befestigen, alternativ auf Hutschiene von 35 × 7,5 mm montierbar.









EVOMS Reiheneinbau, Absperrbarer Lasttrennschalter

TRACON	Ith (40 °C)
EVOMS16/3	16 A/3P
EVOMS20/3	20 A/3P
EVOMS25/3	25 A/3P
EVOMS40/3	40 A/3P
EVOMS80/3	80 A/3P
EVOMS100/3	100 A/3P
EVOMS125/3	125 A/3P



F/21

Gehäuse

TRACON		W (mm)	H (mm)	D (mm)		IP..
TK/T3+F3/	 + 	112	108	112	2 × MG-25 2 × MG-32	IP 44
TK/T3+F3S/	 + 	112	108	112	2 × MG-25 2 × MG-32	IP 44
TKTS-03	 + 	140	109	200	2 × MG-25 2 × MG-32	IP 44

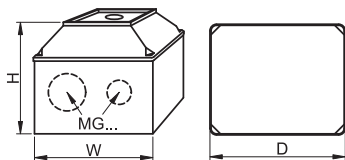

Abdichtungs-Set

TRACON	
TKT-65/2	TS-20/3, TS-32/3, TS-40/3, TS-63/3, TS-20/4, TS-32/4, TS-40/4, TS-63/4
TKT-65/3	TSS-20/3, TSS-32/3, TSS-40/3, TSS-63/3, TSS-20/4, TSS-32/4, TSS-40/4, TSS-63/4

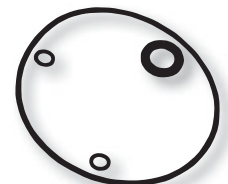

Schütze, Thermische Überlastrelais und Zubehör

230/400 V AC T_a -25...+55°C max. $\pm 30^\circ$ AC 1 AC 3 AC 4 AC 15 AC 6b

Piktogramme I/O

TRACON			
	TR1K..	TR1D..	TR1E..
U_m	AC-1, AC-3, AC-15 24 V AC, 48 V AC, 110 V AC, 230 V AC, 400 V AC	AC-1, AC-3, AC-4 24 V AC, 48 V AC, 110 V AC, 230 V AC, 400 V AC	AC-1, AC-3, AC-4 24 V AC, 48 V AC, 230 V AC, 400 V AC
I_e	6...12 A/AC-3	9...95 A/AC-3	115...620 A/AC-3

Diese Geräte dienen allein oder mit zusätzlichem Schutz zum Schalten von-Motoren und anderen Niederspannungs-Verbrauchern. Mit entsprechenden Hilfsschaltern ergänzt, ermöglichen sie verschiedene Steuerungsaufgaben. Hilfsschalter können sowohl vorne als auch an der Seite montiert werden, ein Zeitbaustein ist an der Vorderseite möglich. Mit ihrer Hilfe lassen sich Melde- oder Verriegelungsaufgaben im Hilfskreis erledigen. Diese Schütze sind mit wechselstrom-betriebenen Spulen in 5 verschiedenen Nennspannungen erhältlich. Die Auswahl der Schütze erfolgt entsprechend der Anwendungskategorie (siehe ANHANG).

Die Schütze sind für den Betrieb mit sinusförmigem Wechselstrom ohne Gleichspannungsanteil bestimmt. Für die Anwendung in elektronischen Steuerungs- oder Regelungskreisen, oder wenn hohe Anteile von harmonischen Wellen zu erwarten sind, muss ein entsprechender Filter verwendet werden.

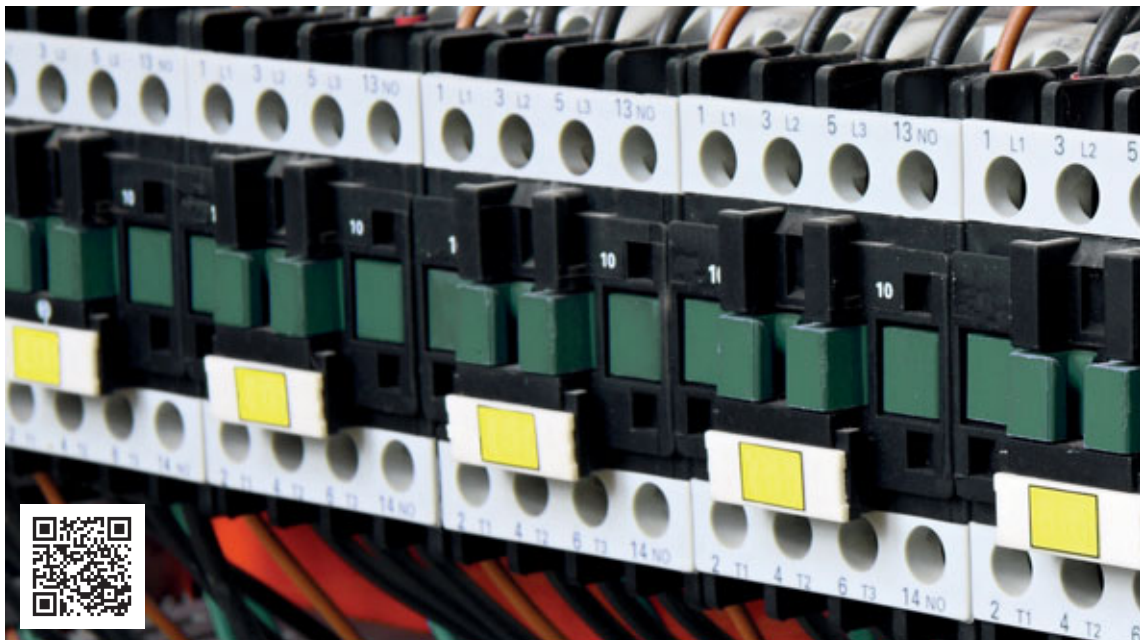

Hilfsschütze

230/400 V AC	690 V	U_e 660 V	I_{th} 20 A	ON-OFF-ON... sc/h x4.800	3×10^6	$\times 10^6$	[mm ²] 1-4	P_{ON} 30 VA	P_{HOLD} 4,5 VA	35x7.5	T_a -25...+55°C	max. $\pm 30^\circ$	IP 20
-----------------	--------------	--------------------------------------	--------------------------------------	--------------------------------	-----------------	---------------	---------------------------	--------------------------------	-----------------------------------	--------	-------------------------------------	---------------------	------------------------

	U _m	TRACON			
		6A/AC-3	9A/AC-3	12A/AC-3	
	24 V~	-	TR1K0904B7	TR1K1204B7	
	48 V~	-	TR1K0904E7	TR1K1204E7	
	110 V~	-	TR1K0904F7	TR1K1204F7	
	230 V~	-	TR1K0904	TR1K1204	
	400 V~	-	TR1K0904V7	TR1K1204V7	
	24 V~	TR1K0610B7	TR1K0910B7	TR1K1210B7	
	48 V~	TR1K0610E7	TR1K0910E7	TR1K1210E7	
	110 V~	TR1K0610F7	TR1K0910F7	TR1K1210F7	
	230 V~	TR1K0610	TR1K0910	TR1K1210	
	400 V~	TR1K0610V7	TR1K0910V7	TR1K1210V7	
	24 V~	TR1K0601B7	TR1K0901B7	TR1K1201B7	
	48 V~	TR1K0601E7	TR1K0901E7	TR1K1201E7	
	110 V~	TR1K0601F7	TR1K0901F7	TR1K1201F7	
	230 V~	TR1K0601	TR1K0901	TR1K1201	
	400 V~	TR1K0601V7	TR1K0901V7	TR1K1201V7	
	24 V~	-	TR1K0908B7	-	
	48 V~	-	TR1K0908E7	-	
	110 V~	-	TR1K0908F7	-	
	230 V~	-	TR1K0908	-	
	400 V~	-	TR1K0908V7	-	
I_e (A)	AC-1	20	20	20	
	AC-3	6	9	12	
	AC15	2	3	4	
P_e (kW)	220/230 V	AC-3	1,5	2,2	3
	380/400 V	AC-3	2,2	4	5,5
	415 V	AC-3	2,2	4	5,5
	500 V, 660/690 V	AC-3	3	4	4
		10 A aM	10 A aM	16 A aM	

Abmessungen und Bohrungen für Befestigung

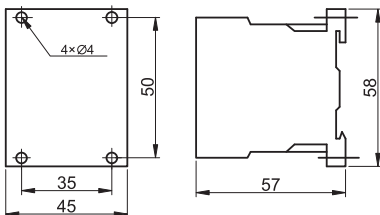

Montage auf
Montageplatte

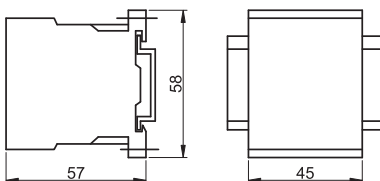

Montage auf
Schiene
(35x7,5 mm)



RELEVANT STANDARD
EN 60947-4-1

RELEVANT STANDARD
EN 60947-1

Schütze des Typs TR1D für allgemeine Anwendungen (9 A ... 32 A)

230/400 V AC	U_i 660 V	U_e 660 V	ON-OFF-ON... sc/h x3.600	3×10^6	$\times 10^6$	AUX (mm ²) 1-4	Ta -25...+55°C	max. £30°	IP 20	Piktogramme	I/O
-----------------	----------------	----------------	--------------------------------	-----------------	---------------	-------------------------------	-------------------	--------------	----------	-------------	-----

		U_m	TRACON				
			9A/AC-3	12A/AC-3	18A/AC-3	25A/AC-3	32A/AC-3
	24 V~		TR1D0910B7	TR1D1210B7	TR1D1810B7	TR1D2510B7	TR1D3210B7
	48 V~		TR1D0910E7	TR1D1210E7	TR1D1810E7	TR1D2510E7	TR1D3210E7
	110 V~		TR1D0910F7	TR1D1210F7	TR1D1810F7	TR1D2510F7	TR1D3210F7
	230 V~		TR1D0910	TR1D1210	TR1D1810	TR1D2510	TR1D3210
	400 V~		TR1D0910V7	TR1D1210V7	TR1D1810V7	TR1D2510V7	TR1D3210V7
	24 V~		TR1D0901B7	TR1D1201B7	TR1D1801B7	TR1D2501B7	TR1D3201B7
	48 V~		TR1D0901E7	TR1D1201E7	TR1D1801E7	TR1D2501E7	TR1D3201E7
	110 V~		TR1D0901F7	TR1D1201F7	TR1D1801F7	TR1D2501F7	TR1D3201F7
	230 V~		TR1D0901	TR1D1201	TR1D1801	TR1D2501	TR1D3201
	400 V~		TR1D0901V7	TR1D1201V7	TR1D1801V7	TR1D2501V7	TR1D3201V7
I_e (A)	AC-1		25	25	32	40	50
	AC-3		9	12	18	25	32
P_e (kW)	AC-4		3,5	5	7,7	8,5	12
	220/230 V	AC-3	2,2	3	4	5,5	7,5
	380/400 V	AC-3	4	5,5	7,5	11	15
	380/400 V	AC-4	4	2,5	3	3,7	4,5
	415 V	AC-3	4	5,5	9	11	15
I _{aux} (A)	500 V, 660/690 V	AC-3	5,5	7,5	10	15	18,5
			10 A aM	16 A aM	20 A aM	32 A aM	40 A aM
	mm ²		4	4	6	10	10
	P_{ON}		60 VA	60 VA	60 VA	90 VA	90 VA
	P_{HOLD}		7 VA	7 VA	7 VA	7,5 VA	7,5 VA

Abmessungen und Bohrungen für Befestigung

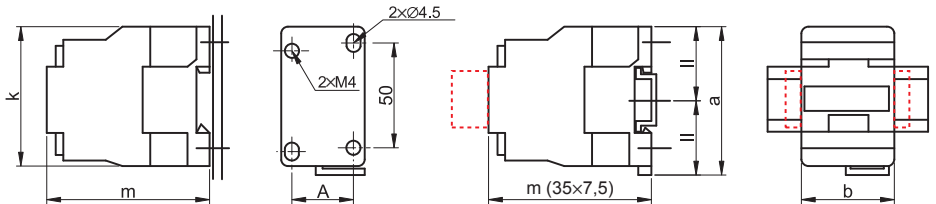

Montage auf Montageplatte

Montage auf Schiene 35 x 7,5 mm



TRACON	TR1D09..	TR1D12..	TR1D18..	TR1D25..	TR1D32..
m (mm)	80	80	85	93	98
A (mm)	35	35	35	44	44
k (mm)	71	71	71	80	80
a (mm)	74	74	74	84	84
b (mm)	46	46	47	57	57
m (35x7,5)	82	82	87	95	100

Schütze des Typs TR1D für allgemeine Anwendungen (40 A ... 95 A)

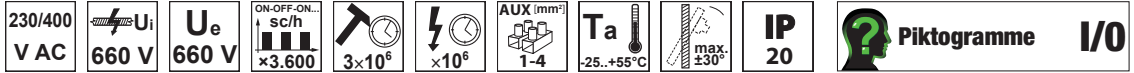

		U _m	TRACON				
			40A/AC-3	50A/AC-3	65A/AC-3	80A/AC-3	95A/AC-3
		24 V~	TR1D4011B7	TR1D5011B7	TR1D6511B7	TR1D8011B7	TR1D9511B7
		48 V~	TR1D4011E7	TR1D5011E7	TR1D6511E7	TR1D8011E7	TR1D9511E7
		110 V~	TR1D4011F7	TR1D5011F7	TR1D6511F7	TR1D8011F7	TR1D9511F7
		230 V~	TR1D4011	TR1D5011	TR1D6511	TR1D8011	TR1D9511
		400 V~	TR1D4011V7	TR1D5011V7	TR1D6511V7	TR1D8011V7	TR1D9511V7
I _e (A)	AC-1	60	80	80	125	125	
	AC-3	40	50	65	80	95	
	AC-4	18,5	24	28	37	44	
	P _e (kW)	220/230 V	AC-3	11	15	18,5	22
380/400 V		AC-3	18,5	22	30	37	45
380/400 V		AC-4	5,5	7,5	9	10	15
415 V		AC-3	22	25	37	45	45
500 V		AC-3	22	30	37	55	55
660/690 V		AC-3	30	33	37	45	45
1000 V	AC-3	-	30	37	45	45	
I _{aux} (A)		5	5	5	5	5	
		50 A aM	50 A aM	63 A aM	80 A aM	100 A aM	
mm ²		25	25	25	50	50	
P _{ON}		200 VA	200 VA	200 VA	200 VA	200 VA	
P _{HOLD}		20 VA	20 VA	20 VA	20 VA	20 VA	

Abmessungen und Bohrungen für Befestigung

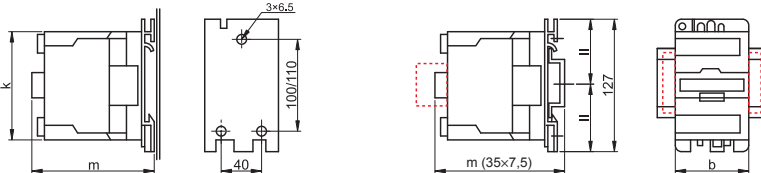

Montage auf Montageplatte

Montage auf Schiene 35 x 7,5 mm



TRACON	TR1D40..	TR1D50..	TR1D65..	TR1D80..	TR1D95..
m (mm)	114	114	114	125	125
k (mm)	107	107	107	123	123
b (mm)	75	75	75	85	85
m (35x7,5)	116	116	116	127	127



I/40



I/41



I/41





I/41



I/43

TEMS Motorstarter Kombinationen im Gehäuse

TRACON	P_e (kW), AC-3*	I_e (A), AC-3*	U_m			
TEMS1-091	1,5	3,5	400 V~	9 A / AC-3	2,5 – 4 A	6 A aM
TEMS1-092	2,2	5	400 V~	9 A / AC-3	4 – 6 A	10 A aM
TEMS1-093	3	6,3	400 V~	9 A / AC-3	5,5 – 8 A	10 A aM
TEMS1-094	4	8,5	400 V~	9 A / AC-3	7 – 10 A	16 A aM
TEMS1-121	5	11,5	400 V~	12 A / AC-3	9 – 13 A	16 A aM
TEMS1-181	7,5	15,5	400 V~	18 A / AC-3	12 – 18 A	20 A aM
TEMS2-251	11	22	400 V~	25 A / AC-3	17 – 25 A	25 A aM
TEMS2-321	15	30	400 V~	32 A / AC-3	23 – 32 A	40 A aM
TEMS3-401	18,5	37	400 V~	40 A / AC-3	30 – 40 A	40 A aM
TEMS3-501	22	44	400 V~	50 A / AC-3	37 – 50 A	63 A aM
TEMS3-651	25	57	400 V~	65 A / AC-3	48 – 65 A	80 A aM
TEMS3-801	37	72,5	400 V~	80 A / AC-3	55 – 70 A	80 A aM
TEMS3-802	37	72,5	400 V~	80 A / AC-3	63 – 80 A	80 A aM
TEMS3-951	45	85	400 V~	95 A / AC-3	80 – 93 A	100 A aM

* Die angeführten Daten gelten für dreiphasige Kurzschlussläufer-Motoren in Dreieck-Schaltung.

Der Starter enthält: eine Schütz, ein thermisches Überlastrelais, zwei Druckknöpfe (EIN – grün, AUS -rot) und ein zweiteiliges Gehäuse aus Kunststoff, oder Stahlblech. Die zulässige Leistung des zu schaltenden Motors hängt von den techn. Daten des Schützes ab. Der zulässige Überlastwert wird am thermischen Überlastrelais eingestellt. Anlassen und Ausschalten des Motors erfolgt mit den EIN/AUS Druckknöpfen. Wird der Motor wegen Überhitzung durch die Schutze ausgeschaltet, muss vor Wiedereinschalten erst die Verriegelung durch Eindrücken des AUS Knopfes gelöst werden. Das Gehäuse bietet mechanischen Schutz. Die Montage auf ebener Fläche ist einfach durch vorgesehene Löcher im Gehäuseunterteil. Kabeleinführung seitlich oder von unten durch ausschlagbare Löcher. Das Gerät wird mit betriebsbereitem Steuerkreis, sowie zusammengebautem Schütz und Überlastrelais geliefert; das heisst, nach Anschluss der Kabel ist der Motorstarter sofort betriebsbereit. Der Starter muss mit Kurzschlusschutz versehen werden!

Technische Daten und Sortiment für den Typ TEMS1

400 V AC  660 V  3×10^6  $\times 10^6$  T_a 0...+55 °C  IP 55

 Piktogramme I/O 



TRACON	TEMS1-091	TEMS1-092	TEMS1-093	TEMS1-094	TEMS1-121	TEMS1-181	
I_e (A), AC-3	400 V 660 V	3,5 2,7	5 3,8	6,3 4,8	8,5 6,6	11,5 8,9	15,5 12
I_{th} (A)	400 V	25	25	25	25	25	32
P_e (kW), AC-3	400 V 660 V	1,5 5,5	2,2 5,5	3 5,5	4 5,5	5,5 7,5	7,5 10
I_{th} (A)	AUX	6	6	6	6	6	6
P_m (VA)	AC-15 DC-13	300 30	300 30	300 30	300 30	300 30	300 30

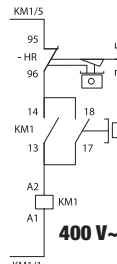
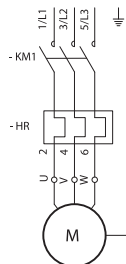
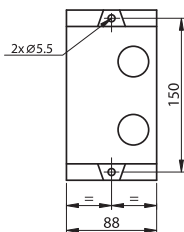
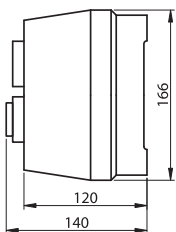

Das Kunststoffgehäuse hat ein Schütz eingebaut mit einem Schliesser als Hilfskontakt zur Anzeige oder Steuerung. Anschluss mit Kabelverschraubungen in vorgesehene Löcher oben (2 St. Pg 13,5) oder unten (1 St. Pg 16 und 1 St. Pg 13,5)

Technische Daten und Sortiment für den Typ TEMS2

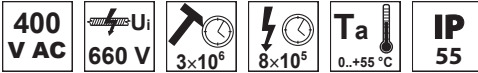

TRACON	TEMS2-251	TEMS2-321	
I_e (A), AC-3	400 V	22	30
	660 V	18	21,3
I_{th} (A)	400 V	40	50
P_e (kW), AC-3	400 V	11	15
	660 V	15	18,5
I_{th} (A)	6	6	6
P_m (VA)	AC-15	300	300
	DC-13	30	30

RELEVANT STANDARD
EN 60529

RELEVANT STANDARD
EN 60695-2-1

RELEVANT STANDARD
EN 60439



Das Kunststoffgehäuse hat ein Schütz eingebaut mit einem Schliesser als Hilfskontakt zur Anzeige oder Steuerung. Anschluss mit Kabelverschraubungen in vorgesehene Löcher oben (2 St. Pg 16) oder unten (1 St. Pg 16 und 1 St. Pg 13,5)

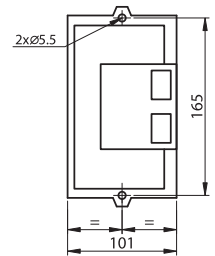
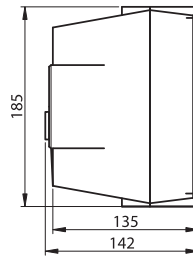
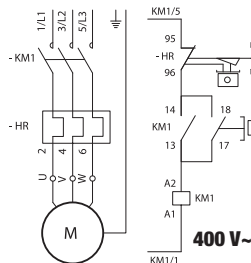

Technische Daten und Sortiment für Typs TEMS3



TRACON	TEMS3-401	TEMS3-501	TEMS3-651	TEMS3-801	TEMS3-951	
I_e (A), AC-3	400 V	37	44	60	72,5	85
	660 V	34,6	39	42	49	49
I_{th} (A)	400 V	60	80	80	125	125
P_e (kW), AC-3	400 V	18,5	22	30	37	45
	660 V	30	33	37	45	55
I_{th} (A)	6	6	6	6	6	6
P_m (VA)	AC-15	300	300	300	300	300
	DC-13	30	30	30	30	30

Das Metallgehäuse hat ein Schütz eingebaut mit einem Schliesser und einem Öffner als Hilfskontakt zur Anzeige oder Steuerung. Anschluss mit Kabelverschraubungen in vorgesehene Löcher oben (1 St. Pg 29, 1 St. Pg 13,5) oder unten (2 St. Pg 29 und 1 St. Pg 13,5)

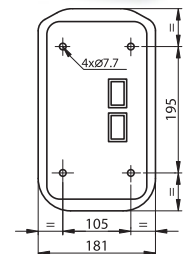
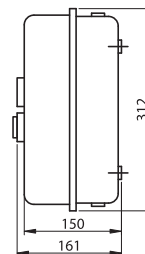
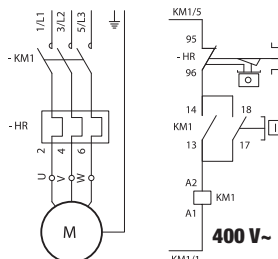

Leistungsschütze für Hochstrom

400 V AC	U_i 660 V	U_e 660 V	AUX (mm²) 1-4	T_a 25...+55°C	max. ±30°	IP 20
-----------------	--------------------------------------	--------------------------------------	------------------------------------	------------------------------------	------------------	------------------------



		U _m	TRACON		
			115A/AC-3	150A/AC-3	170A/AC-3
		24 V~	TR1E115B7	TR1E150B7	TR1E170B7
		48 V~	TR1E115E7	TR1E150E7	TR1E170E7
		230 V~	TR1E115	TR1E150	TR1E170
		400 V~	TR1E115V7	TR1E150V7	TR1E170V7
I_e (A)	AC-1	250	250	250	
	AC-3	115	150	170	
P_e (kW)	AC-4	40	50	60	
	220/230 V	30	40	55	
	380/400 V	55	75	90	
	415 V	59	80	100	
	500 V	75	90	110	
	660/690 V	80	100	110	
	1000 V	65	65	100	
mm ²		95	120	150	
		× 1800	× 1800	× 1800	
/ (× 10 ⁹)		30 / 6	30 / 6	30 / 6	
/ (VA)		550 / 45	550 / 45	805 / 55	



		U _m	TRACON					
			205A/AC-3	245A/AC-3	300A/AC-3	410A/AC-3	475A/AC-3	620A/AC-3
		24 V~	TR1E205B7	TR1E245B7	TR1E300B7	TR1E410B7	TR1E475B7	TR1E620B7
		48 V~	TR1E205E7	TR1E245E7	TR1E300E7	TR1E410E7	TR1E475E7	TR1E620E7
		230 V~	TR1E205	TR1E245	TR1E300	TR1E410	TR1E475	TR1E620
		400 V~	TR1E205V7	TR1E245V7	TR1E300V7	TR1E410V7	TR1E475V7	TR1E620V7
I_e (A)	AC-1	275	315	400	500	700	1000	
	AC-3	205	245	300	410	475	620	
P_e (kW)	AC-4	70	80	100	140	160	210	
	220/230 V	63	75	100	110	147	200	
	380/400 V	110	132	160	200	250	335	
	415 V	110	132	180	220	280	375	
	500 V	129	160	200	257	355	400	
	660/690 V	129	160	220	280	335	450	
	1000 V	100	147	160	185	335	450	
mm ²		185	240	240	2×150	2×240	2×60×5 mm	
		× 1800	× 1800	× 1800	× 900	× 900	× 900	
/ (× 10 ⁹)		30 / 5	30 / 5	30 / 5	10 / 3	10 / 3	10 / 2	
/ (VA)		805 / 55	700 / 8	700 / 8	1150 / 12	1150 / 16	1730 / 20	

Für den Überstromschutz der Schütze des Typs TR1E, s. Seite I/45.

Abmessungen

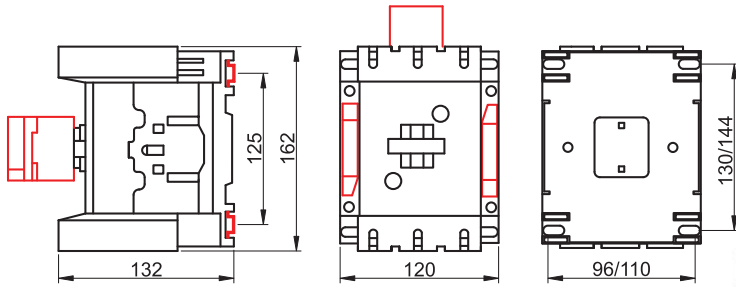

TR1E115 ... TR1E170

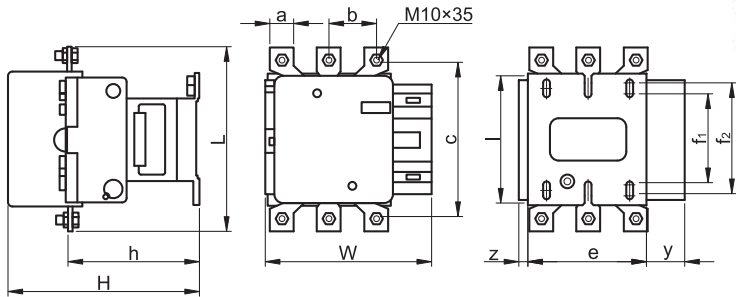

TR1E205 ... TR1E300

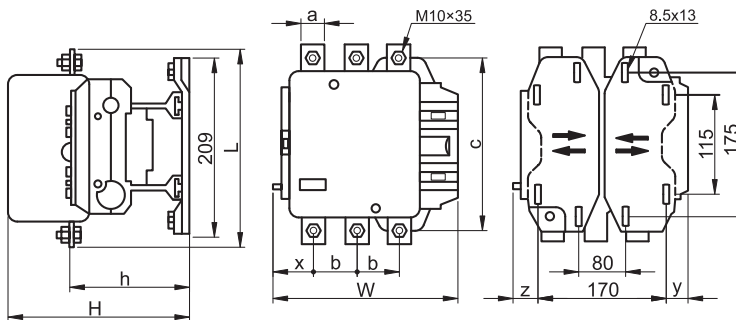

TR1E410, TR1E475

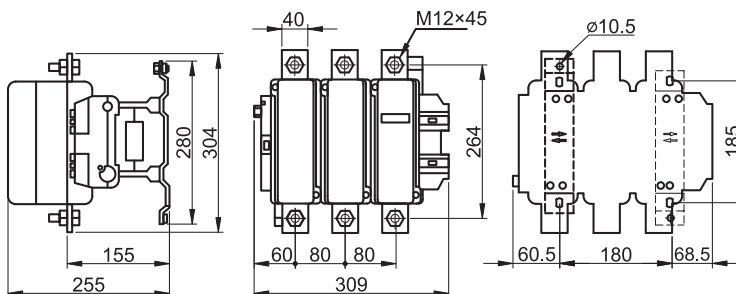

TR1E620



TRACON	W (mm)	H (mm)	L (mm)	a (mm)	b (mm)	c (mm)	l (mm)	e (mm)	x (mm)	f1 (mm)	f2 (mm)	h (mm)	y (mm)	z (mm)
TR1E205	170	181	175	20	40	156	137	80	-	106	120	114	44	15
TR1E245	170	182	196	25	48	172	137	80	-	106	120	113	44	15
TR1E300	215	217	205	25	48	180	145	96	-	110	122	145	38	20,5
TR1E410	215	222	205	25	48	180	-	-	45	-	-	148	23,5	15
TR1E475	235	225	235	30	55	210	-	-	43	-	-	140	44	15

Hilfsschalterblöcke

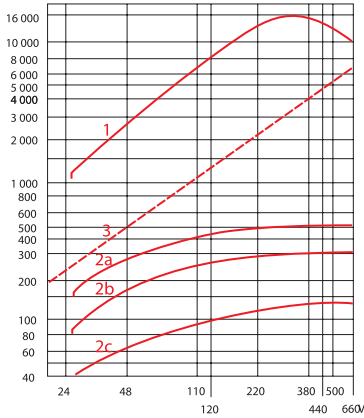

Elektrische Lebensdauer und Schaltleistung (AC15)

	U _e						
	24 V	48 V	110 V 127 V	220 V 230 V	380 V 400 V	440 V	600 V
10 ⁶	150 VA	300 VA	400 VA	480 VA	500 VA	500 VA	500 VA
3×10 ⁶	80 VA	170 VA	250 VA	290 VA	320 VA	320 VA	320 VA
10 ⁷	30 VA	65 VA	90 VA	120 VA	130 VA	130 VA	130 VA

Legende

- 1: Ausschaltvermögen
- 2a: 10⁶ Schaltzyklen
- 2b: 3×10⁶ Schaltzyklen
- 2c: 10⁷ Schaltzyklen
- 3: Erwärmungsgrenze

Hilfsschalterbausteine (Aufbau)

Für TR1K Hilfsschütze

Dimensions: 40 mm width, 32 mm height, 35 mm depth.

TRACON



TR5KN02	2 × NC
TR5KN04	4 × NC
TR5KN11	1 × NO + 1 × NC
TR5KN13	1 × NO + 3 × NC
TR5KN20	2 × NO
TR5KN22	2 × NO + 2 × NC
TR5KN31	3 × NO + 1 × NC
TR5KN40	4 × NO



Für TR1D und TR1E Schütze

Dimensions: 45 mm width, 37 mm height, 6.5 mm depth, 48 mm depth.

TRACON



TR6DN02	2 × NC
TR6DN04	4 × NC
TR6DN11	1 × NO + 1 × NC
TR6DN13	1 × NO + 3 × NC
TR6DN20	2 × NO
TR6DN22	2 × NO + 2 × NC
TR6DN31	3 × NO + 1 × NC
TR6DN40	4 × NO



TR6-DN40
TR5-KN40

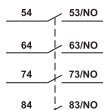

TR6-DN31
TR5-KN31

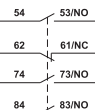

TR6-DN22
TR5-KN22

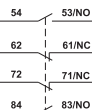

TR6-DN13
TR5-KN13

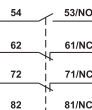

TR6-DN04
TR5-KN04

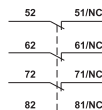

TR6-DN20
TR5-KN20



TR6-DN11
TR5-KN11



TR6-DN02
TR5-KN02

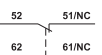

Hilfsschalterbausteine (Seitenanbau) für TR1D09 ... TR1D65 Schütze, TR1E115..170

TRACON



TR8-DN20

2 × NO

TR8-DN11

1 × NC + 1 × NO

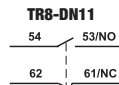
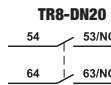
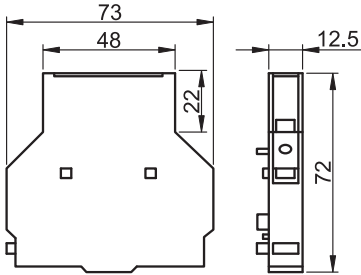

TR8-DN20

TR8-DN11

Zeitbausteine (Aufbau) für TR1D/E Schütze

TRACON



TR7DT2

1 × NC + 1 × NO

0.1-30 s

TR7DR2

1 × NC + 1 × NO

0.1-30 s

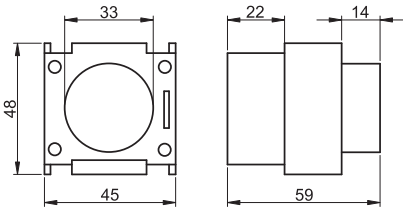

TR7DR2

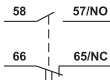

TR7DT2

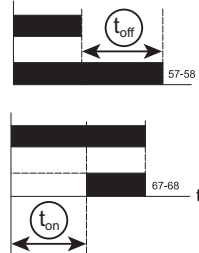

Mechanische Verriegelung

TRACON



TR9-D09978

9-32 A

TR9-D50978

40-95 A

Zwischen 2 Schützen eingebaut, verhindert es die gleichzeitige Einschaltung beider Geräte. Anwendungen: Wendeschaltungen ohne elektrische Verriegelung, Sicherheitsschaltungen mit Hilfsschaltern, Stern-Dreieck-Schaltungen.



TR9-D09978

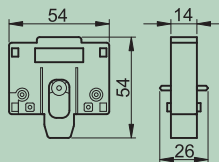

Im Strombereich von 9 - 32 A wird der Abstandshalter in die seitlichen Öffnungen der Schütze eingeschoben.

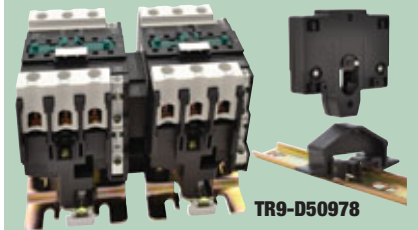

TR9-D50978

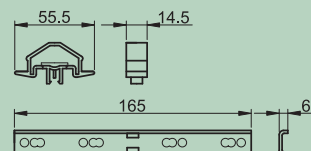

Im Strombereich von 40 - 95 A wird an die Bodenplatten der Magnetschalter eine Hilfsschiene angeschraubt, und der Abstandhalter darauf befestigt.

TR2H Thermische Überlastrelais

Technische Daten (Relais-Kontakte)

U_i 690 V	U_{imp} 6 kV	50/60 Hz 	I_{th} 6 A	I_e 2 A	AC 15	(mm ²) 1-2,5
----------------	-------------------	--------------	-----------------	--------------	-------	-----------------------------

Piktogramme I/O

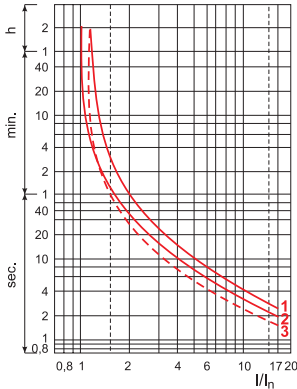

	U_e				
	24 V	48 V	110 V	230 V	400 V
P_e	100 VA	200 VA	400 VA	600 VA	600 VA

Legende

- 1: Drei-Phasen-Lastung, vom kalten Zustand ausgehend
- 2: Zwei-Phasen-Lastung, vom kalten Zustand ausgehend
- 3: Drei-Phasen-Lastung, vom warmen Zustand ausgehend

Thermische Überlastrelais schützen elektrische Motoren und Geräte gegen Überlastung durch Ströme oberhalb des Nennwertes. Die Schutzrelais des Typs TR2HD sind in Gehäusen aus isolierendem Kunststoff untergebracht. Die Anschlussklemmen 1L1, 3L2 und 5L3 der Schutzrelais sind kupferne Stifte und werden an die Klemmen 2T1, 4T2 und 6T3 der Schütze angeschlossen. Die Einstellung der Auslösung des Relais erfolgt vorne am Einstellknopf unter einer durchsichtigen Kappe. Notfalls kann die Einstellung plombiert werden. Auf der Frontplatte des Gerätes befindet sich auch der TEST- Knopf, mit dem die Funktion des Relais überprüft werden kann, sowie der Wahlschalter zwischen Automatik- und Handbetrieb. Mit dem roten STOP - Knopf ausserhalb der Abdeckung kann das Relais ausgeschaltet werden. Thermische Überlastrelais werden mit einem Öffner und einem elektrisch unabhängigen Schliesser geliefert, als auch mit einer Auslöse-Anzeige.

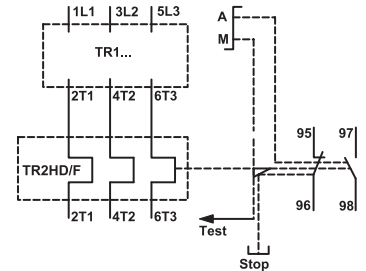

A: Automatische Rücksetzung
M: Manuelle Rücksetzung

Für TR1K Schütze

U_i 690 V	U_{imp} 6 kV	0-400 Hz 	T_a -30...+55°C	IP 20	Class I _r 10A
----------------	-------------------	--------------	----------------------	-------	-----------------------------

Piktogramme I/O

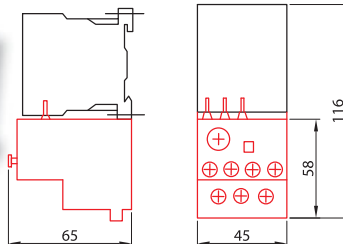

TRACON

I_{th}

mm²



TR2HK0301	0.1 – 0.16 A
TR2HK0302	0.16 – 0.25 A
TR2HK0303	0.25 – 0.4 A
TR2HK0304	0.4 – 0.63 A
TR2HK0305	0.63 – 1 A
TR2HK0306	1 – 1.6 A
TR2HK0307	1.6 – 2.5 A
TR2HK0308	2.5 – 4 A
TR2HK0310	4 – 6 A
TR2HK0312	5.5 – 8 A
TR2HK0314	7 – 10 A
TR2HK0316	9 – 13 A

1.5 – 4



Für TR1D Schütze

TRACON	I_{th}	mm^2
TR2HD1304	0,4 – 0,63 A	2.5 – 10
TR2HD1305	0,63 – 1 A	
TR2HD1306	1 – 1,6 A	
TR2HD1307	1,6 – 2,5 A	
TR2HD1308	2,5 – 4 A	
TR2HD1310	4 – 6 A	
TR2HD1312	5,5 – 8 A	
TR2HD1314	7 – 10 A	
TR2HD1316	9 – 13 A	
TR2HD1321	12 – 18 A	
TR2HD1322	17 – 25 A	
TR2HF2353	23 – 32 A	
TR2HF2355	28 – 36 A	
TR2HD3353	23 – 32 A	
TR2HD3355	30 – 40 A	
TR2HD3357	37 – 50 A	
TR2HD3359	48 – 65 A	
TR2HD3361	55 – 70 A	
TR2HD3363	63 – 80 A	
TR2HD3365	80 – 93 A	



U_i
690 V

U_{imp}
6 kV

0-400 Hz

T_a
-30...+55°C

IP
20

Class Ir
10A



TR2HD1..

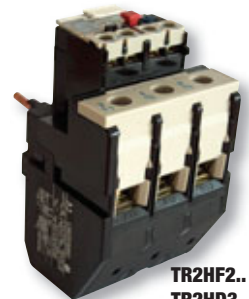

TR2HF2..
TR2HD3..

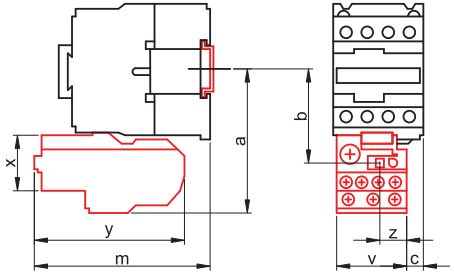

TRACON	a (mm)	b (mm)	c (mm)	m (mm)	x (mm)	y (mm)	v (mm)	z (mm)
TR1D09...D18	81	50	0	98	47	92	44	17
TR1D25	86	55	10.7	108	47	92	44	17
TR1D32	86	55	8.1	109	47	92	44	17
TR1D40...D65	111	72.4	4.5	119	54	109	70	30
TR1D80...D95	115.5	76.9	9.5	124	54	109	70	30

Adapter für thermische Relais

TRACON	L	H	W
TR2AD1	TR2HD13..	46×78×86 mm	
TR2AD3	TR2HF23.., TR2HD33..	73×103×120 mm	

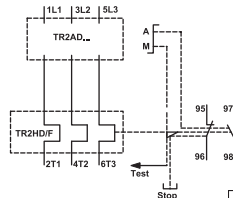

A: Automatische Rücksetzung
M: Manuelle Rücksetzung



RELEVANT STANDARD
EN 60947-1

RELEVANT STANDARD
EN 60947-4-1

EVOHK Installations Schütze







F/23





Anpassungstabellen für Bestellung von Schützen und thermischen Überlastrelais

Diese Tabellen helfen, das richtige Schütz und thermische Überlastrelais für Motoren auszuwählen. Die angegebenen Leistungs- und Stromwerte gelten für den Betrieb eines 3-Phasen- Motors in Dreieck-Schaltung, Kategorie der Anwendung: AC3.

Beispiele für Bestellung von TR1K Typ Schütze und TR2HK Thermische Überlastrelais

Pe (kW)	Ie (A)			I _{th}		
						
					aM	gG (gL)
–	0,1	TR1K06	TR2HK0301	0,1 – 0,16	1	2
0,06	0,16	TR1K06	TR2HK0302	0,16 – 0,25	1	2
0,08	0,25	TR1K06	TR2HK0303	0,25 – 0,4	1	2
0,1	0,4	TR1K06	TR2HK0304	0,4 – 0,63	2	4
0,3	1,0	TR1K06	TR2HK0305	0,63 – 1	2	4
0,4	1,0	TR1K06	TR2HK0306	1 – 1,6	2	4
0,8	2,0	TR1K06	TR2HK0307	1,6 – 2,5	4	6
1,1	2,6	TR1K06	TR2HK0308	2,5 – 4	6	10
1,5	3,5	TR1K06	TR2HK0308	2,5 – 4	6	10
2,2	5,0	TR1K06	TR2HK0310	4 – 6	10	16
3,0	6,3	TR1K06	TR2HK0312	5,5 – 8	10	16
4,0	8,5	TR1K09	TR2HK0314	7 – 10	10	20
5,0	11	TR1K12	TR2HK0316	9 – 13	16	25

Beispiele für Bestellung von TR1D Typ Schütze und TR2HD Thermische Überlastrelais

Pe (kW)	Ie (A)			I _{th}		
						
					aM	gG (gL)
0,1	0,4	TR1D09	TR2HD1304	0,4-0,63	2	4
0,3	1,0	TR1D09	TR2HD1305	0,63-1	2	4
0,4	1,0	TR1D09	TR2HD1306	1-1,6	2	4
0,8	2,0	TR1D09	TR2HD1307	1,6-2,5	4	6
1,1	2,6	TR1D09	TR2HD1308	2,5-4,0	6	10
1,5	3,5	TR1D09	TR2HD1308	2,5-4,0	6	10
2,2	5,0	TR1D09	TR2HD1310	4,0-6,0	10	16
3,0	6,3	TR1D09	TR2HD1312	5,5-8	10	16
4,0	8,5	TR1D09	TR2HD1314	7,0-10,0	10	20
5,0	11,0	TR1D12	TR2HD1316	9-13,0	16	25
7,5	15,5	TR1D18	TR2HD1321	12,0-18,0	20	35
9,0	18,0	TR1D18	TR2HD1321	12,0-18,0	25	35
11,0	22,0	TR1D25	TR2HD1322	17,0-25,0	25	50
15,0	30,0	TR1D40	TR2HD3353	23,0-32,0	40	63
18,0	40,0	TR1D40	TR2HD3355	30-40,0	50	63
22,0	44,0	TR1D50	TR2HD3357	37,0-50,0	63	80
25,0	57,0	TR1D65	TR2HD3359	48-65,0	80	100
30,0	60,0	TR1D65	TR2HD3361	55,0-70,0	80	100
37,0	72,0	TR1D80	TR2HD3363	63,0-80,0	80	125
45,0	93,0	TR1D95	TR2HD3365	80-93,0	100	125

Motorstarter Kombination

Mit Schützen des Typs **TR1D..** in Kombination mit Hilfsschalterblöcken, Zeitbausteinen und thermischen Relais, können verschiedene Starterkombinationen konfiguriert werden, z.B. Stern-Dreieck Motorstarter.

Für einen Stern-Dreieck Motorstarter sind 3 Schütze, 2 Hilfskontakte, 1 Zeitbaustein und 1 thermisches Relais erforderlich. Im ANHANG des Kataloges gibt es Hilfestellung für die Anordnung der Geräte, sowie Schaltpläne.

Überstromschutz für mit Leistungsschützen gesteuerte elektrische Geräte

Der Überstromschutz für Elektrogeräte, die mit Leistungsschützen gesteuert werden, erfolgt normalerweise direkt mit Überlastschutz-Kombinationen. Ein Überstrom-Schutzrelais wird in jede Phase eingebaut, einstellbar im Bereich von 0 - 5 A. Die Sekundär-Spulen der Stromwandler werden mit den Eingängen des Schutz-Relais verbunden. Wenn die passenden Hilfskontakte der Überstrom-Schutzrelais in alle 3 Phasen in Reihe geschaltet sind und irgendein Phasenstromwert die Stromschwelle übersteigt, zieht das Schutzrelais in der fehlerhaften Phase an und unterbricht den Stromkreis des Leistungsschützes.

Bemerkung: diese Lösung folgt nicht der Standard-Kennlinie des Motorschutzes.

Kontaktausführung

L,N	Energieversorgung
k,l	Kontakte für Stromwandler
1	NO Schliesser
2	CO Wechsler
3	NC Öffner

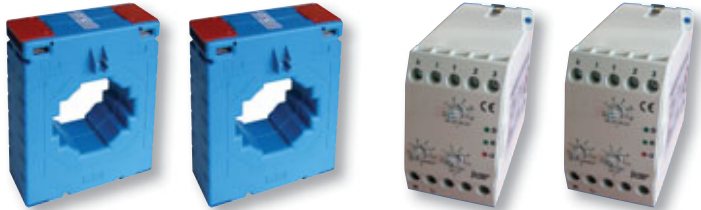

Elemente der Überstromschutz-Kombination

TRACON	Benennung	Stückzahl	Seite
TFKV-AKA05	Überstromauslöser Schutzrelais	3 St (1 St pro Phase)	J/21
AVBS, AV...-SH	Stromwandler mit 5A sekundärem Strom	3 St (1 St pro Phase)	L/26

Bemerkung:

- Das Schutzgerät erlaubt den Anlaufstrom während der einstellbaren Zeit von 0,5 - 8 s
- Liegt die gemessene Stromstärke ausserhalb des eingestellten Bereiches, schaltet der Relais-Ausgang nach Ablauf der eingestellten Zeit um.
- Wenn der Sekundärstrom des Wandlers innerhalb der eingestellten Zeit (0,5 - 15 s) auf den eingestellten Wert sinkt, erfolgt keine Umschaltung des Relais-Ausganges.

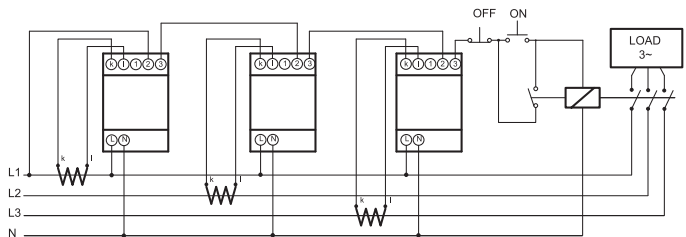

- Es ist zweckmässig, die Verzögerungszeiten der Überstromrelais in allen drei Phasen auf den gleichen Wert einzustellen.

n	TRACON	I _{th} min	I _{th} max	I _{set} (A)					
				0,5	1	2	3	4	5
-	-	0,5 A	5 A	0,5 A	1 A	2 A	3 A	4 A	5 A
100/5A	TR1E115	10 A	100 A	10 A	20	40	60	80	100 A
120/5A	TR1E115	12 A	120 A	12 A	24	48	72	96	120 A
125/5A	TR1E150	12,5 A	125 A	12,5 A	25	50	75	100	125 A
150/5A	TR1E170	15 A	150 A	15 A	30	60	90	120	150 A
200/5A	TR1E205	20 A	200 A	20 A	40	80	120	160	200 A
250/5A	TR1E245	25 A	250 A	25 A	50	100	150	200	250 A
300/5A	TR1E300	30 A	300 A	30 A	60	120	180	240	300 A
400/5A	TR1E410	40 A	400 A	40 A	80	160	240	320	400 A
500/5A	TR1E475	50 A	500 A	50 A	100	200	300	400	500 A
600/5A	TR1E620	60 A	600 A	60 A	120	240	360	480	600 A
750/5A	-	75 A	750 A	75 A	150	300	450	600	750 A
800/5A	-	80 A	800 A	80 A	160	320	480	640	800 A
1000/5A	-	100 A	1000 A	100 A	200	400	600	800	1000 A
1500/5A	-	150 A	1500 A	150 A	300	600	900	1200	1500 A
2000/5A	-	200 A	2000 A	200 A	400	800	1200	1600	2000 A
2500/5A	-	250 A	2500 A	250 A	500	1000	1500	2000	2500 A
3000/5A	-	300 A	3000 A	300 A	600	1200	1800	2400	3000 A
4000/5A	-	400 A	4000 A	400 A	800	1600	2400	3200	4000 A
5000/5A	-	500 A	5000 A	500 A	1000	2000	3000	4000	5000 A

Handbetätigte Motorschutzschalter

400 V AC	U_i 690 V	U_{imp} 6 kV	50/60 Hz	$\times 10^5$	$\times 10^5$	ON-OFF-ON... sc/h $\times 25$	AC 3	IP 20	T_a -25...+55°C	(mm ²) 2x1-2x6	Class Ir 10A	P_m 2,5 VA AC
-----------------	-------------------------------	--------------------------------	----------	---------------	---------------	-------------------------------------	-------------	--------------	-------------------------------------	-------------------------------	-------------------------------	-----------------------------------

TRACON	I _e	P _e	I _m	gG (A)	
				aM (A)	gG (A)
TGV2-01	0,1 - 0,16 A	-	1,5 A	-	1
TGV2-02	0,16 - 0,25 A	0,06 kW	2,4 A	-	1
TGV2-03	0,25 - 0,4 A	0,09 kW	5 A	1	2
TGV2-04	0,4 - 0,63 A	0,18 kW	8 A	1	2
TGV2-05	0,63 - 1 A	0,37 kW	13 A	1	2
TGV2-06	1 - 1,6 A	0,55 kW	22,5 A	2	4
TGV2-07	1,6 - 2,5 A	0,75 kW	33,5 A	4	6
TGV2-08	2,5 - 4 A	1,5 kW	51 A	6	10
TGV2-10	4 - 6,3 A	2,2 kW	78 A	10	16
TGV2-14	6 - 10 A	4 kW	138 A	10	20
TGV2-16	9 - 14 A	5,5 kW	170 A	16	25
TGV2-20	13 - 18 A	7,5 kW	223 A	20	32
TGV2-21	17 - 23 A	11 kW	327 A	25	50
TGV2-22	20 - 25 A	11 kW	327 A	25	50
TGV2-32	24 - 32 A	15 kW	416 A	40	63

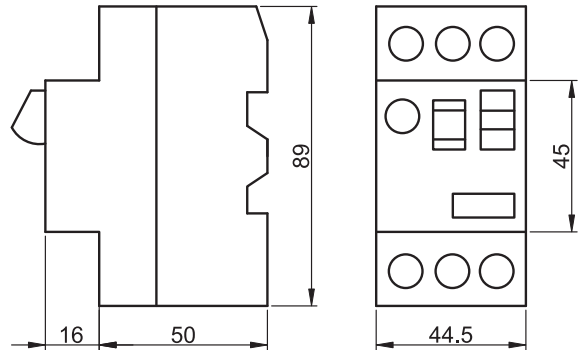

RELEVANT STANDARD
EN 60947-4-1

RELEVANT STANDARD
EN 60947-1



Dieses Gerät dient vor allem zum Schalten und Schützen von Motoren und anderer dreiphasiger Last. Die Abschaltung erfolgt entweder durch thermischen oder elektromagnetischen Auslöser.

Das Ein- und Ausschalten erfolgt von Hand. Der Nennstrom des zu schützenden Motors wird innerhalb des Einstellbereiches mit Hand stufenlos eingestellt. TGV-2 Motorschutzschalter - ergänzt mit verschiedenem Zubehör (Auslöse-Anzeige, Hilfsschaltern Kurzschlussauslösern, Gehäusen) - sind einsetzbar zur Fernbedienung in verschiedenen Steuerungen.

Auslösecharakteristik

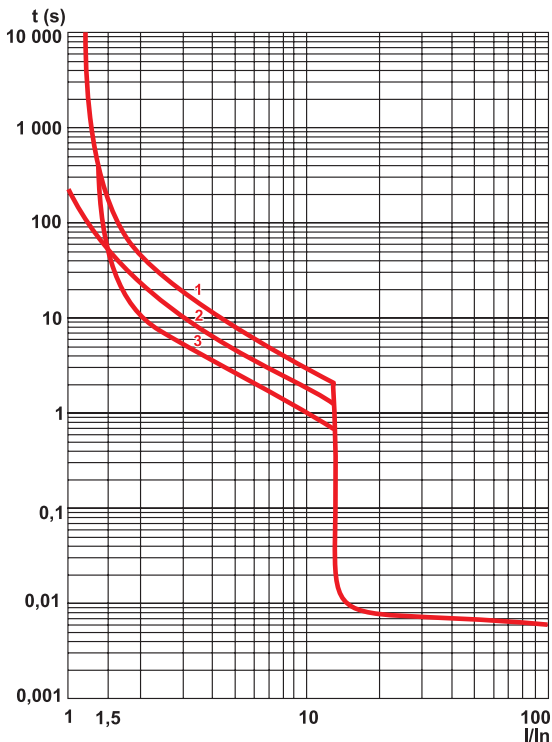

- Legende**
- 1:** Drei-Phasen-Belastung, vom kalten Zustand ausgehend
 - 2:** Zwei-Phasen-Belastung, vom kalten Zustand ausgehend
 - 3:** Drei-Phasen-Belastung, vom warmen Zustand ausgehend

Strombegrenzcharakteristik

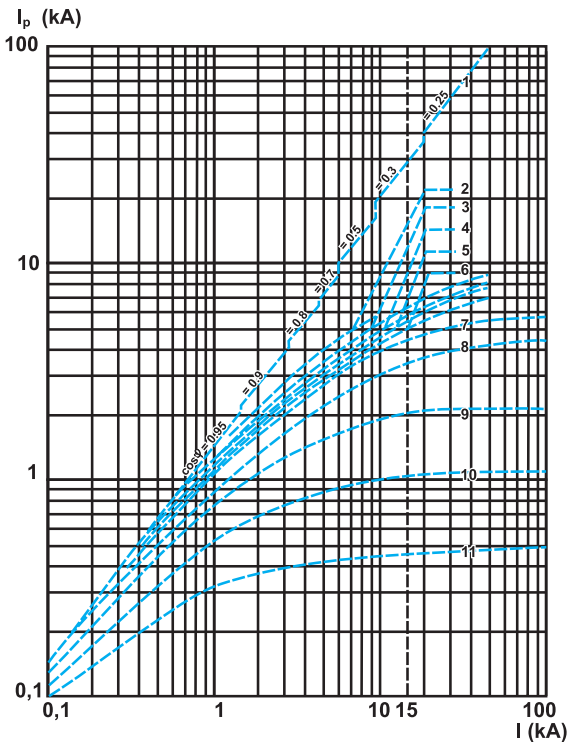

- Legende**
- 1:** I_{pmax}
 - 2:** 24-32 A
 - 3:** 20-25 A
 - 4:** 17-23 A
 - 5:** 13-18 A
 - 6:** 9-14 A
 - 7:** 6-10 A
 - 8:** 4-6.3 A
 - 9:** 2.5-4 A
 - 10:** 1.6-2.5 A
 - 11:** 1-1.6 A

Allgemeine technische Daten

U_i 690 V	10 A gG	50/60 Hz	$\times 10^5$	P_m 5 VA	[mm ²] 0,75-2,5	P_m 5 VA AC
-----------------------	----------------	-----------------	---------------	-------------------------------------	---------------------------------------	--

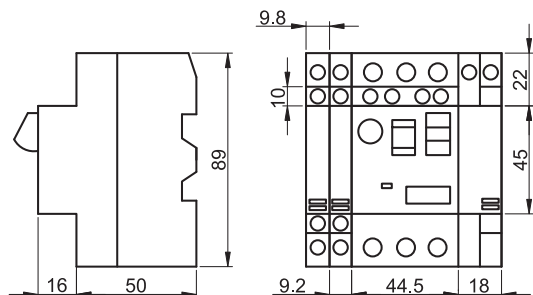

Motorschutzschalter - ergänzt mit verschiedenem Zubehör (Auslöse-Anzeige, Hilfsschaltern, Kurzschlussauslösern, Gehäusen) - sind einsetzbar zur Fernbedienung in verschiedenen Steuerungen. Für unabhängige Anwendungen kann der Motorschutzschalter im Gehäuse verwendet werden. Die Schutzart erhöht sich auf IP41 oder IP55.

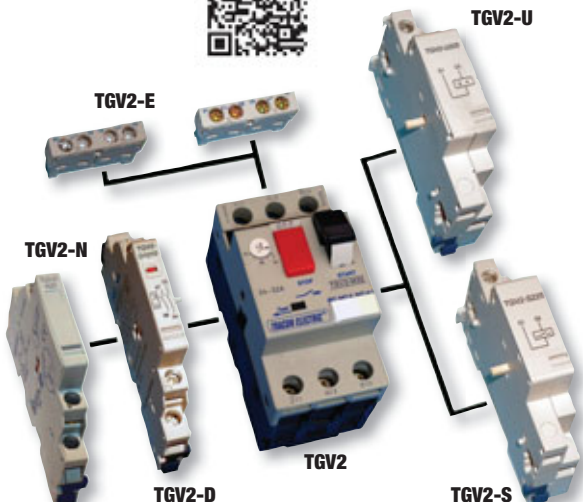

Hilfskontakte (Aufbau)

U_e (V)		24	48	60	230
I_e (A)	AC15	2	1,25	-	0,5
	DC13	1	0,3	0,15	-
I_{th} (A)		2,5 A			

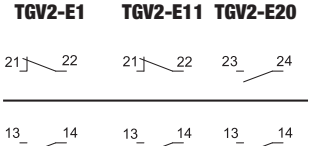
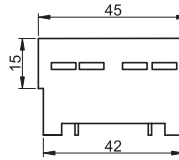

* Die Schliesser oder Öffner Funktion hängt davon ab, wie der Hilfsschalter angebracht ist.

Hilfskontaktblöcke informieren über EIN- / AUS- Status der Motorschutzschalter, ferner sind sie auch zur Lösung von Steuerungs- und Meldeaufgaben einsetzbar. Die Hilfskontakte können nach Entfernung des Deckels an die Frontplatte der Schütze angeschlossen werden.

Hilfskontakte (Seitlicher Anbau)



U_e (V)		24	48	110	230	400
I_e (A)	AC15	-	6	4,5	3	2
	DC13	6	5	1,3	0,5	-
I_{th} (A)		6 A				

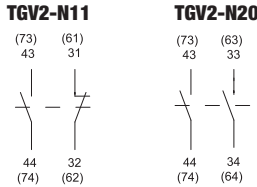

Hilfskontaktblöcke informieren über EIN- / AUS- Status der Motorschutzschalter, ferner sind sie auch zur Lösung von Steuerungs- und Meldeaufgaben einsetzbar.

TRACON	
TGV2-N11	1×NC + 1×NO
TGV2-N20	2×NO

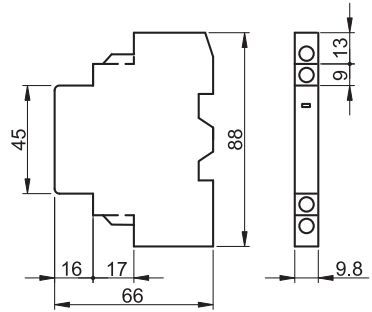

Fehlersignal Kurzschlussauslöser



U_e (V)		24	48	60
I_e (A)	AC15	1,5	1	-
	DC13	1	0,3	0,15
I_{th} (A)		2,5 A		

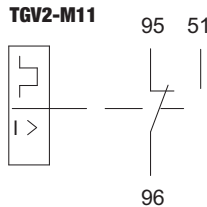

Tritt ein Motorfehler auf, informieren Fehlersignale über die Art der Störung (Kurzschluss, Überlast, usw.).

TRACON	
TGV2-M11	1×CO

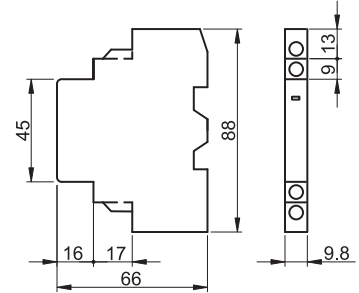

Fehlersignal Überlastauslöser

TRACON	AUX	
TGV2-D1010	1×NO	1×NO
TGV2-D1001	1×NC	1×NO
TGV2-D0110	1×NO	1×NC
TGV2-D0101	1×NC	1×NC

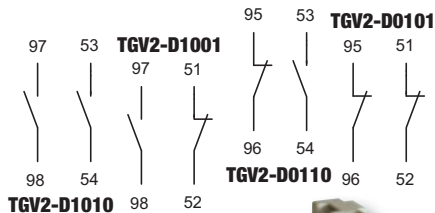

U _e (V)	AUX							
	24	48	60	24	48	230		400
I _e (A)	AC15	1.5	1	-	-	6	3	2
	DC13	1	0.3	0.15	6	5	0.5	-
I _{th} (A)	2,5A			6A				

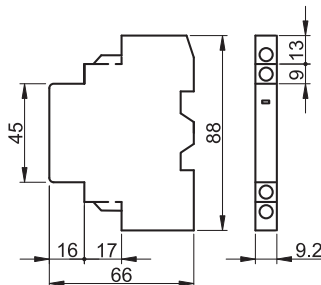

Unterspannungsauslöser

TRACON	U _m	P _m
TGV2-U225	220-240 V AC	max. 5 VA
TGV2-U385	400-415 V AC	max. 5 VA

Der Unterspannungsauslöser schaltet die Schütze aus und blockiert die Einschaltung, wenn der Wert der Betriebsspannung unter 35 – 70% des Nennwertes fällt.

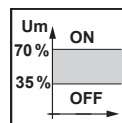
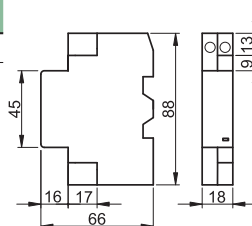
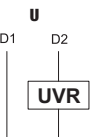

Arbeitsstromauslöserblock

TRACON	U _m	P _m
TGV2-S225	220-240 V AC	max. 5 VA
TGV2-S385	400-415 V AC	max. 5 VA

Der Arbeitsstromauslöser arbeitet bei 70 - 110% der Nenn-Betriebsspannung und schaltet die Schütze aus (und erfüllt damit seine Fernbedienungs-Aufgabe).

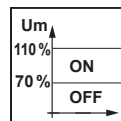
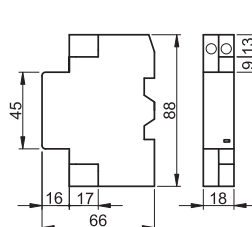
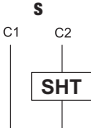

Gehäuse

TRACON	IP..
TGV2-T1	IP 41
TGV2-T2	IP 55

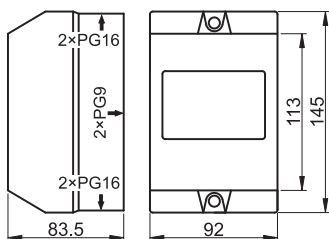

TGV2-T1

TGV2-T2