



































## Pictograms of the table heads

<b>U<sub>m</sub></b> Nominal control voltage	<b>P<sub>n</sub></b> Rated power	 Rated power	 Notes, additions
 Primary voltage	 Secondary voltage	 Secondary current	 Secondary power values
 Two position	 Three position	 Key takeout position (left)	 Key takeout position (left and right)
 Key takeout position (middle)	 Key takeout position	 Releasing: by turning	 Releasing: with key
 Electric data of contacts	 Light (LED) units	 Dimension	 Tape of socket
 Tighten torque	 Thread	 Quick-connecting terminals	 Cableglands
 Basis type	 With enclosure IP 44	<b>IP..</b> Protection degree	 Colour
 Weight			

## Pictograms of the technical data

<b>230/400 V AC</b> Rated voltage (V)	<b>U<sub>m</sub></b> max. 400 V Nominal control voltage	 <b>U<sub>i</sub></b> 660 V Rated insulation voltage	<b>U<sub>imp</sub></b> 6 kV Rated impulse withstand voltage
<b>I<sub>e</sub></b> (AC 1, 230 V) 15 A Nominal operational current	<b>50/60 Hz</b> Rated frequency	 Suggested backup fuse	<b>[mm<sup>2</sup>]</b> 0,5-2,5 Connectable cable
 The operator heads can be turned in 90° steps!	 The operator heads can be turned in 90° steps, the arm in 180° steps!	<b>F<sub>on</sub></b> max. 20 N Switching on force	<b>F<sub>off</sub></b> max. 15 N Switching off force
 Mechanical life	<b>E</b> +120 °C Heat-proof category	 Protection class: I.	<b>ON-OFF-ON...</b> sc/h x3.600 Switching frequency (C-O cycles/hour)
<b>IP 42</b> Protection degree (installed, from the front side)	<b>IP 20</b> Protection of terminals (basic)	<b>IP 55</b> Protection degree	 Vibration resistance
 Relativ humidity	<b>T<sub>a</sub></b> -25..+55°C Ambient temperature		

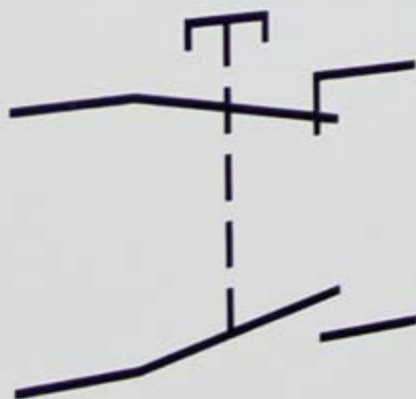



LS15 limit switches **2**



LS7 limit switches **5**



LSME limit switches **8**



VP limit switches **12**



VT limit switches **16**



VM limit switches **20**

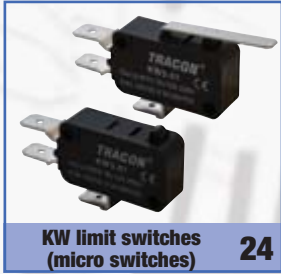

KW limit switches (micro switches) **24**



Enclosures **26**



Simple pushbuttons **27**



Projecting pushbuttons **27**



Pushbuttons with rubber boot **27**



Pushbuttons with symbols **28**



Pushbuttons with built-in signal light (Ba9s) **28**



Pushbuttons with mushroom head **29**



Emergency pushbuttons with mushroom head **29**

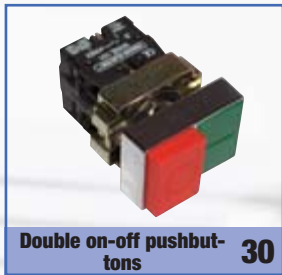

Double on-off pushbuttons **30**



Signal lamps (Ba9s) **31**

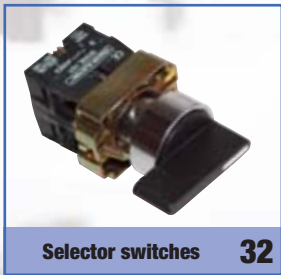

Selector switches **32**



Key switches **33**



Selector switches with built-in signal light (Ba9s) **33**



Pushbuttons **34**



Pushing switches **34**



Signal lamps (Ba9s) **35**



LED signal bulbs (new version) **36**



Contact elements **36**



Reduction rings **36**



Relay safety switches **37**



NYG2 Pushbutton product family **38**



Head units **39**



Light (LED) units **40**



Contact units **40**



LJL type LED signal lamps **42**



TES device switches **44**



Small disconnecter transformers TVTR **48**



One-phase insulating transformers TVTRB **50**



LS15 limit switches, version with spring handle

<b>I<sub>th</sub></b> 15 A	<b>I<sub>e</sub></b> (AC 1, 230 V) 5 A	<b>I<sub>e</sub></b> (AC 15, 230 V) 2 A	<b>I<sub>e</sub></b> (DC 13, 250 V) 0,3 A	<b>U<sub>i</sub></b> 250 V	<b>[mm<sup>2</sup>]</b> 0,5-1,5	<b>×10<sup>6</sup></b>	ON-OFF-ON... sc/h ×1.800	<b>T<sub>a</sub></b> -25...+55°C	<b>IP</b> 00
-------------------------------	---	--	--	-------------------------------	------------------------------------	------------------------	--------------------------------	-------------------------------------	-----------------

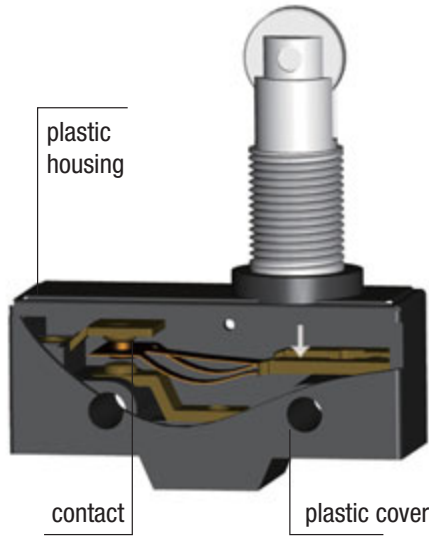

Type of contact: C

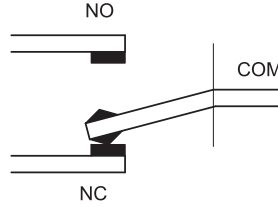

RELEVANT STANDARD  
EN 60947-5-1

- Strong housing
- Changeover contact
- Contact point for ring terminals
- Easy wire connection
- With different type switching mechanism

Version with spring handle

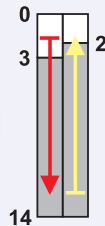

Operating distance (mm)

TRACON LS15GM-B

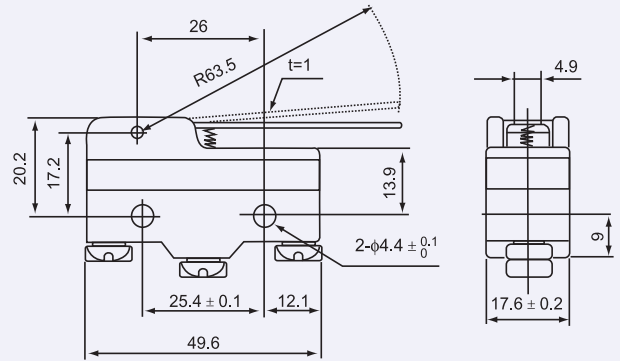

Version with spring handle

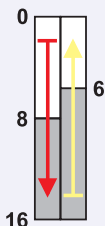

Operating distance (mm)

TRACON LS15GW-B

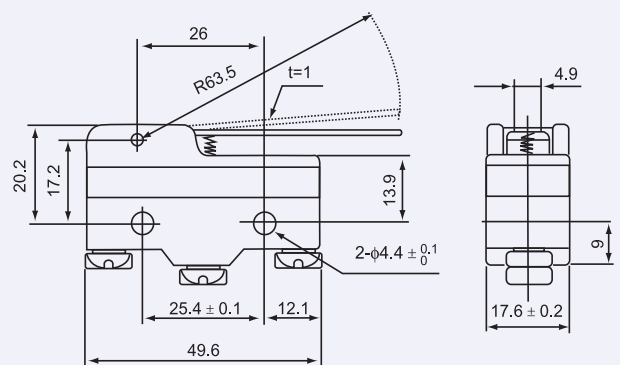

Version with spring handle

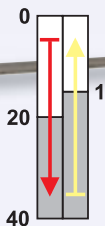

Operating distance (mm)

TRACON LS15HW24-B

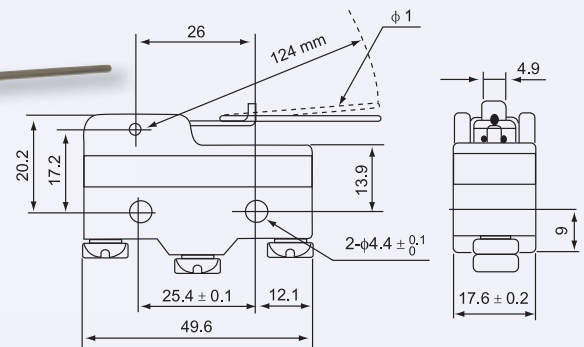



Version with spring handle

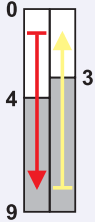

Operating distance (mm)

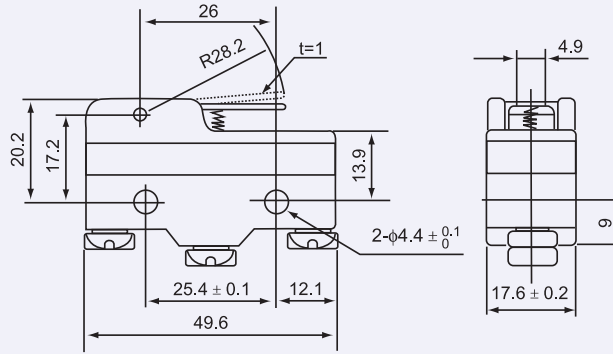

TRACON LS15GW21-B

Version with spring handle and roll

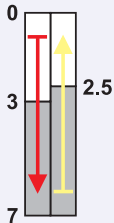

Operating distance (mm)

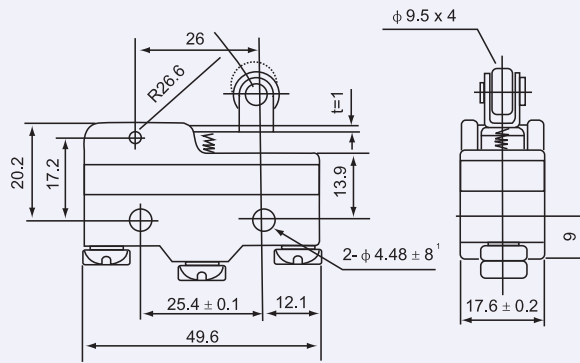

TRACON LS15GW22-B

Version with spring handle and roll

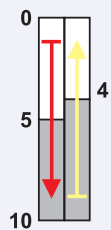

Operating distance (mm)

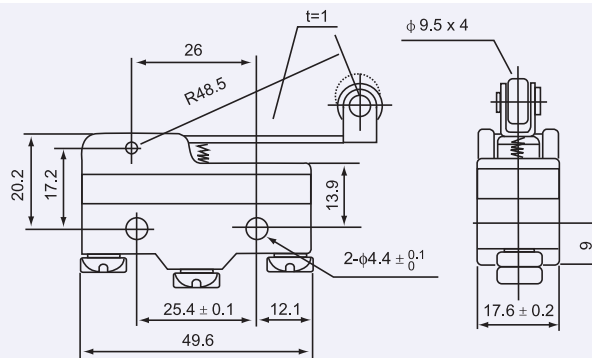

TRACON LS15GW2-B

Version with roll

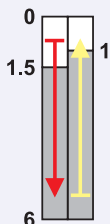

Operating distance (mm)

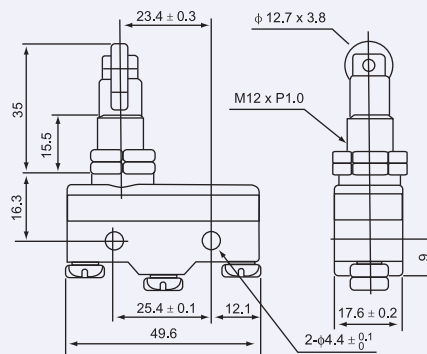

TRACON LS15GQ21-B



Version with roll

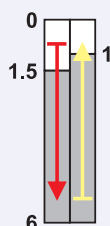

Operating distance (mm)

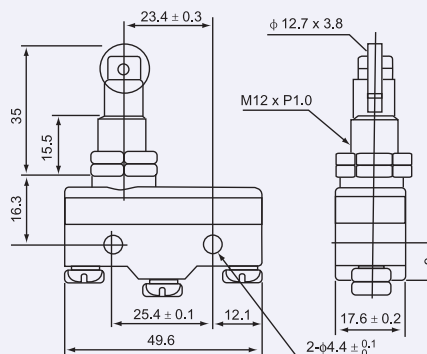

TRACON LS15GQ22-B



**Version with cone bumper**

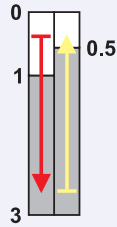

Operating distance (mm)

**TRACON LS15GD-B**

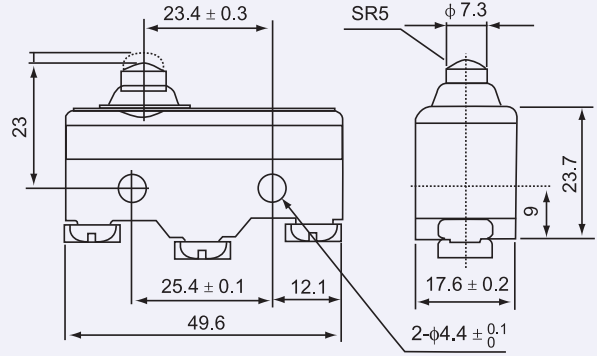

**Version with cone bumper**

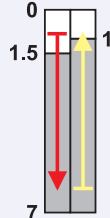

Operating distance (mm)

**TRACON LS15GQ-B**

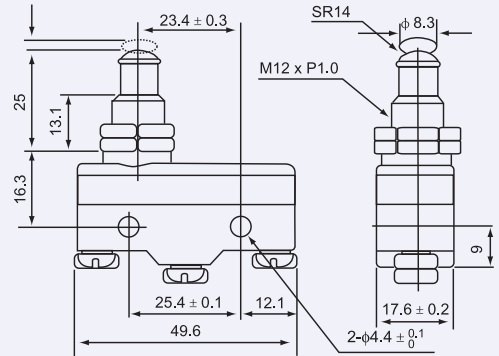

**Version with bumper**

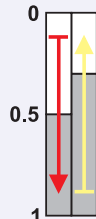

Operating distance (mm)

**TRACON LS15G-B**

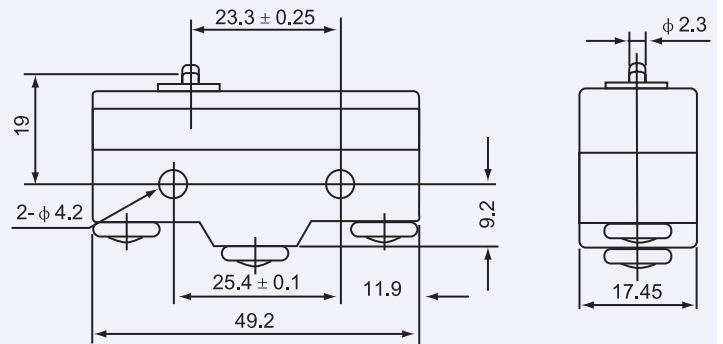

**Cover for LS15 limit switch**



IP 40



**TRACON LS15-COV**



**Key to electricity**

**TRACON ELECTRIC**

Tracon Key to electricity

# LS7 limit switches, version with spring handle

<b>I<sub>th</sub></b> 10 A	<b>I<sub>e</sub></b> (AC 1, 230 V) 5 A	<b>I<sub>e</sub></b> (AC 15, 230 V) 2 A	<b>I<sub>e</sub></b> (DC 13, 250 V) 0,3 A	<b>U<sub>i</sub></b> 250 V	<b>[mm<sup>2</sup>]</b> 0,5-1,5	<b>ON-OFF-ON...</b> sc/h x1.800	<b>T<sub>a</sub></b> -25...+55°C	<b>IP</b> 40
-------------------------------	---	--	--	-------------------------------	------------------------------------	---------------------------------------	-------------------------------------	-----------------



**RELEVANT STANDARD**  
**EN 60947-5-1**

- Strong housing
- Changeover contact
- Contact point for ring terminals
- Easy wire connection
- With different type switching mechanism

**Type of contact: C**

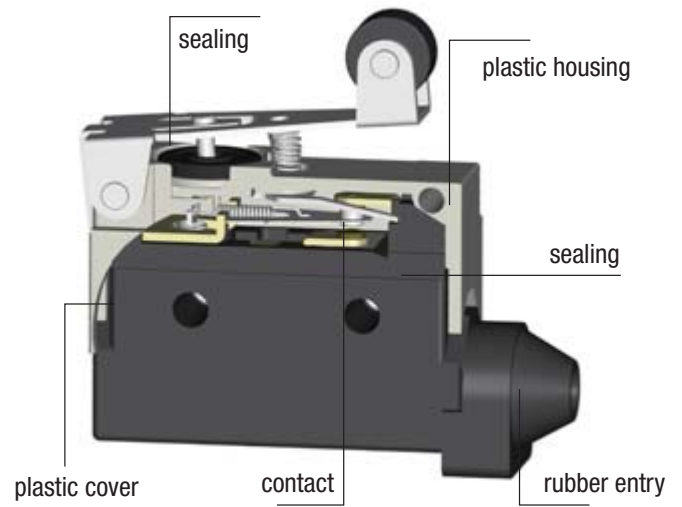
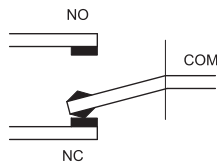

## Version with spring handle

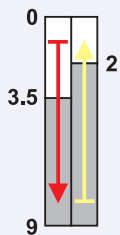

**Operating distance (mm)**

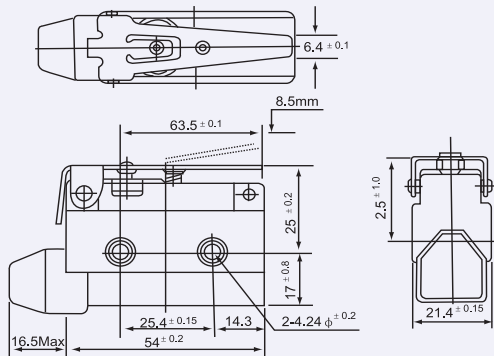

**TRACON LS7140**

## Version with spring handle

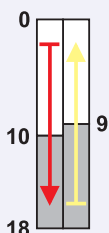

**Operating distance (mm)**

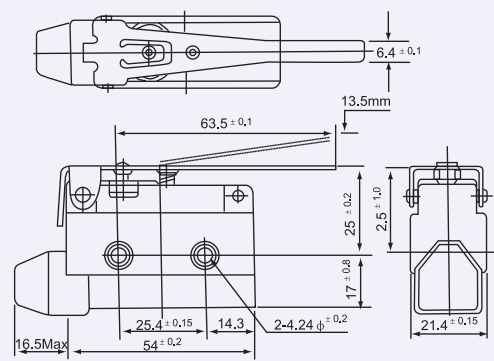

**TRACON LS7120**

## Version with spring handle and roll

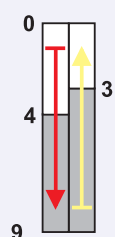

**Operating distance (mm)**

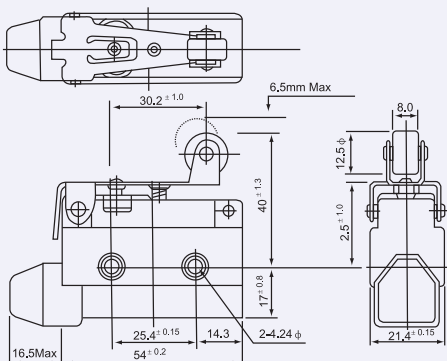

**TRACON LS7141**

Version with spring handle and roll

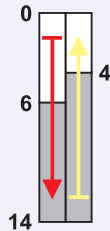

Operating distance (mm)

TRACON LS7121

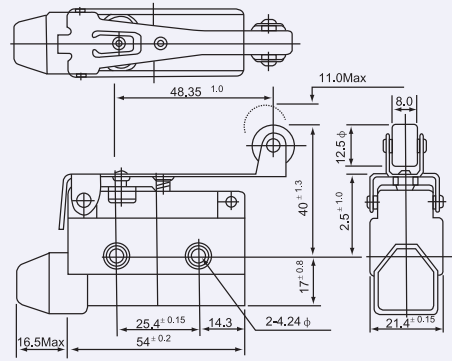

Version with spring handle and jointed roll

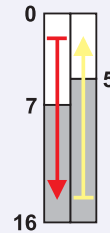

Operating distance (mm)

TRACON LS7144

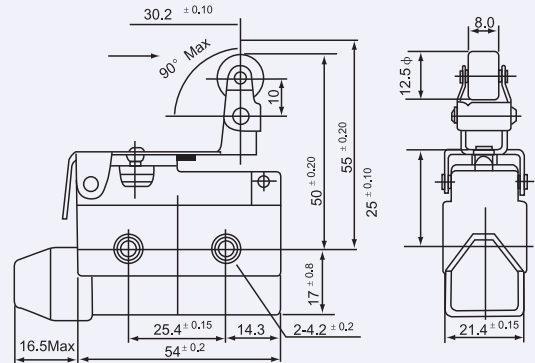

Version with spring handle and jointed roll

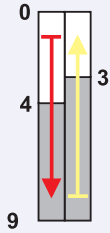

Operating distance (mm)

TRACON LS7124

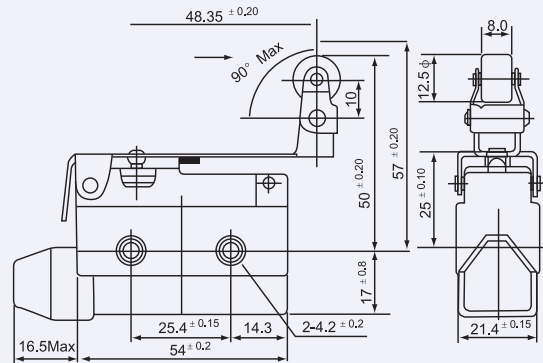

Version with cone bumper

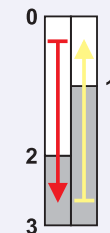

Operating distance (mm)

TRACON LS7100

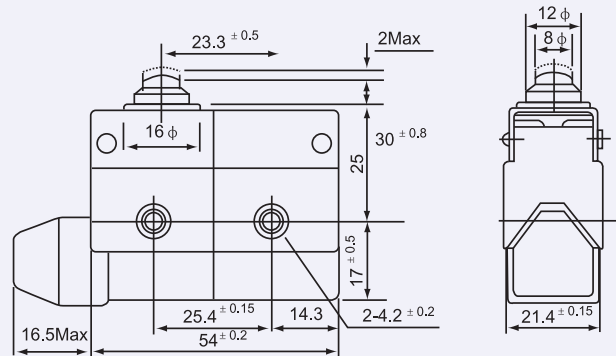

Version with cone bumper

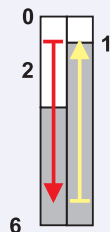

Operating distance (mm)

TRACON LS7110

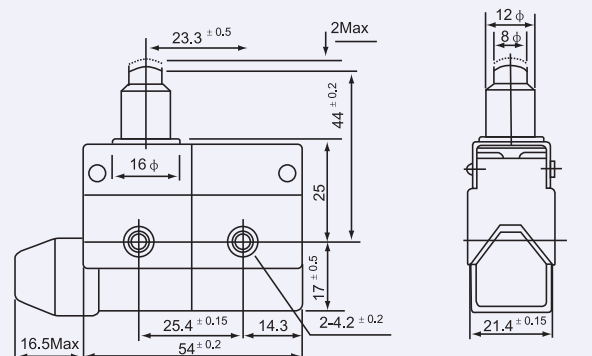

Version with cone bumper

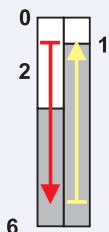

Operating distance (mm)

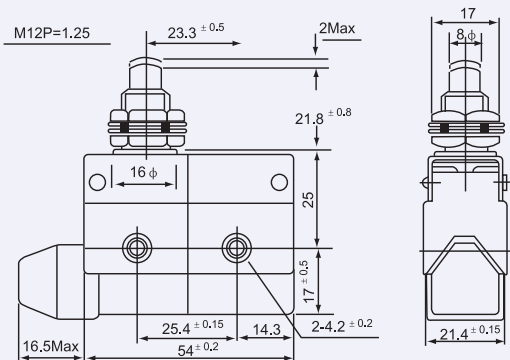

TRACON LS7310

Version with roll

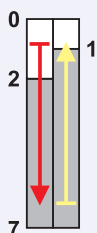

Operating distance (mm)

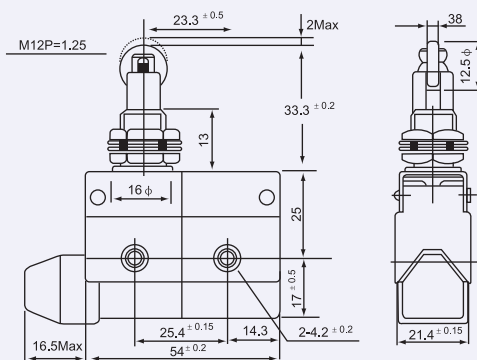

TRACON LS7311

Version with roll

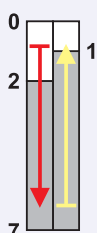

Operating distance (mm)

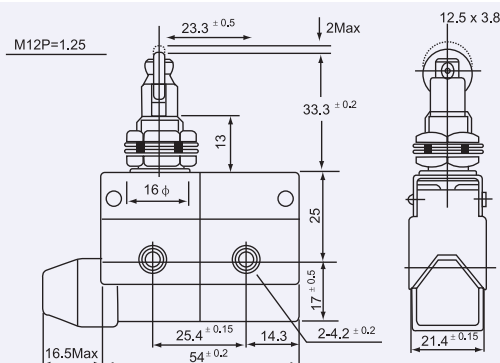

TRACON LS7312

Version with spring stick

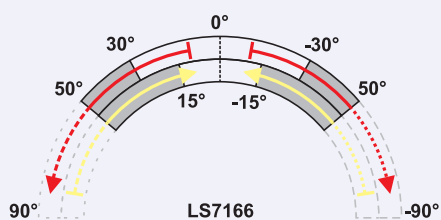

Operating distance (°)

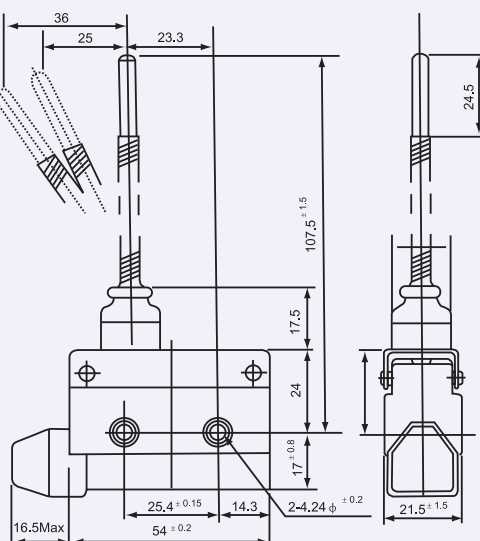

TRACON LS7166



LSME limit switches

<b>I<sub>th</sub></b> 10 A	<b>I<sub>e</sub></b> (AC 1, 230 V) 5 A	<b>I<sub>e</sub></b> (AC 15, 230 V) 2 A	<b>I<sub>e</sub></b> (DC 13, 230V) 0,3 A	<b>U<sub>i</sub></b> 500 V	<b>[mm<sup>2</sup>]</b> 0,5-1,5	<b>x10<sup>6</sup></b> x1.800	<b>ON-OFF-ON...</b> sc/h x1.800	<b>T<sub>a</sub></b> -25...+55°C	<b>IP</b> 65
-------------------------------	---	--	---	-------------------------------	------------------------------------	----------------------------------	---------------------------------------	-------------------------------------	-----------------

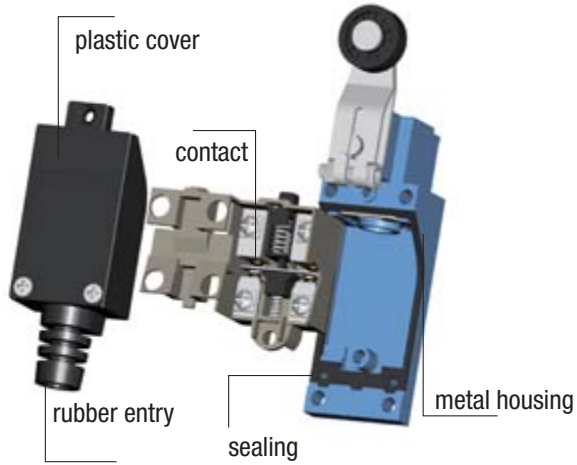

Type of contact: Za

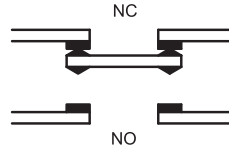

RELEVANT STANDARD  
**EN 60947-1**

RELEVANT STANDARD  
**EN 60947-5-1**

- double contacts
- massive construction
- plastic and aluminum die-cast
- water- and oilproof
- double spring mechanism
- long lifetime
- easy wiring

Version with spring stick

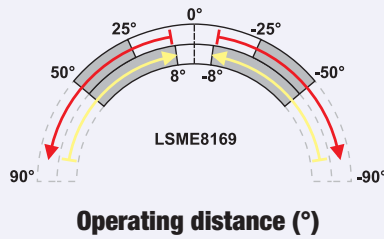

TRACON LSME8169

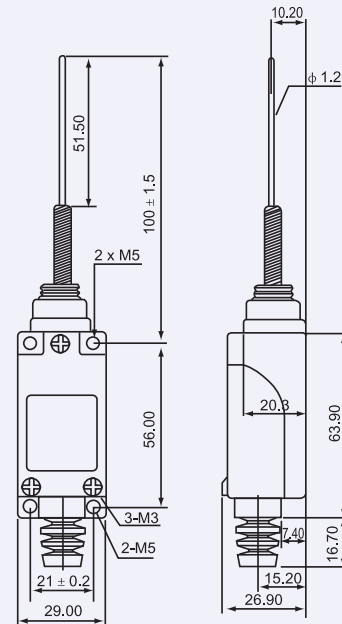

Version with spring stick

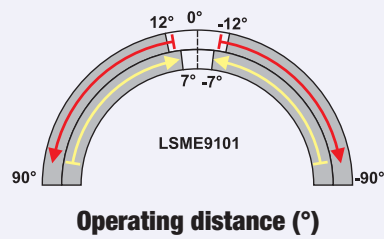

TRACON LSME9101

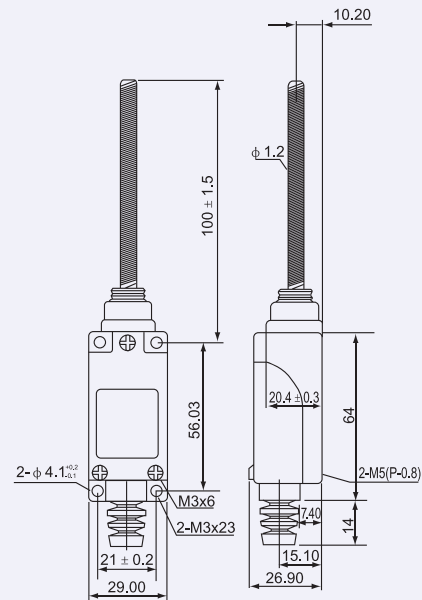

Version with spring stick

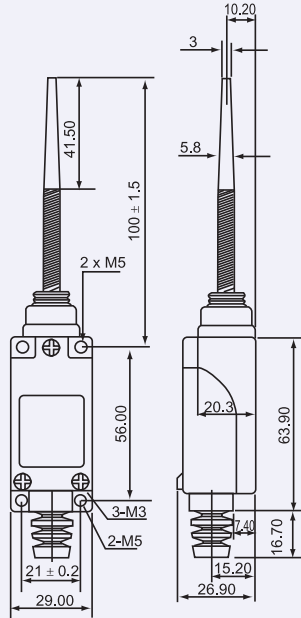
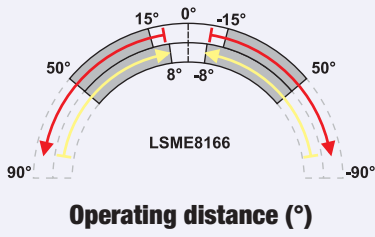

TRACON LSME8166

Version with cone bumper

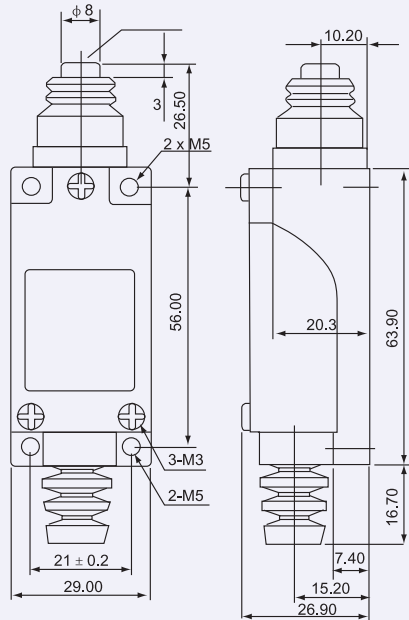
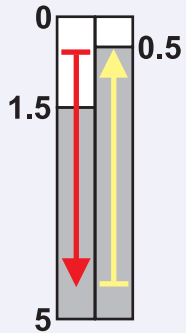

TRACON LSME8111

Version with roll

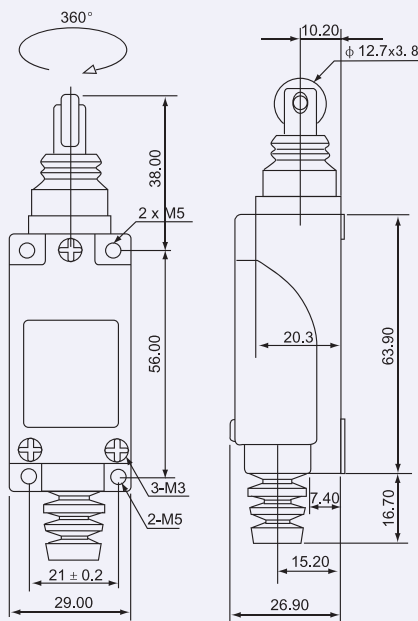
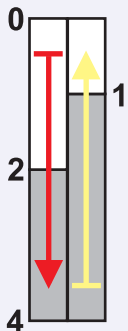

TRACON LSME8122

Version with twisting arm and stick

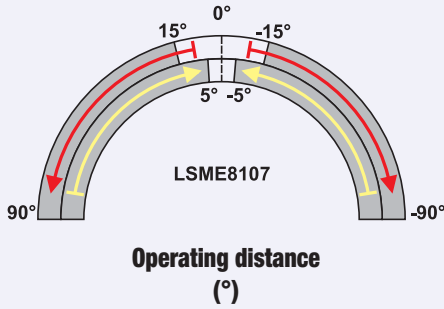

TRACON LSME8107

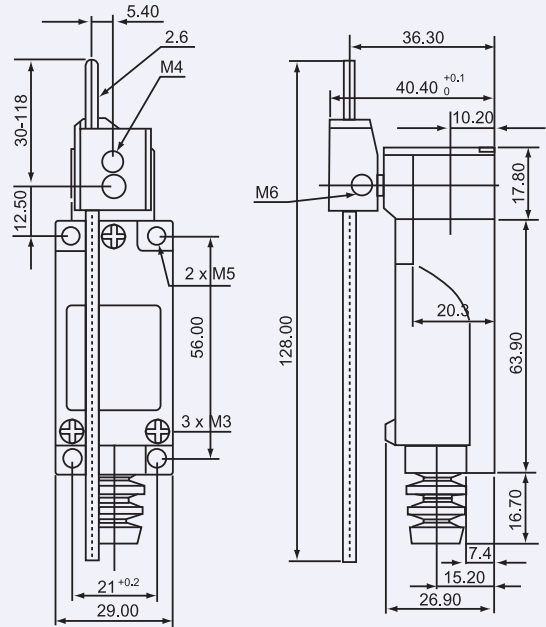

Version with roller bumper

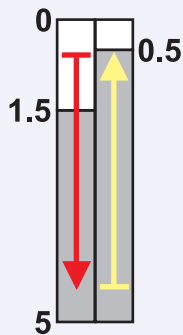

TRACON LSME8112

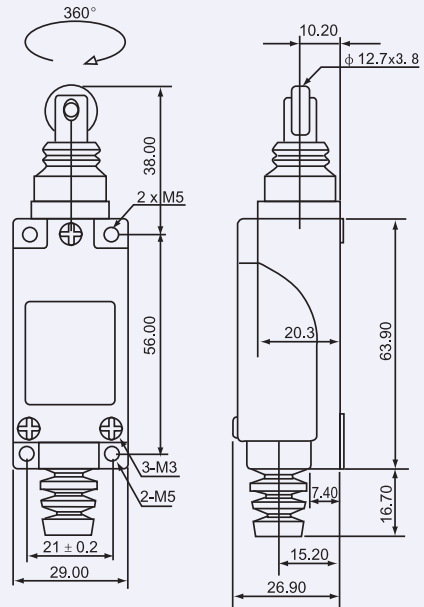

Version with twisting arm and roll

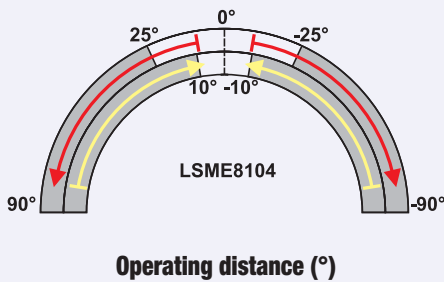

TRACON LSME8104

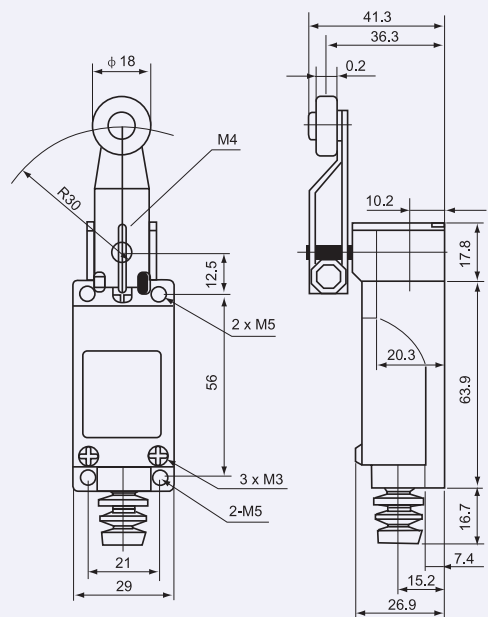

Version with adjustable spring handle and jointed roll

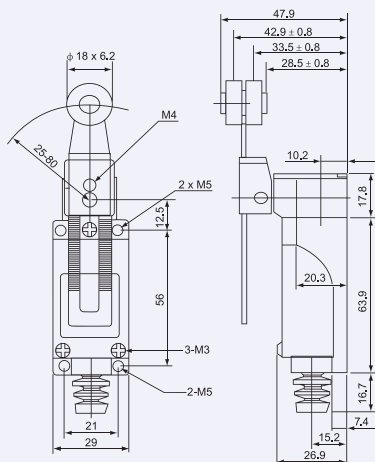
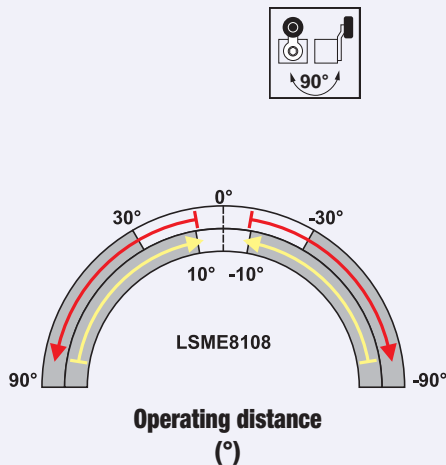

TRACON LSME8108

# IF YOU NEED THE BEST GRIP!

Wide color and size range  
High quality



## SCAN THE QR CODE!

- Check our new products
- Be updated

Our assortment is expanding quickly and continuously! Our catalogue shows the assortment of January 2017. Be up to date by our web page!



VP limit switches

<b>I<sub>th</sub></b> 10 A	<b>I<sub>e</sub></b> (AC 1, 230 V) 5 A	<b>I<sub>e</sub></b> (AC 15, 230 V) 2 A	<b>I<sub>e</sub></b> (DC 13, 250 V) 0,3 A	<b>U<sub>i</sub></b> 500 V	<b>[mm<sup>2</sup>]</b> 0,75-1,5	<b>5 × 10<sup>6</sup></b>	ON-OFF-ON... ↑ <b>sc/h</b> ×1.800	<b>T<sub>a</sub></b> -25...+55°C	<b>IP</b> 65
-------------------------------	---	--	--	-------------------------------	-------------------------------------	---------------------------	--	-------------------------------------	-----------------

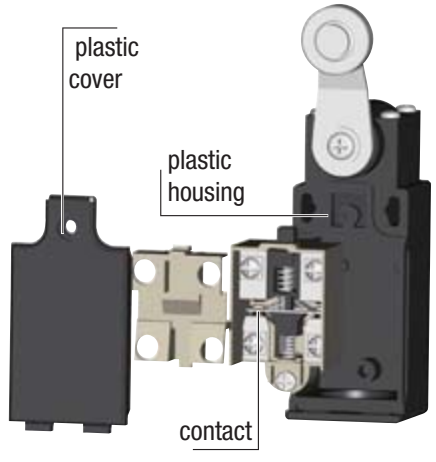

Type of contact: **Za**

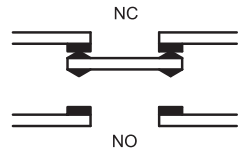

- double contacts
- strong plastic cover
- massive construction
- precise switching
- long lifetime
- easy wiring

RELEVANT STANDARD  
**EN 60947-5-1**

RELEVANT STANDARD  
**EN 60947-1**

Version with twisting arm

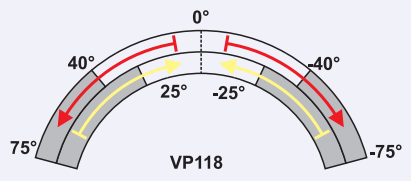
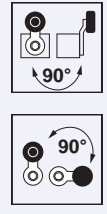

Operating distance (°)

**TRACON VP118**

d = 18 mm  
metal roller

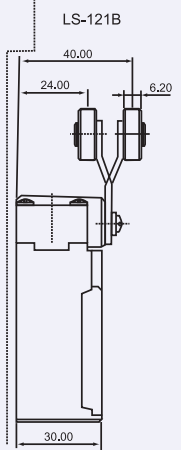
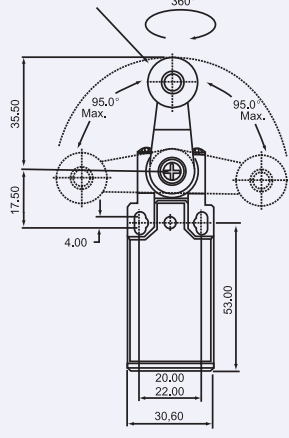

Version with twisting arm

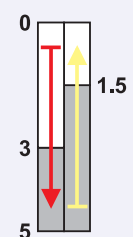
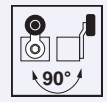

Operating distance (mm)

**TRACON VP121**

d = 12,7 mm  
metal roller

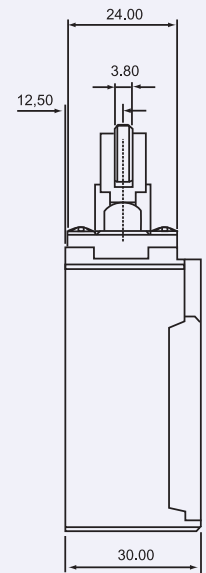
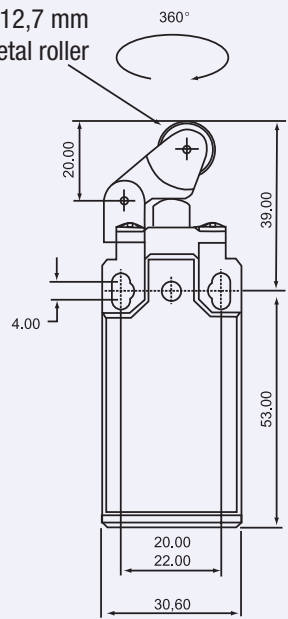

Version with adjustable rolling arm

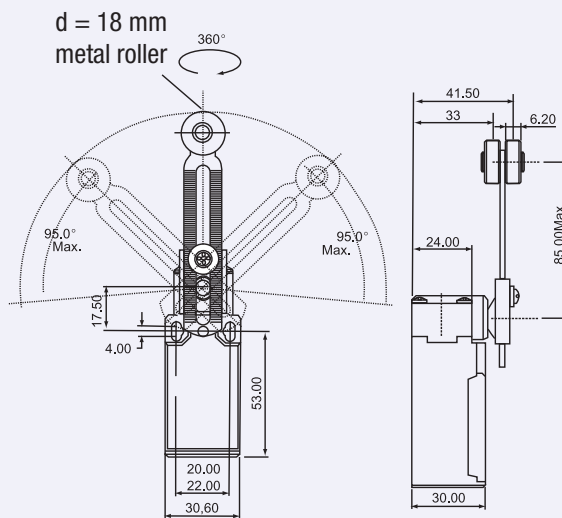
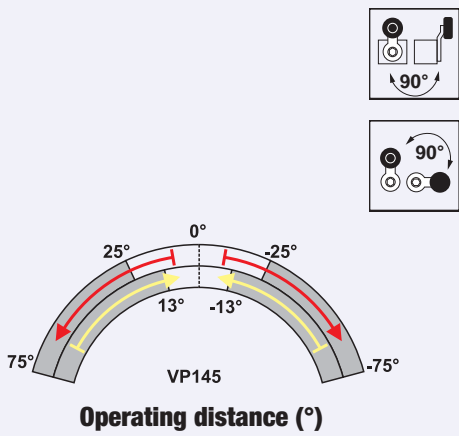

TRACON VP145

Operation directions

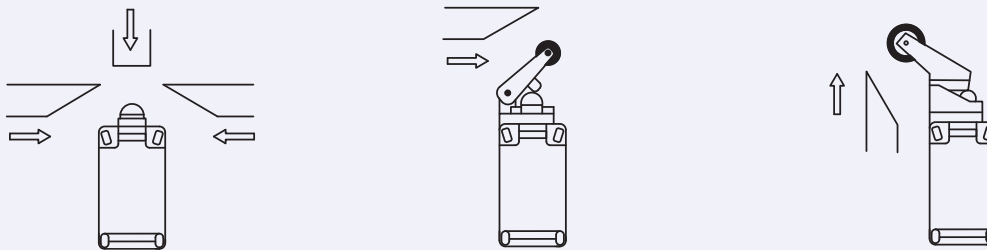

# THE PROPER TYPE FOR ALL APPLICATIONS

Plastic / metal

4-64 modules

Wall and recessed mount types

**TRACON**  
ELECTRIC®



Version with spring stick

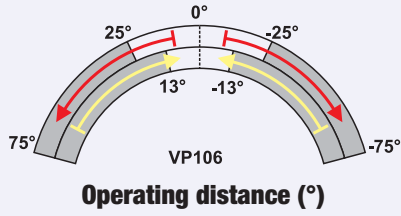

TRACON VP106

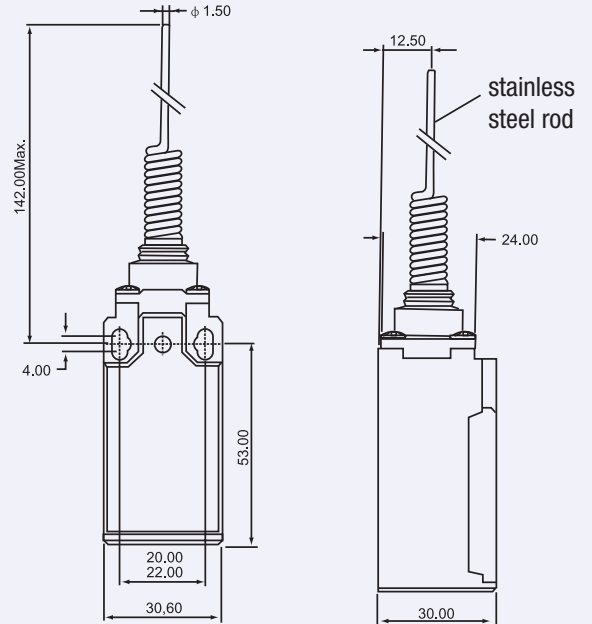

Version with roller bumper

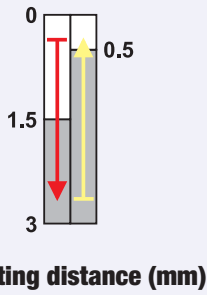

TRACON VP102

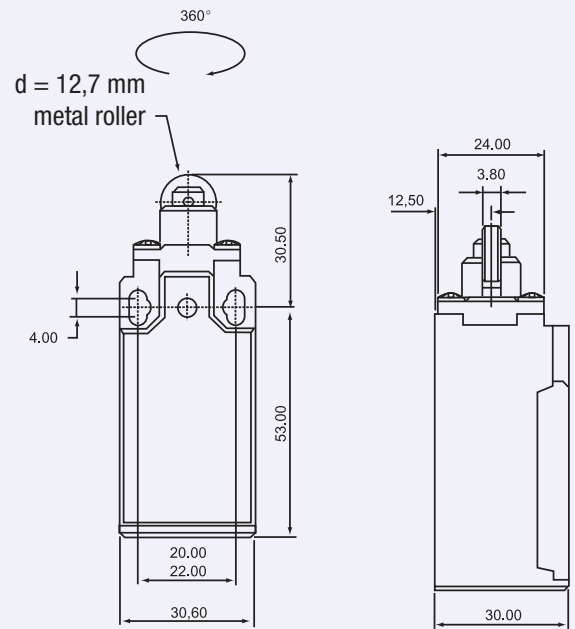

Version with cone bumper

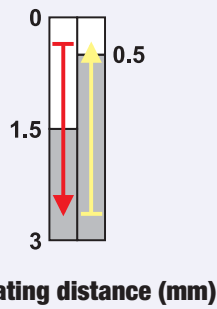

TRACON VP110

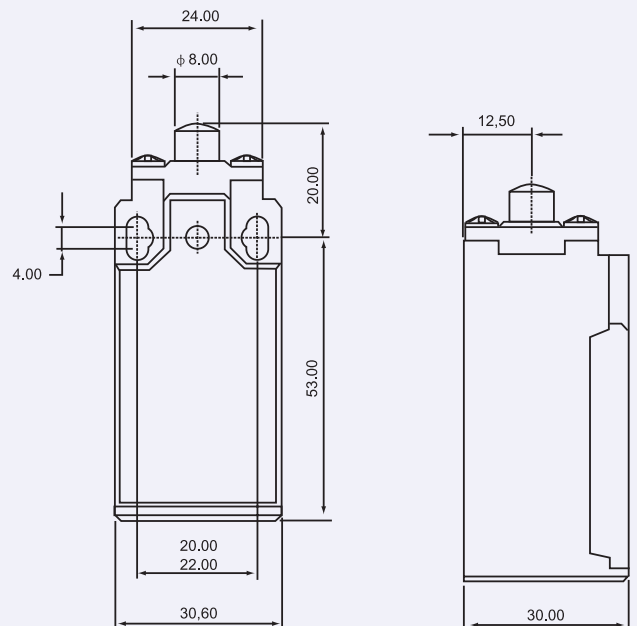

Version with twisting arm

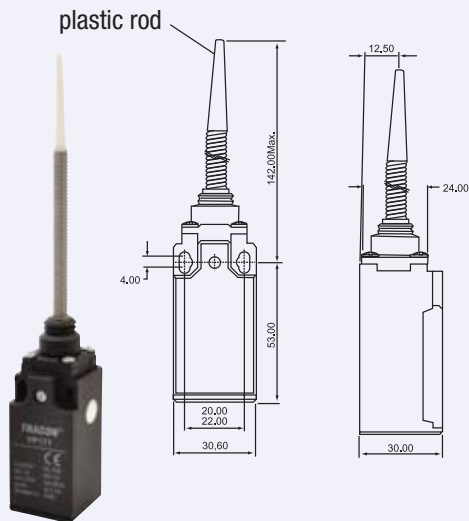

TRACON VP171

Version with roller bumper

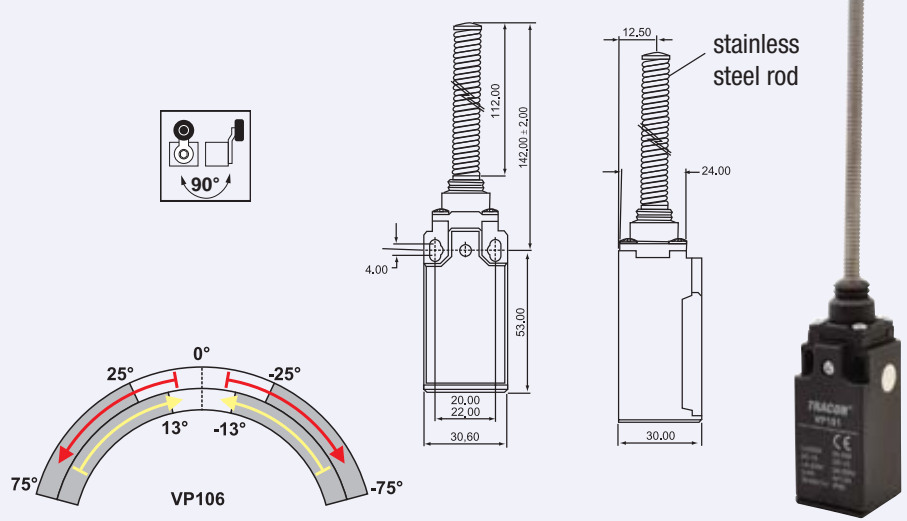

TRACON VP181

Version with spring stick

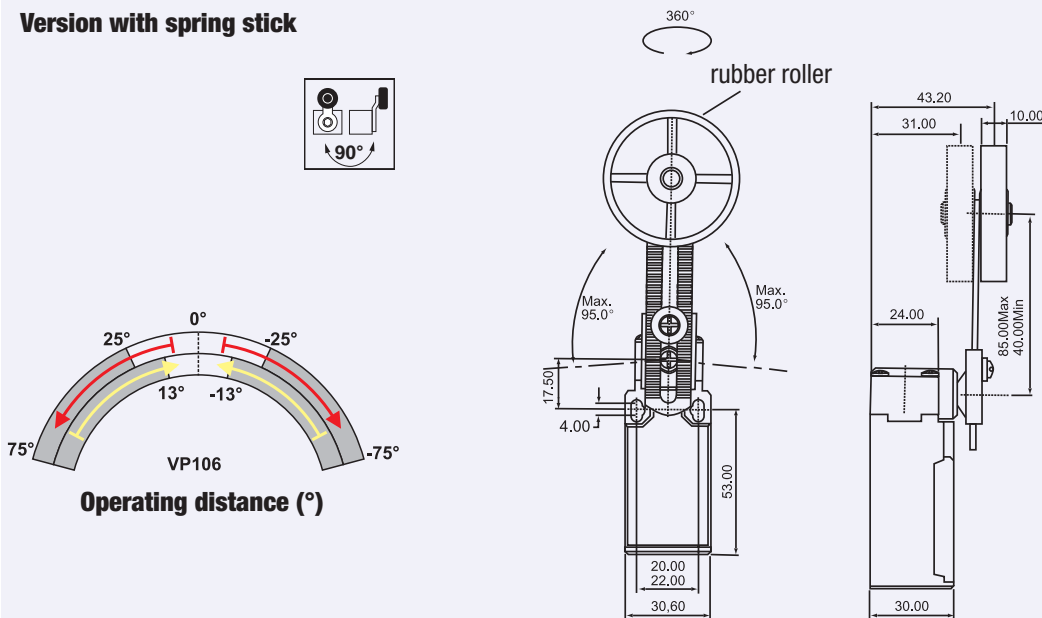

TRACON VP191

Version with cone bumper

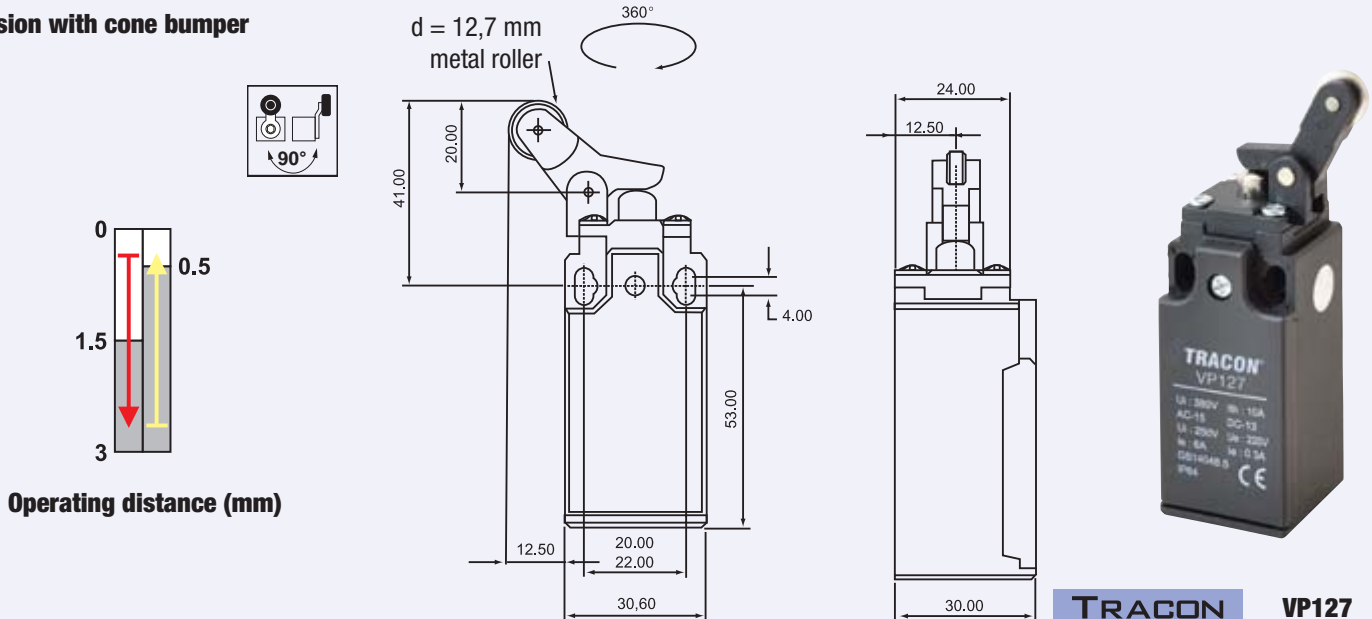

TRACON VP127



VT limit switches

<b>I<sub>th</sub></b> 10 A	<b>I<sub>e</sub></b> (AC 1, 230 V) 5 A	<b>I<sub>e</sub></b> (AC 15, 230 V) 2 A	<b>I<sub>e</sub></b> (DC 13, 220 V) 0,3 A	<b>U<sub>i</sub></b> 500 V	<b>[mm<sup>2</sup>]</b> 0,75-1,5	<b>x10<sup>7</sup></b> x1.800	<b>ON-OFF-ON...</b> sc/h	<b>T<sub>a</sub></b> -25...+55°C	<b>IP</b> 65
-------------------------------	---	--	--	-------------------------------	-------------------------------------	----------------------------------	-----------------------------	-------------------------------------	-----------------

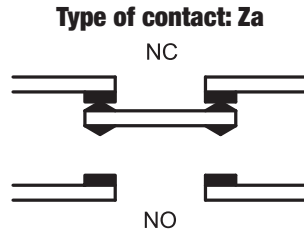
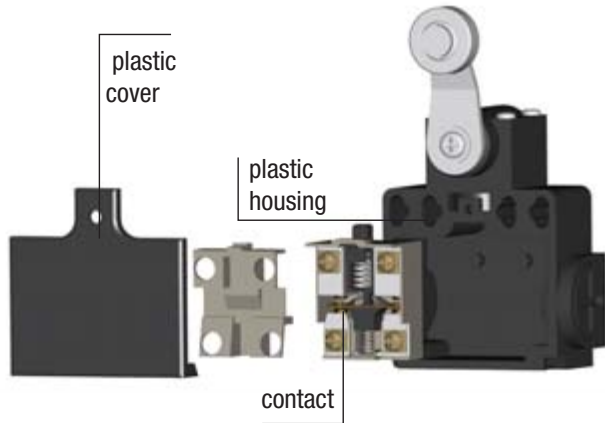

RELEVANT STANDARD  
**EN 60947-1**

RELEVANT STANDARD  
**EN 60947-5-1**

- double contacts
- strong plastic cover
- massive construction
- precise switching
- long lifetime

Version with roller bumper

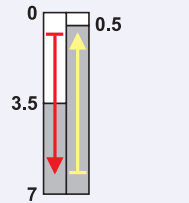

Operating distance (mm)

TRACON VT102

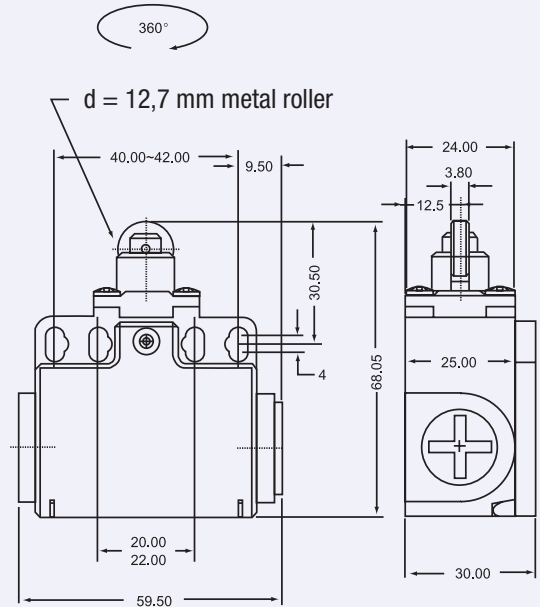

Version with cone bumper

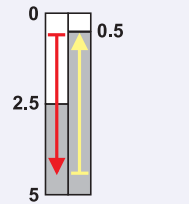

Operating distance (mm)

TRACON VT110

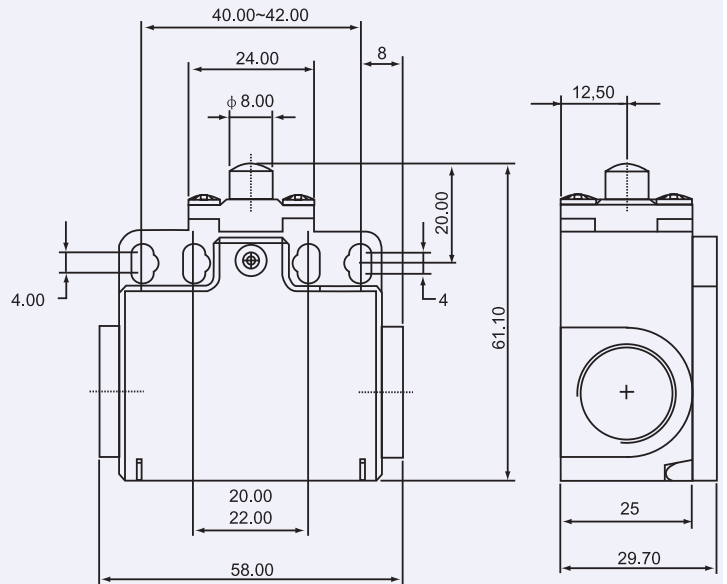

Version with cone bumper

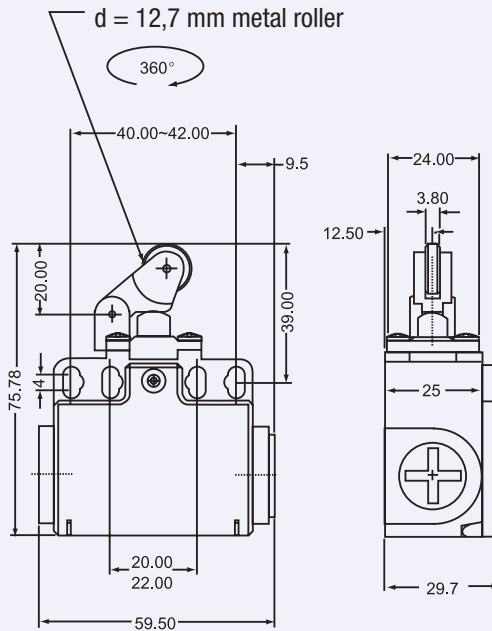
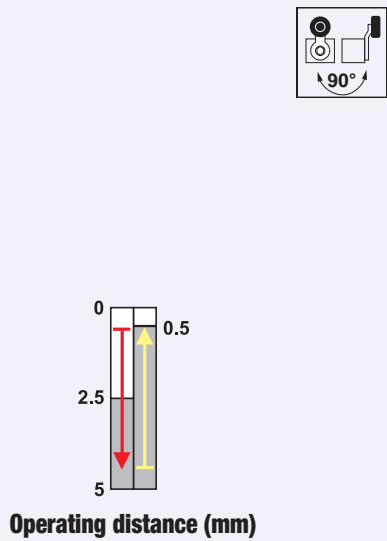

TRACON VT121

Version with twisting arm and roll

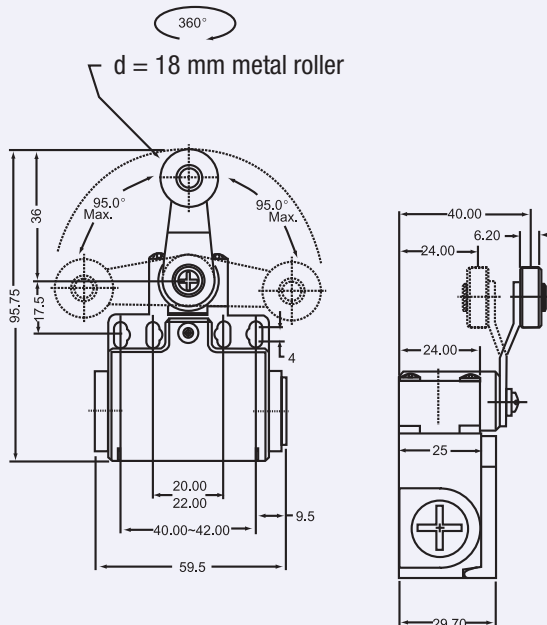
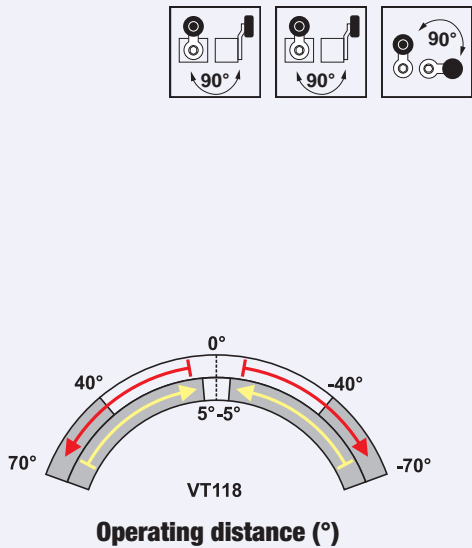

TRACON VT118

Version with roller bumper

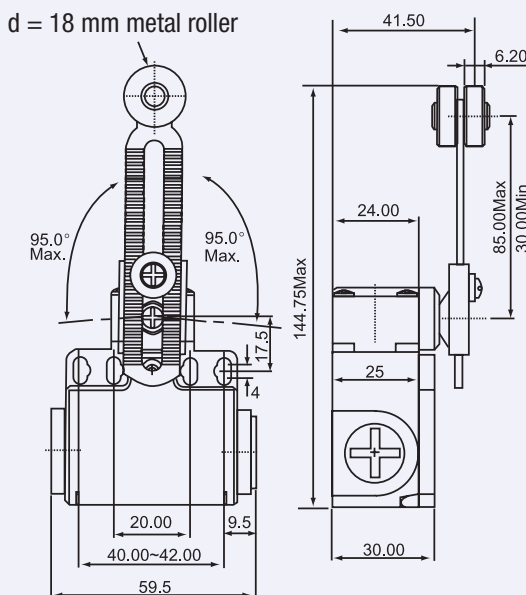
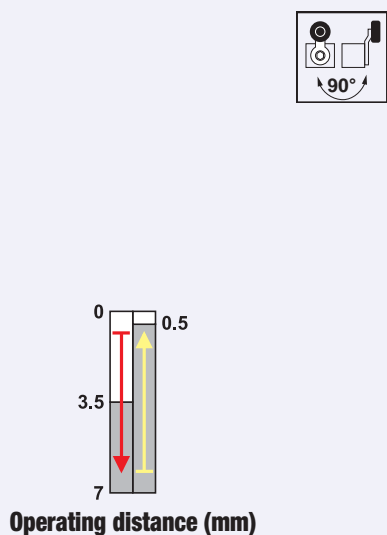

TRACON VT145

Version with cone bumper

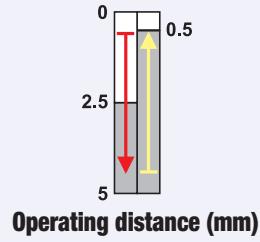

TRACON VT181

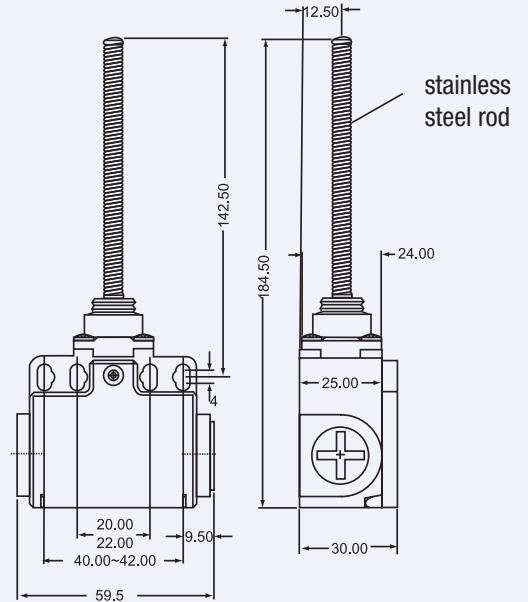

Version with roller bumper

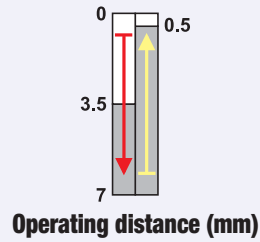

TRACON VT106

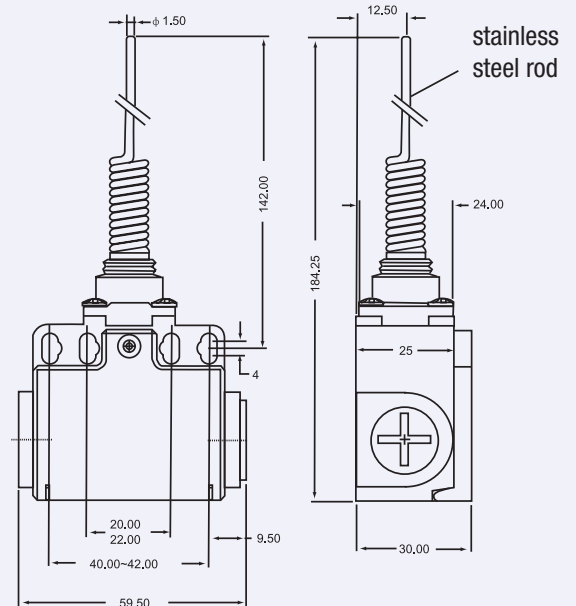

Version with cone bumper

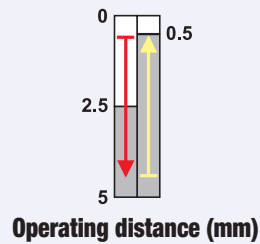

TRACON VT127

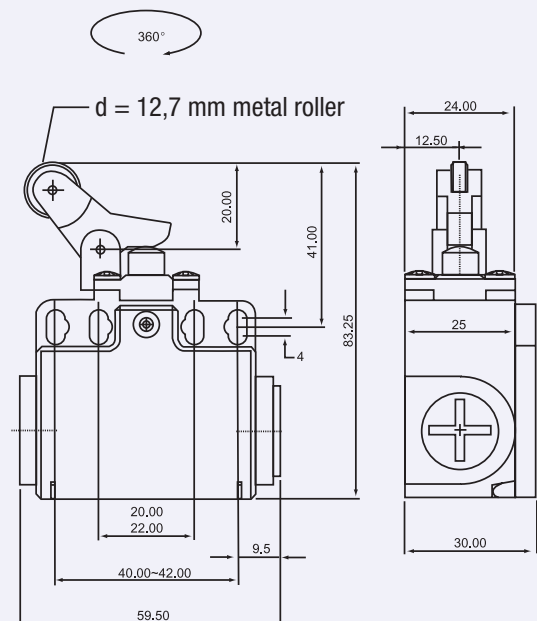

Version with roller bumper

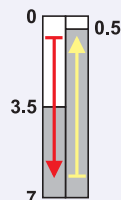

Operating distance (mm)

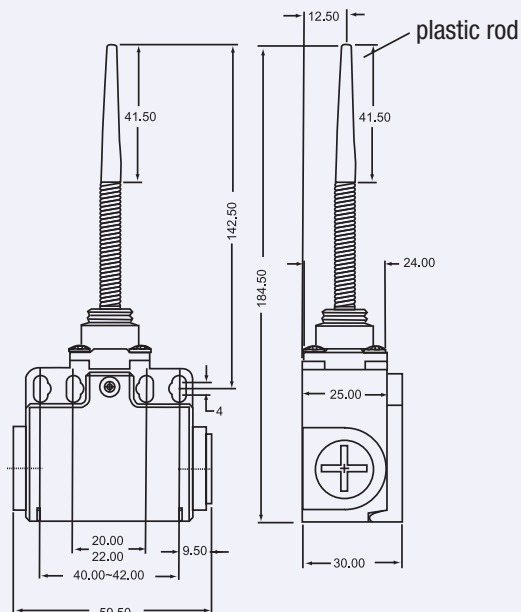

TRACON VT171

Version with cone bumper

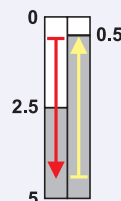

Operating distance (mm)

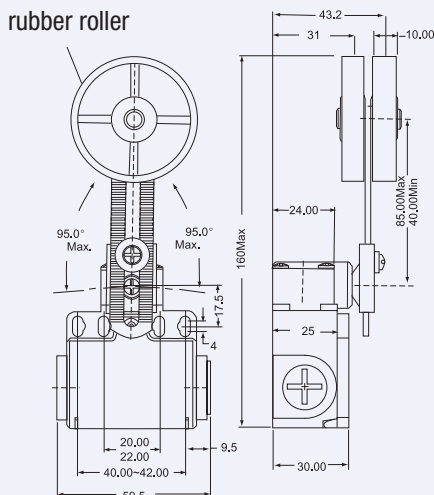

TRACON VT191



**Key to electricity**

TRACON ELECTRIC

Tracon Key to electricity



SCAN THE QR CODE!

- Check our new products
- Be updated

Our assortment is expanding quickly and continuously! Our catalogue shows the assortment of January 2017. Be up to date by our web page!



VM limit switches

<b>I<sub>th</sub></b> 10 A	<b>I<sub>e</sub></b> (AC 1, 230 V) 5 A	<b>I<sub>e</sub></b> (AC 15, 230 V) 2 A	<b>I<sub>e</sub></b> (DC 13, 250 V) 0,3 A	<b>U<sub>i</sub></b> 500 V	<b>[mm<sup>2</sup>]</b> 0,75-1,5	<b>5 × 10<sup>6</sup></b>	ON-OFF-ON... sc/h ×3.600	<b>T<sub>a</sub></b> -25...+55°C	<b>IP</b> 66	
-------------------------------	---	--	--	-------------------------------	-------------------------------------	---------------------------	--------------------------------	-------------------------------------	-----------------	--

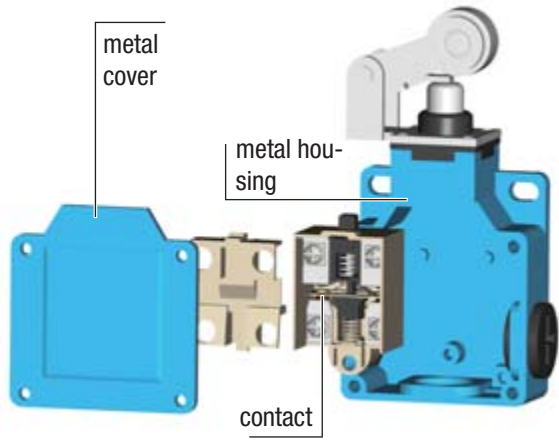

Type of contact: Za

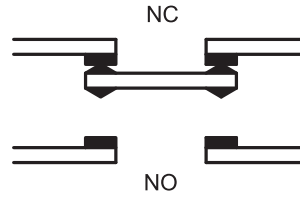

- double contacts
- strong metal cover
- massive construction
- water- and oilproof
- long lifetime
- easy wiring

RELEVANT STANDARD  
**EN 60947-1**

RELEVANT STANDARD  
**EN 60947-5-1**

TÜV MEEI TEST DOCUMENTATION  
**D0525V123**

Version with cone bumper

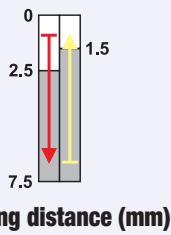

Operating distance (mm)

**TRACON VM110**

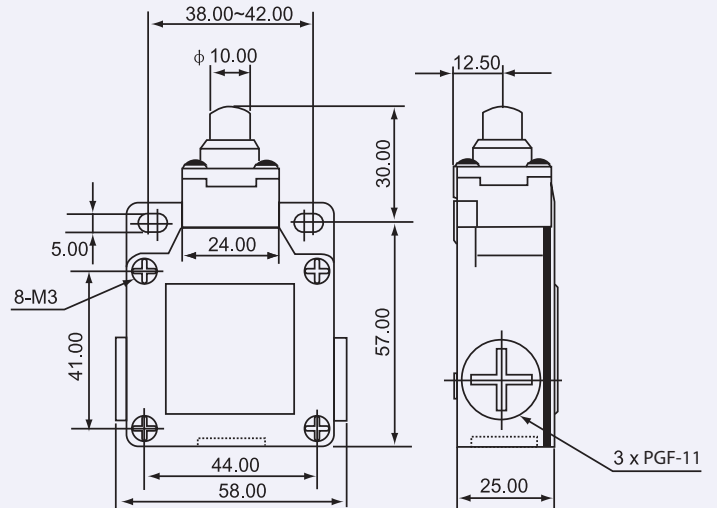

Version with roller bumper

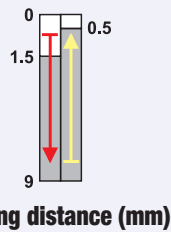

Operating distance (mm)

**TRACON VM102**

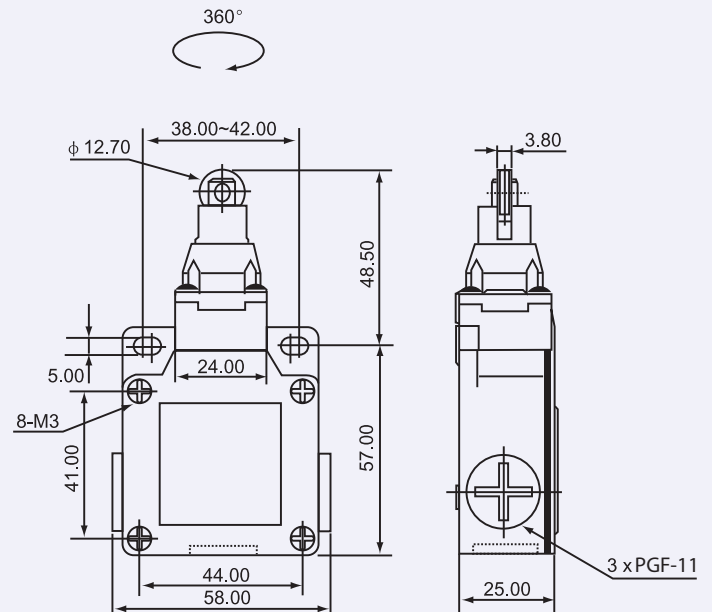

Version with roller bumper on arm

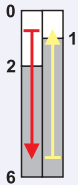

Operating distance (mm)

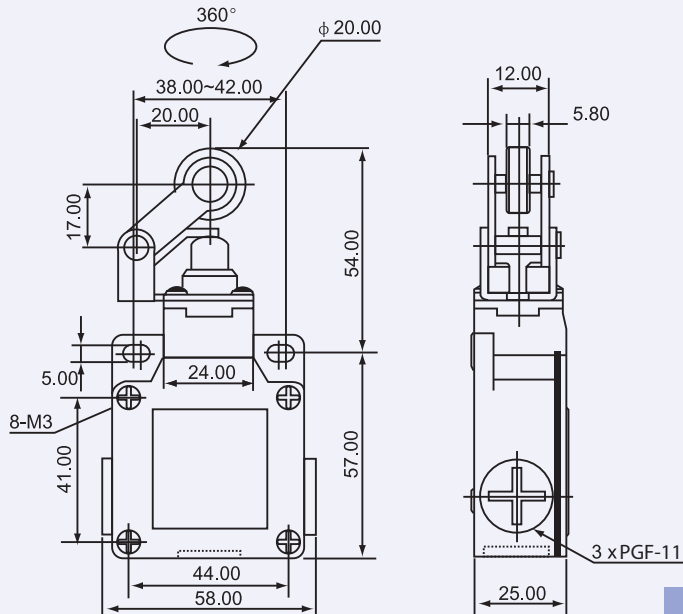

TRACON VM121

Version with twisting arm

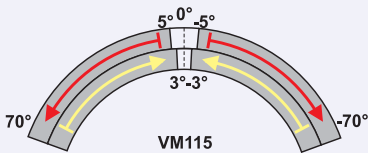
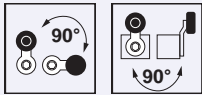

Operating distance (°)

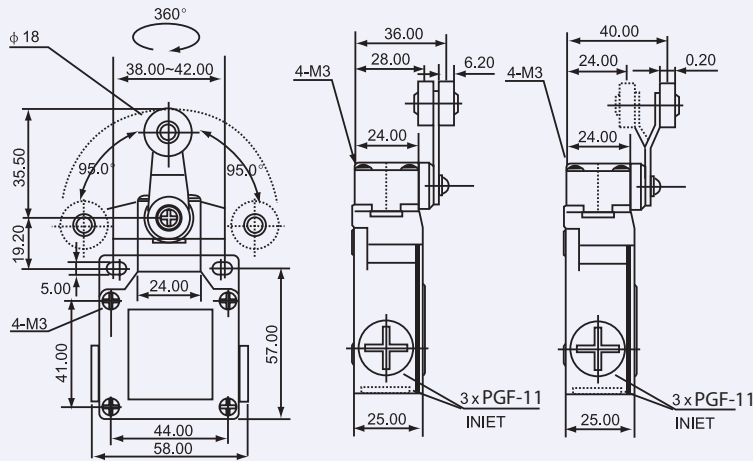

TRACON VM115

Version with spring stick

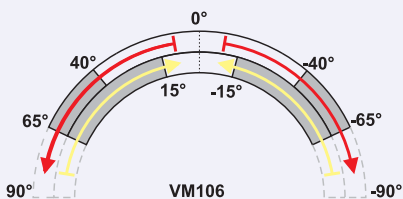

Operating distance (°)

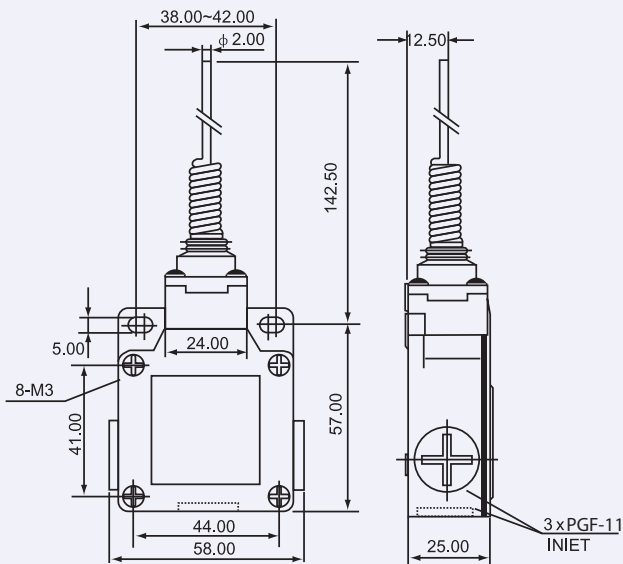

TRACON VM106

Version with cone bumper

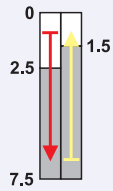

Operating distance (mm)

TRACON VM145

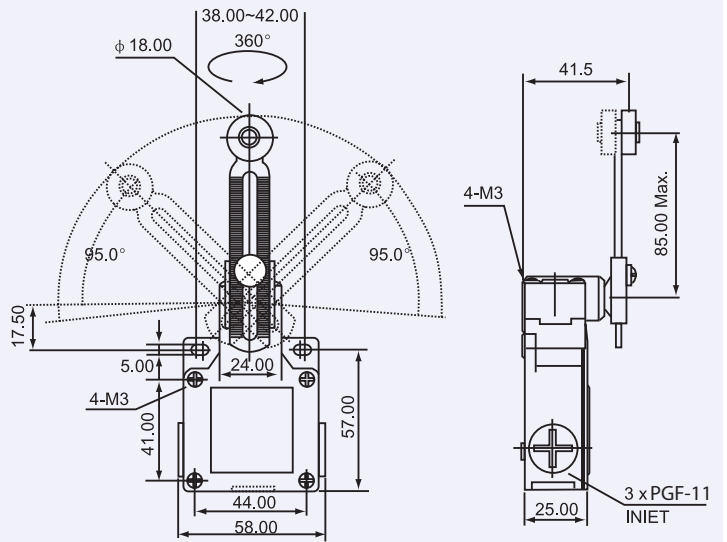

Version with roller bumper

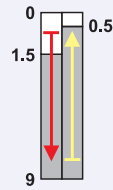

Operating distance (mm)

TRACON VM171

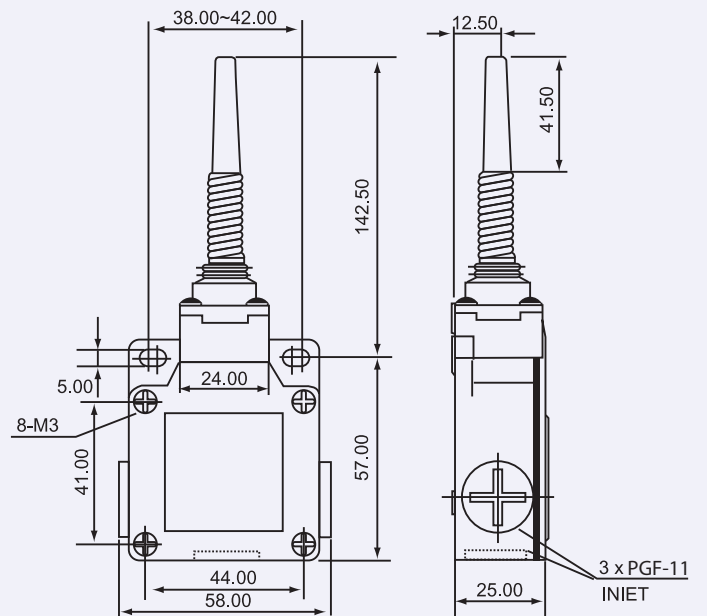

Version with roller bumper on arm

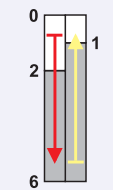

Operating distance (mm)

TRACON VM181

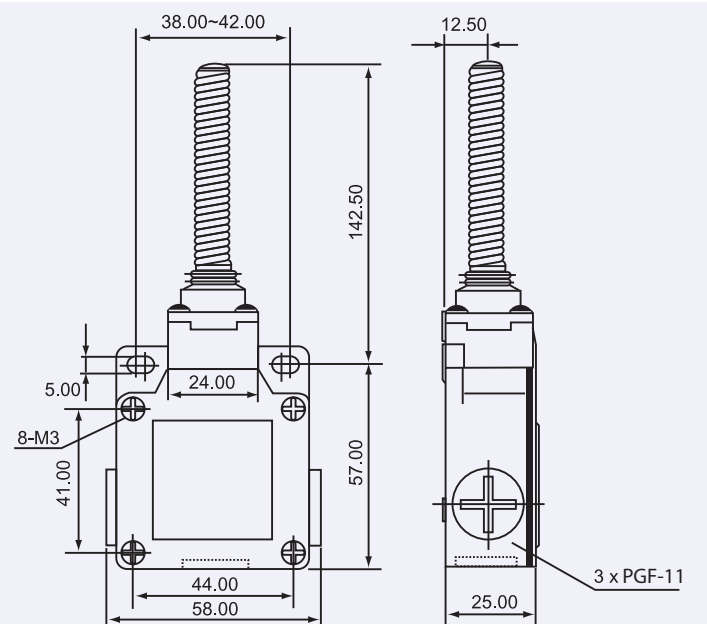

## LED STREETLIGHTS AND HIGH BAY LIGHTS

Die casted aluminum housing

Meanwell driver

Epistar chip

5 years Guarantee

**TRACON**  
.....ELECTRIC®



## LED PANELS

Wall and recessed mount types

From 6 W to 48 W

For household and office use

**TRACON**  
.....ELECTRIC®





**KW limit switches (micro switches)**

<b>I<sub>th</sub></b> 10 A	<b>I<sub>e</sub></b> (AC 1, 230 V) 5 A	<b>I<sub>e</sub></b> (AC 15, 230 V) 2 A	<b>I<sub>e</sub></b> (DC 13, 250 V) 0,3 A	<b>U<sub>i</sub></b> 500 V	<b>[mm<sup>2</sup>]</b> 0,75-1,5	<b>ON-OFF-ON...</b> sc/h x600	<b>T<sub>a</sub></b> -25...+80°C	<b>IP</b> 00
-------------------------------	---	--	--	-------------------------------	-------------------------------------	-------------------------------------	-------------------------------------	-----------------

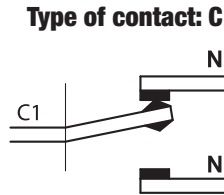
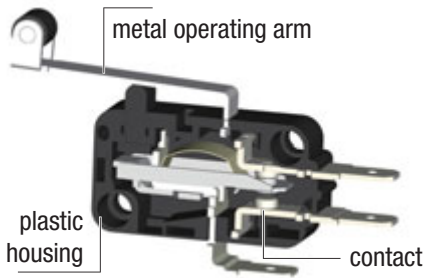

**RELEVANT STANDARD**  
**EN 60947-1**

**RELEVANT STANDARD**  
**EN 60947-5-1**

**Version with bumper**

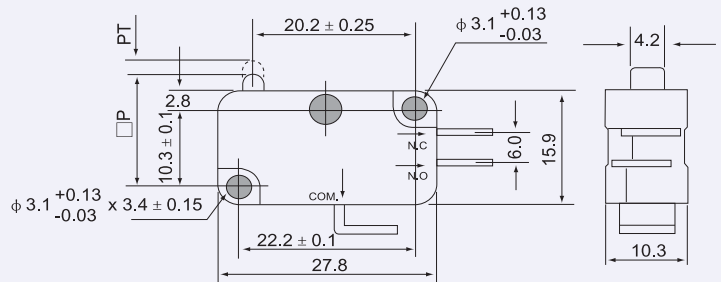
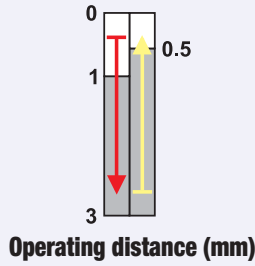

<b>TRACON</b>	
<b>KW3-01</b>	6,3×0,8 mm
<b>KW3-05</b>	4,8×0,8 mm

**Version with spring handle**

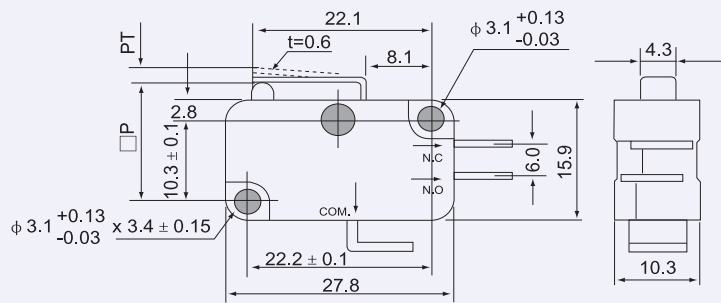
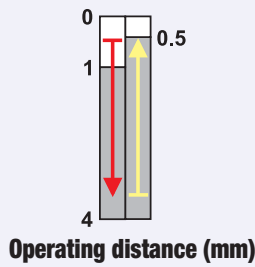

<b>TRACON</b>	
<b>KW3-11</b>	6,3×0,8 mm
<b>KW3-15</b>	4,8×0,8 mm

**Version with spring handle**

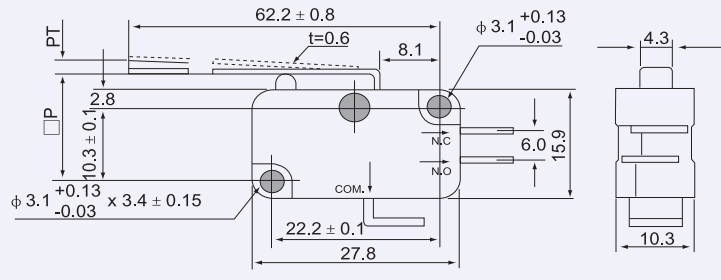
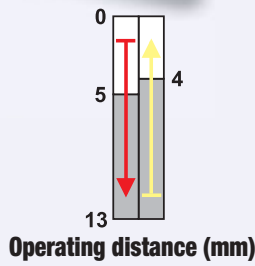

<b>TRACON</b>	
<b>KW3-21</b>	6,3×0,8 mm
<b>KW3-25</b>	4,8×0,8 mm

Version with spring handle

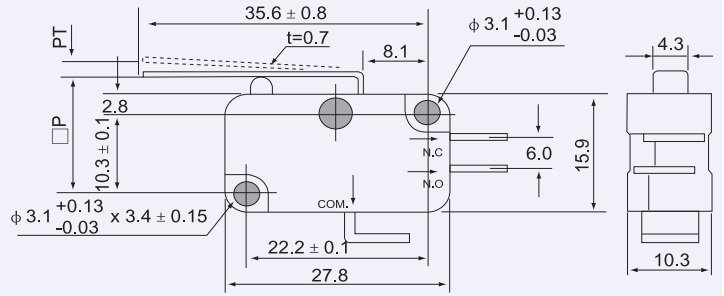
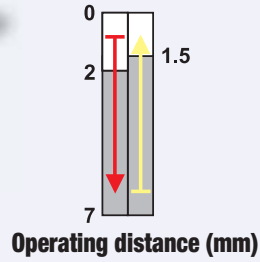

TRACON



<b>KW3-31</b>	6,3×0,8 mm
<b>KW3-35</b>	4,8×0,8 mm

Version with spring handle and roll

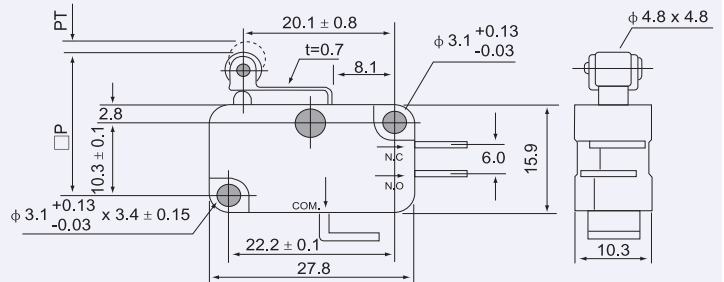
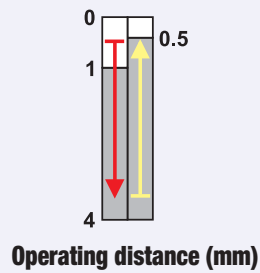

TRACON



<b>KW3-41</b>	6,3×0,8 mm
<b>KW3-45</b>	4,8×0,8 mm

Version with spring handle and roll

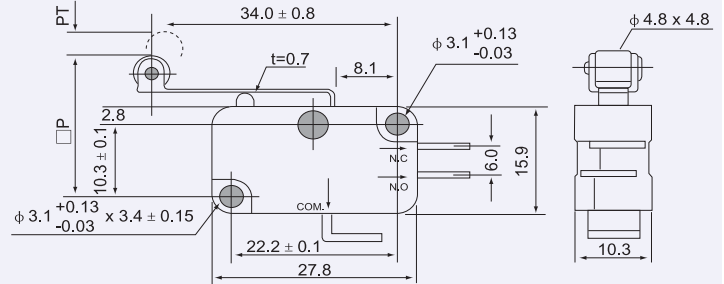
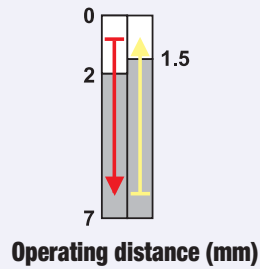

TRACON



<b>KW3-51</b>	6,3×0,8 mm
<b>KW3-55</b>	4,8×0,8 mm

Version with spring handle

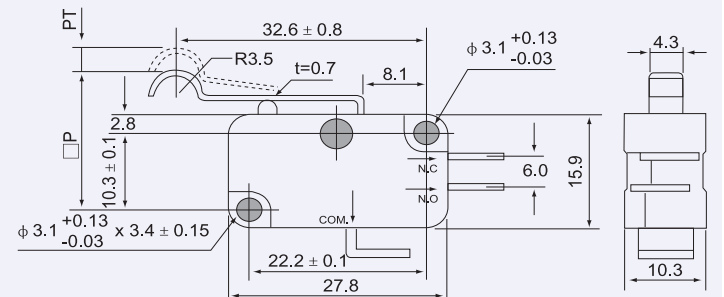
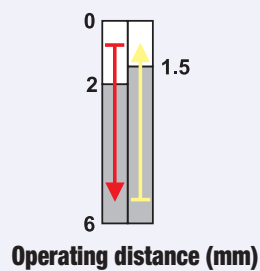

TRACON



<b>KW3-61</b>	6,3×0,8 mm
<b>KW3-65</b>	4,8×0,8 mm

Pushbuttons, switches and signal lamps

<b>I<sub>e</sub></b> (AC 1, 230 V) <b>6 A</b>	<b>I<sub>e</sub></b> (AC 15, 230 V) <b>3 A</b>	<b>I<sub>e</sub></b> (DC 13, 250 V) <b>0,27 A</b>	<b>U<sub>i</sub></b> <b>660 V</b>	<b>U<sub>imp</sub></b> <b>6 kV</b>	<b>[mm<sup>2</sup>]</b> <b>0,5-2,5</b>	<b>x10<sup>6</sup></b>	<b>F<sub>on</sub></b>   <b>max. 20 N</b>	<b>F<sub>off</sub></b> <b>max. 15 N</b>	<b>T<sub>a</sub></b> <b>-25..+70°C</b>	<b>IP 42</b>	<b>10 A gG</b>
--	---	--	--------------------------------------	---------------------------------------	---	------------------------	---	--	---	--------------	----------------



Principal drawing of contacts

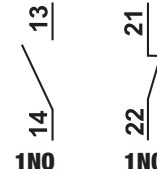

Pushbuttons, switches and signal lamps mounted on metal base

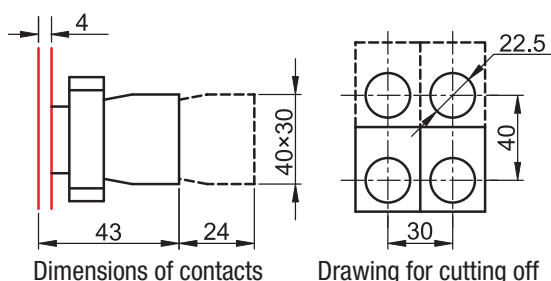

The devices can be fixed into Ø22 mm-size holes from inside with the 2 screws of the base. The number of the contact elements - to be fixed on the base - can be enlarged up to four, if needed. If elements in old control panels where the hole is Ø38 mm shall be changed, the new ones can be fixed by using reduction rings (NYGR38/22).

Enclosures

TRACON		W (mm)	H (mm)	x (mm)		IP..
TK/T1+F2/		68	64	44	2 x MG-20	IP 44
TK/T2+F2/		68	80	44	2 x MG-20	IP 44
TK/T1+F2S/		68	64	44	2 x MG-20	IP 44
TK/T2+F2S/		68	80	44	2 x MG-20	IP 44

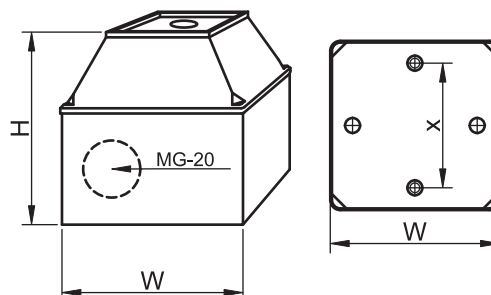

TÜV MEEI TEST DOCUMENTATION <b>V-15180</b>	RELEVANT STANDARD <b>EN 60529</b>
---	--------------------------------------

### Simple pushbuttons

$I_e$ (AC 1, 230 V) <b>6 A</b>	$I_e$ (AC 15, 230 V) <b>3 A</b>	$I_e$ (DC 13, 250 V) <b>0,27 A</b>	$U_i$ <b>660 V</b>	$[mm^2]$ <b>0,5-2,5</b>	$\times 10^6$	$F_{on}$   $F_{off}$ max. 20 N   max. 15 N	$T_a$ -25...+70°C	
-----------------------------------	------------------------------------	---------------------------------------	-----------------------	----------------------------	---------------	---	----------------------	--



**TRACON**

IP 42 + **IP44**

NC  
NO

<b>NYGBA21</b>	<b>NYGBA21T</b>		<b>TK/T1+F2/</b>	1 × NO
<b>NYGBA31Z</b>	<b>NYGBA31ZT</b>			1 × NO
<b>NYGBA51S</b>	<b>NYGBA51ST</b>			1 × NO
<b>NYGBA61K</b>	<b>NYGBA61KT</b>			1 × NO
<b>NYGBA42P</b>	<b>NYGBA42PT</b>			1 × NC

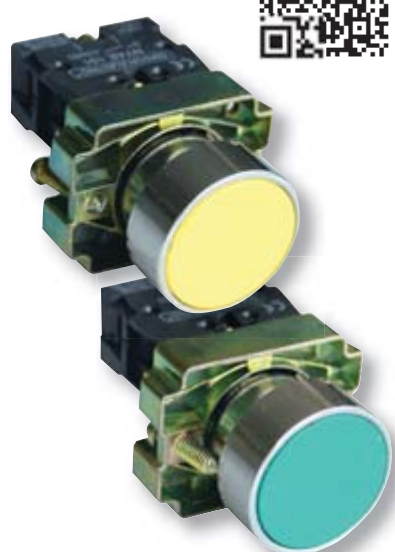
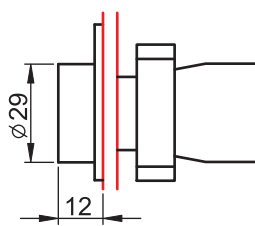

RELEVANT STANDARD  
**EN 60947-1**

RELEVANT STANDARD  
**EN 60947-5-1**

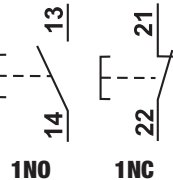

### Projecting pushbuttons

$I_e$ (AC 1, 230 V) <b>6 A</b>	$I_e$ (AC 15, 230 V) <b>3 A</b>	$I_e$ (DC 13, 250 V) <b>0,27 A</b>	$U_i$ <b>660 V</b>	$[mm^2]$ <b>0,5-2,5</b>	$\times 10^6$	$F_{on}$   $F_{off}$ max. 20 N   max. 15 N	$T_a$ -25...+70°C	
-----------------------------------	------------------------------------	---------------------------------------	-----------------------	----------------------------	---------------	---	----------------------	--



**TRACON**

IP 42 + **IP44**

NC  
NO

<b>NYGBL21</b>	<b>NYGBL21T</b>		<b>TK/T1+F2/</b>	1 × NO
<b>NYGBL31Z</b>	<b>NYGBL31ZT</b>			1 × NO
<b>NYGBL51S</b>	<b>NYGBL51ST</b>			1 × NO
<b>NYGBL61K</b>	<b>NYGBL61KT</b>			1 × NO
<b>NYGBL42P</b>	<b>NYGBL42PT</b>			1 × NC

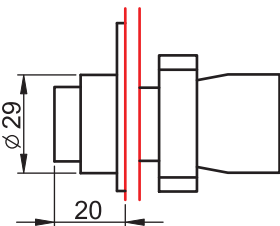

RELEVANT STANDARD  
**EN 60947-1**

RELEVANT STANDARD  
**EN 60947-5-1**

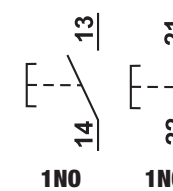

### Pushbuttons with rubber boot

$I_e$ (AC 1, 230 V) <b>6 A</b>	$I_e$ (AC 15, 230 V) <b>3 A</b>	$I_e$ (DC 13, 250 V) <b>0,27 A</b>	$U_i$ <b>660 V</b>	$[mm^2]$ <b>0,5-2,5</b>	$\times 10^6$	$F_{on}$   $F_{off}$ max. 20 N   max. 15 N	$T_a$ -25...+70°C	
-----------------------------------	------------------------------------	---------------------------------------	-----------------------	----------------------------	---------------	---	----------------------	--



**TRACON**

IP 42 + **IP44**

NC  
NO

<b>NYGBP21</b>	<b>NYGBP21T</b>		<b>TK/T1+F2/</b>	1 × NO
<b>NYGBP31Z</b>	<b>NYGBP31ZT</b>			1 × NO
<b>NYGBP51S</b>	<b>NYGBP51ST</b>			1 × NO
<b>NYGBP61K</b>	<b>NYGBP61KT</b>			1 × NO
<b>NYGBP42P</b>	<b>NYGBP42PT</b>			1 × NC

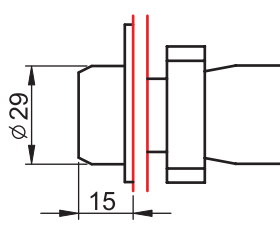

RELEVANT STANDARD  
**EN 60947-1**

RELEVANT STANDARD  
**EN 60947-5-1**

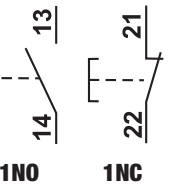



Pushbuttons with symbols

<b>I<sub>e</sub></b> (AC 1, 230 V) <b>6 A</b>	<b>I<sub>e</sub></b> (AC 15, 230 V) <b>3 A</b>	<b>I<sub>e</sub></b> (DC 13, 250 V) <b>0,27 A</b>	<b>U<sub>i</sub></b> <b>660 V</b>	<b>[mm<sup>2</sup>]</b> <b>0,5-2,5</b>	<b>⚒</b> <b>x10<sup>6</sup></b>	<b>F<sub>on</sub>  </b> <b>max. 20 N</b>	<b>  F<sub>off</sub></b> <b>max. 15 N</b>	<b>T<sub>a</sub></b> <b>-25...+70°C</b>				<b>K/O</b>
--	---	--	--------------------------------------	---	------------------------------------	---	--	--	--	--	--	------------

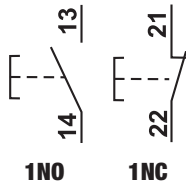

TRACON						
<b>NYGBA3351</b>	<b>NYGBA3351T</b>					1 × NO
<b>NYGBA3341</b>	<b>NYGBA3341T</b>					1 × NO
<b>NYGBA3311Z</b>	<b>NYGBA3311ZT</b>				<b>TK/T1+F2/</b>	1 × NO
<b>NYGBA4222P</b>	<b>NYGBA4222PT</b>					1 × NC
<b>NYGBA4322P*</b>	<b>NYGBA4322PT*</b>					1 × NC

\* Protruding versions

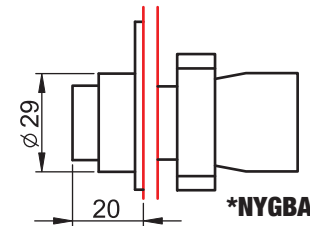
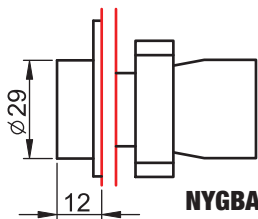

Pushbuttons with built-in signal light (Ba9s)

TRACON							<b>U<sub>m</sub></b>	
	<b>NYGBW33Z</b>	<b>NYGBW33ZT</b>				1 × NO	max. 400 V	NYGI230*
	<b>NYGBW33S</b>	<b>NYGBW33ST</b>			<b>TK/T2+F2/</b>	1 × NO	max. 400 V	NYGI230*
	<b>NYGBW33K</b>	<b>NYGBW33KT</b>				1 × NO	max. 400 V	NYGI230*
	<b>NYGBW33P</b>	<b>NYGBW33PT</b>				1 × NC	max. 400 V	NYGI230*
	<b>NYGBW3371Z</b>	<b>NYGBW3371ZT</b>				1 × NO	230-240 V	NYGI130**
	<b>NYGBW3571S</b>	<b>NYGBW3571ST</b>			<b>TK/T2+F2/</b>	1 × NO	230-240 V	NYGI130**
	<b>NYGBW3471P</b>	<b>NYGBW3471PT</b>				1 × NC	230-240 V	NYGI130**
	<b>NYGBW3341Z</b>	-				1 × NO	230-240 V	NYGI6**
	<b>NYGBW3541S</b>	-				1 × NO	230-240 V	NYGI6**
	<b>NYGBW3441P</b>	-				1 × NC	230-240 V	NYGI6**
	<b>NYGBW3351Z</b>	-			-	1 × NO	400 V	NYGI6**
	<b>NYGBW3551S</b>	-				1 × NO	400 V	NYGI6**
	<b>NYGBW3451P</b>	-				1 × NC	400 V	NYGI6**

\* The applicable bulb should be selected in accordance to the operating voltage!

\*\* Signal lamps with ballast are operated under 130 V, by versions with transformer the operating voltage is 6 V.



Normal

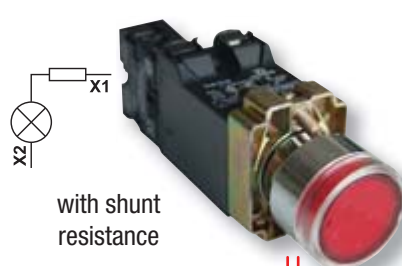
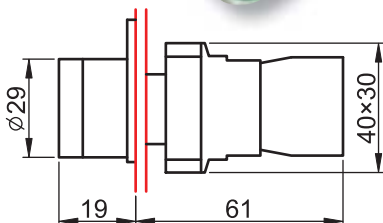

with shunt resistance

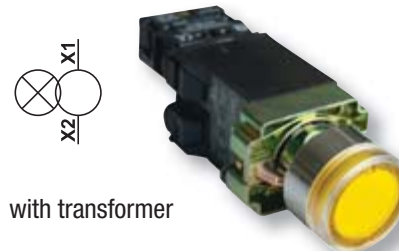
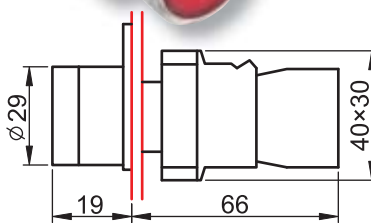

with transformer

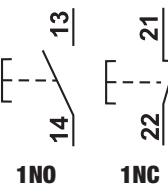
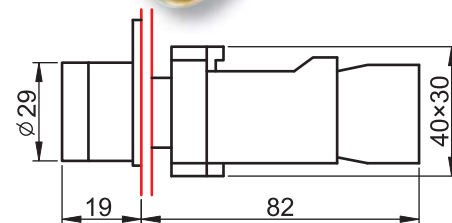

### Pushbuttons with mushroom head

<b>I<sub>e</sub></b> (AC 1, 230 V) <b>6 A</b>	<b>I<sub>e</sub></b> (AC 15, 230 V) <b>3 A</b>	<b>I<sub>e</sub></b> (DC 13, 250 V) <b>0,27 A</b>	<b>U<sub>i</sub></b> <b>660 V</b>	<b>[mm<sup>2</sup>]</b> <b>0,5-2,5</b>	<b>×10<sup>6</sup></b>	<b>F<sub>on</sub></b> <b>max. 20 N</b>	<b>F<sub>off</sub></b> <b>max. 15 N</b>	<b>T<sub>a</sub></b> <b>-25...+70°C</b>		<b>Pictograms</b>	<b>K/O</b>
--	---	--	--------------------------------------	---	------------------------	---	--	--	--	-------------------	------------

TRACON										
<b>NYGBC21</b>	<b>NYGBC21T</b>	-						1 × NO	40 mm	
<b>NYGBC31Z</b>	<b>NYGBC31ZT</b>	-					TK/T1+F2/	1 × NO		
<b>NYGBC51S</b>	<b>NYGBC51ST</b>	-						1 × NO		
<b>NYGBC61K</b>	<b>NYGBC61KT</b>	-						1 × NO		
<b>NYGBC42P</b>	<b>NYGBC42PT</b>	<b>NYGBC42PTS</b>						TK/T1+F2S/	1 × NC	
<b>NYGBR42P</b>	<b>NYGBR42PT</b>	<b>NYGBR42PTS</b>							1 × NC	60 mm

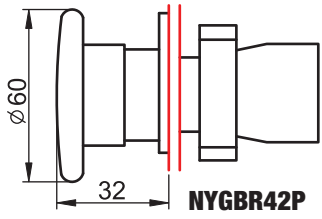
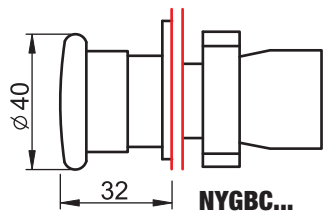
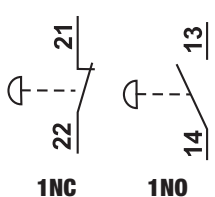

RELEVANT STANDARD  
**EN 60947-1**

RELEVANT STANDARD  
**EN 60947-5-1**



### Emergency pushbuttons with mushroom head

<b>I<sub>e</sub></b> (AC 1, 230 V) <b>6 A</b>	<b>I<sub>e</sub></b> (AC 15, 230 V) <b>3 A</b>	<b>I<sub>e</sub></b> (DC 13, 250 V) <b>0,27 A</b>	<b>U<sub>i</sub></b> <b>660 V</b>	<b>[mm<sup>2</sup>]</b> <b>0,5-2,5</b>	<b>×10<sup>6</sup></b>	<b>F<sub>on</sub></b> <b>max. 20 N</b>	<b>F<sub>off</sub></b> <b>max. 15 N</b>	<b>T<sub>a</sub></b> <b>-25...+70°C</b>		<b>Pictograms</b>	<b>K/O</b>
--	---	--	--------------------------------------	---	------------------------	---	--	--	--	-------------------	------------

TRACON											
<b>NYG442P30</b>	<b>NYG442P30T</b>	<b>NYG442P30TS</b>						1 × NC	30 mm		
<b>NYG542P40</b>	<b>NYG542P40T</b>	<b>NYG542P40TS</b>						1 × NC	40 mm		
<b>NYG642P60</b>	<b>NYG642P60T</b>	<b>NYG642P60TS</b>					TK/T1+F2/	1 × NC	60 mm		
<b>NYGBS8445P</b>	<b>NYGBS8445PT</b>	<b>NYGBS8445PTS</b>						TK/T1+F2S/	1 × NC+1 × NO	40 mm	
<b>NYGBS142P</b>	<b>NYGBS142PT</b>	<b>NYGBS142PTS</b>							1 × NC	40 mm	
<b>NYGBS9445P</b>	<b>NYGBS9445PT</b>	<b>NYGBS9445PTS</b>							1 × NC+1 × NO	40 mm	

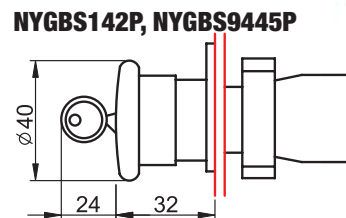
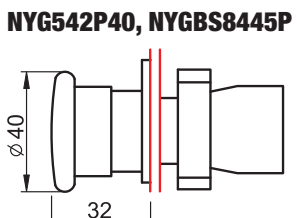
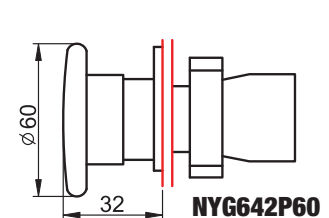
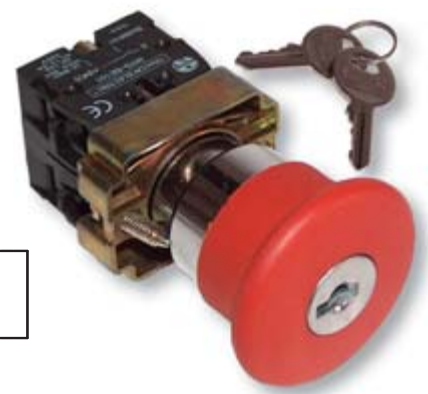
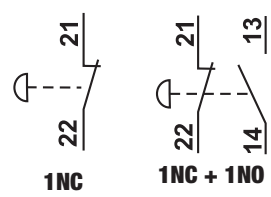
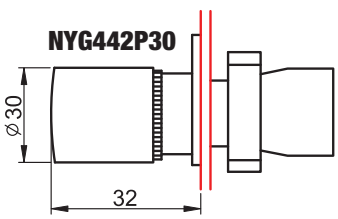

Double on-off pushbuttons

$I_e$ (AC 1, 230 V) <b>6 A</b>	$I_e$ (AC 15, 230 V) <b>3 A</b>	$I_e$ (DC 13, 250 V) <b>0,27 A</b>	$U_i$ <b>660 V</b>	$[mm^2]$ <b>0,5-2,5</b>	$\times 10^6$	$F_{on}$   $F_{off}$ <b>max. 20 N</b> / <b>max. 15 N</b>	$T_a$ <b>-25...+70°C</b>			<b>Pictograms</b>	<b>K/0</b>
-----------------------------------	------------------------------------	---------------------------------------	-----------------------	----------------------------	---------------	---	-----------------------------	--	--	-------------------	------------



TRACON											
<b>NYKK8325</b>	<b>NYKK8325T</b>										
<b>NYKK8425</b>	<b>NYKK8425T</b>										

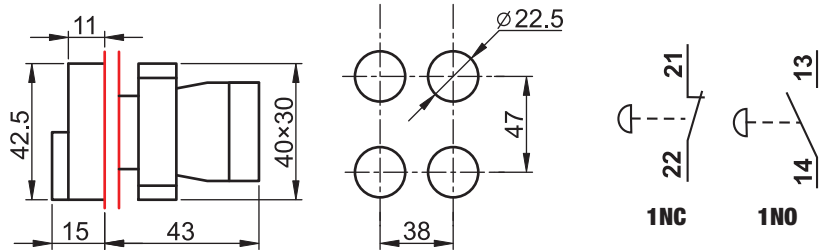

Double, on-off pushbuttons with pilot light (Ba9s)

$I_e$ (AC 1, 230 V) <b>6 A</b>	$I_e$ (AC 15, 230 V) <b>3 A</b>	$I_e$ (DC 13, 250 V) <b>0,27 A</b>	$U_i$ <b>660 V</b>	$[mm^2]$ <b>0,5-2,5</b>	$\times 10^6$	$F_{on}$   $F_{off}$ <b>max. 20 N</b> / <b>max. 15 N</b>	$T_a$ <b>-25...+70°C</b>	
-----------------------------------	------------------------------------	---------------------------------------	-----------------------	----------------------------	---------------	---	-----------------------------	--

TRACON								
	<b>NYKK8365</b>	<b>I</b>		<b>0</b>	<b>1 × NC+1 × NO</b>	<b>max. 400 V</b>	<b>NYGI230*</b>	
	<b>NYKK8465</b>	<b>I</b>		<b>0</b>	<b>1 × NC+1 × NO</b>	<b>max. 400 V</b>	<b>NYGI230*</b>	
	<b>NYKK8375</b>	<b>I</b>		<b>0</b>	<b>1 × NC+1 × NO</b>	<b>240 V</b>	<b>NYGI130**</b>	
	<b>NYKK8475</b>	<b>I</b>		<b>0*</b>	<b>1 × NC+1 × NO</b>	<b>240 V</b>	<b>NYGI130**</b>	

\* The applicable bulb should be selected in accordance to the operating voltage!

\*\* Signal lamps with ballast are operated under 130 V.

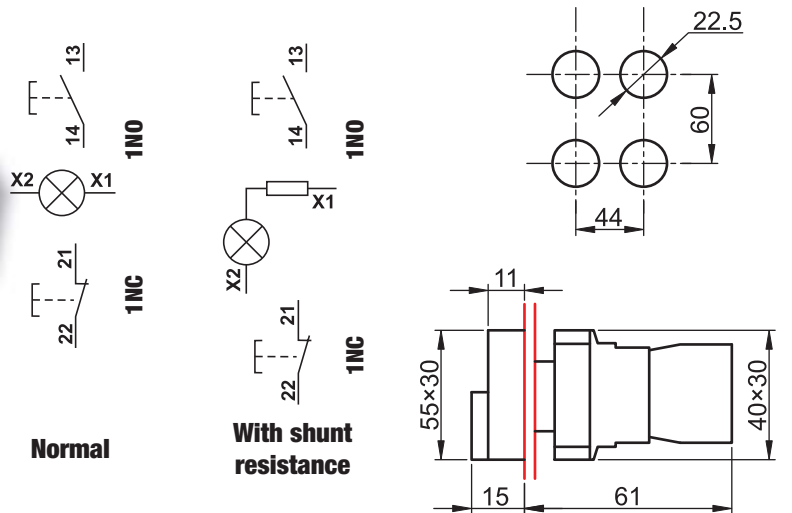
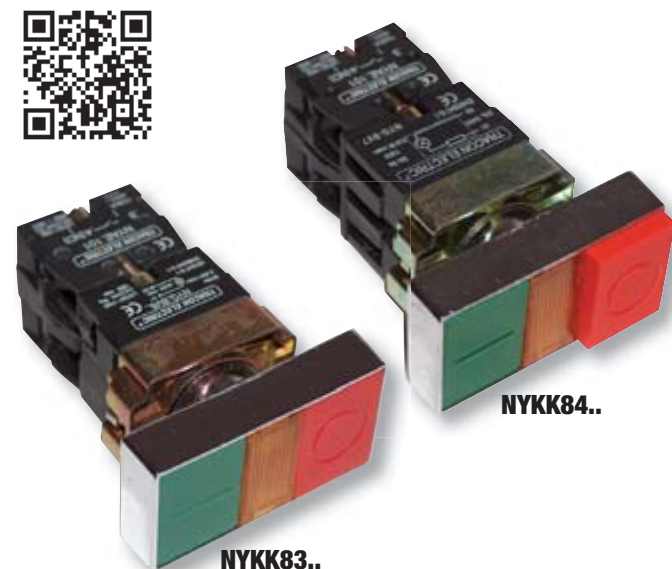

### Signal lamps (Ba9s)

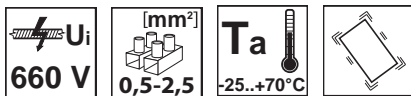

TRACON				U <sub>m</sub>	IP44	
IP 42		+	IP44			
	<b>NYGBV61</b>	<b>NYGBV61T</b>		max. 400 V	TK/T1+F2/	NYGI230*
	<b>NYGBV63Z</b>	<b>NYGBV63ZT</b>		max. 400 V		NYGI230*
	<b>NYGBV64P</b>	<b>NYGBV64PT</b>		max. 400 V		NYGI230*
	<b>NYGBV65S</b>	<b>NYGBV65ST</b>		max. 400 V		NYGI230*
	<b>NYGBV66K</b>	<b>NYGBV66KT</b>		max. 400 V		NYGI230*
	<b>NYGBV73Z</b>	<b>NYGBV73ZT</b>		230-240 V		NYGI130**
	<b>NYGBV74P</b>	<b>NYGBV74PT</b>		230-240 V		NYGI130**
	<b>NYGBV75S</b>	<b>NYGBV75ST</b>		230-240 V		NYGI130**
	<b>NYGBV43Z</b>	<b>NYGBV43ZT</b>		230-240 V		NYGI6**
	<b>NYGBV44P</b>	<b>NYGBV44PT</b>		230-240 V		NYGI6**
	<b>NYGBV45S</b>	<b>NYGBV45ST</b>		230-240 V	TK/T2+F2/	NYGI6**
	<b>NYGBV53Z</b>	<b>NYGBV53ZT</b>		400 V	NYGI6**	
	<b>NYGBV54P</b>	<b>NYGBV54PT</b>		400 V	NYGI6**	
	<b>NYGBV55S</b>	<b>NYGBV55ST</b>		400 V	NYGI6**	

\* The applicable bulb should be selected in accordance to the operating voltage!

\*\* Signal lamps with ballast are operated under 130 V, by versions with transformer the operating voltage is 6 V.

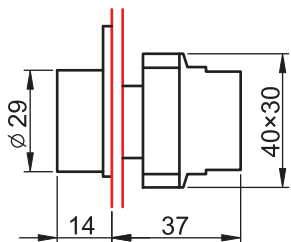

Normal

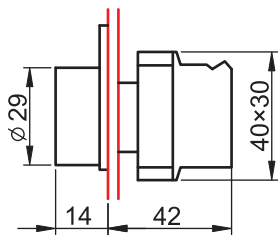

With shunt resistance

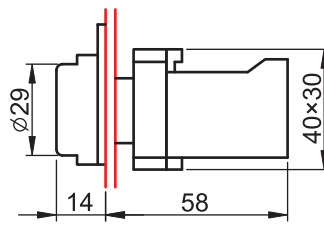
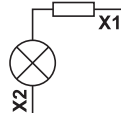

With transformer

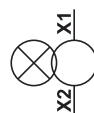

TÜV MEEI TEST DOCUMENTATION  
**V-15180**

RELEVANT STANDARD  
**EN 62094**





Selector switches

<b>I<sub>e</sub></b> (AC 1, 230 V) <b>6 A</b>	<b>I<sub>e</sub></b> (AC 15, 230 V) <b>3 A</b>	<b>I<sub>e</sub></b> (DC 13, 250 V) <b>0,27 A</b>	<b>U<sub>i</sub></b> <b>660 V</b>	<b>[mm<sup>2</sup>]</b> <b>0,5-2,5</b>	<b>×10<sup>6</sup></b>	<b>F<sub>on</sub>  </b> <b>max. 20 N</b>	<b>  F<sub>off</sub></b> <b>max. 15 N</b>	<b>T<sub>a</sub></b> <b>-25...+70°C</b>	
--	---	--	--------------------------------------	---	------------------------	---	--	--	--

TRACON			IP 42	IP 44	NC	NO	L
Normal	<b>NYBD21KST</b>	<b>NYBD21KSTT</b>	1 <sup>1</sup> 2	1 × NO	29 mm		
	<b>NYBJ21KLO</b>	<b>NYBJ21KLOT</b>	1 <sup>1</sup> 2	1 × NO	39 mm		
	<b>KBD25ST</b>	<b>KBD25STT</b>	1 <sup>1</sup> 2	1 × NC+1 × NO	29 mm		
	<b>KBJ25LO</b>	<b>KBJ25LOT</b>	1 <sup>1</sup> 2	1 × NC+1 × NO	39 mm		
	<b>NYBD33KST</b>	<b>NYBD33KSTT</b>	1 <sup>1,0,2</sup>	2 × NO	29 mm		
	<b>NYBJ33KLO</b>	<b>NYBJ33KLOT</b>	1 <sup>1,0,2</sup>	2 × NO	39 mm		
With spring return	<b>NYBD41KST</b>	<b>NYBD41KSTT</b>	1 <sup>1</sup> 2	1 × NO	29 mm		
	<b>NYBJ41KLO</b>	<b>NYBJ41KLOT</b>	1 <sup>1</sup> 2	1 × NO	39 mm		
	<b>NYBD45KST</b>	<b>NYBD45KSTT</b>	1 <sup>1</sup> 2	1 × NC+1 × NO	29 mm		
	<b>NYBJ45KLO</b>	<b>NYBJ45KLOT</b>	1 <sup>1</sup> 2	1 × NC+1 × NO	39 mm		
	<b>NYBD53KST</b>	<b>NYBD53KSTT</b>	1 <sup>1,0,2</sup>	2 × NO	29 mm		
	<b>NYBJ53KLO</b>	<b>NYBJ53KLOT</b>	1 <sup>1,0,2</sup>	2 × NO	39 mm		

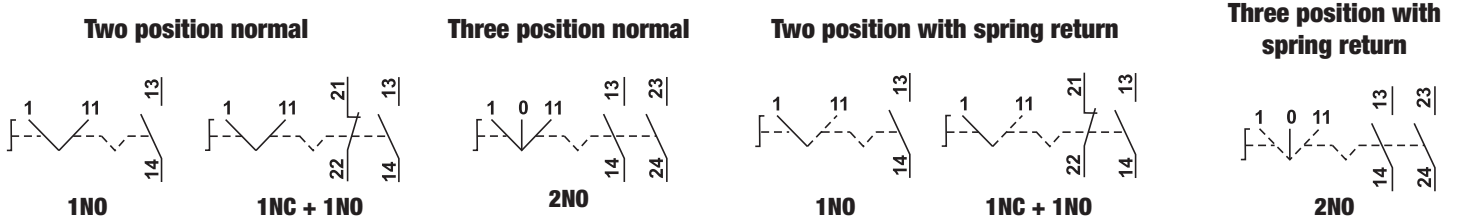
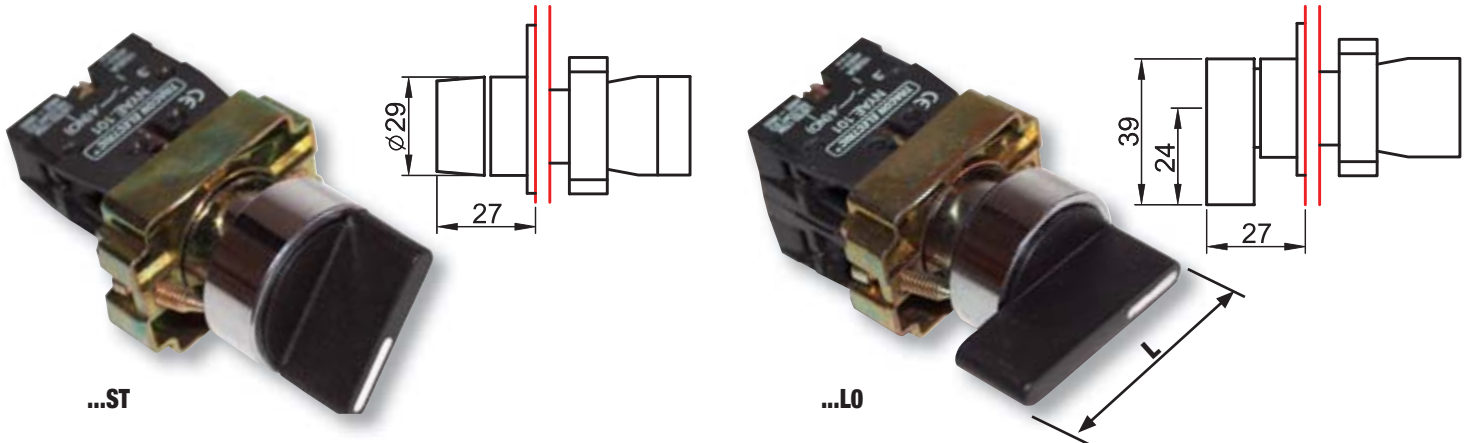

### Key switches

$I_e$ (AC 1, 230 V) <b>6 A</b>	$I_e$ (AC 15, 230 V) <b>3 A</b>	$I_e$ (DC 13, 250 V) <b>0,27 A</b>	$U_i$ <b>660 V</b>	[mm <sup>2</sup> ] <b>0,5-2,5</b>	$\times 10^6$	$F_{on}$ max. 20 N	$F_{off}$ max. 15 N	$T_a$ -25..+70°C	
-----------------------------------	------------------------------------	---------------------------------------	-----------------------	--------------------------------------	---------------	-----------------------	------------------------	---------------------	--



**TRACON**

IP 42 + IP44

NC  
 NO

Normal	<b>NYBG21KK</b>	<b>NYBG21KKT</b>	$\downarrow \begin{smallmatrix} 1 \\ 2 \end{smallmatrix}$	1 × NO	$\begin{smallmatrix} 1 \\ 2 \end{smallmatrix}$
	<b>NYBG41KK</b>	<b>NYBG41KKT</b>	$\downarrow \begin{smallmatrix} 1 \\ 2 \end{smallmatrix}$	1 × NO	$\begin{smallmatrix} 1 \\ 2 \end{smallmatrix}$
	<b>NYBG25KK</b>	<b>NYBG25KKT</b>	$\downarrow \begin{smallmatrix} 1 \\ 2 \end{smallmatrix}$	1 × NC+1 × NO	$\begin{smallmatrix} 1 \\ 2 \end{smallmatrix}$
With spring return	<b>NYBG53KK</b>	<b>NYBG53KKT</b>	$\downarrow \begin{smallmatrix} 1, 0, 2 \end{smallmatrix}$	2 × NO	$\begin{smallmatrix} 1, 0, 2 \\ 1, 0, 2 \end{smallmatrix}$
	<b>NYBG61KK</b>	<b>NYBG61KKT</b>	$\downarrow \begin{smallmatrix} 1 \\ 2 \end{smallmatrix}$	1 × NO	$\begin{smallmatrix} 1 \\ 2 \end{smallmatrix}$
	<b>NYBG65KK</b>	<b>NYBG65KKT</b>	$\downarrow \begin{smallmatrix} 1 \\ 2 \end{smallmatrix}$	1 × NC+1 × NO	$\begin{smallmatrix} 1 \\ 2 \end{smallmatrix}$
	<b>NYBG73KK</b>	<b>NYBG73KKT</b>	$\downarrow \begin{smallmatrix} 1, 0, 2 \end{smallmatrix}$	2 × NO	$\begin{smallmatrix} 1, 0, 2 \\ 1, 0, 2 \end{smallmatrix}$

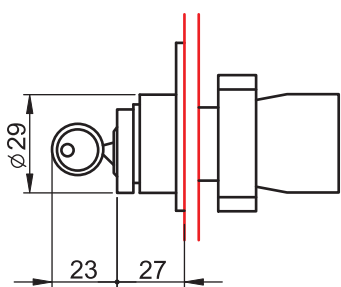

Two position normal

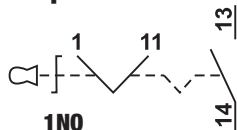

Two position normal

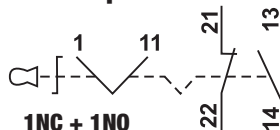

Three position normal

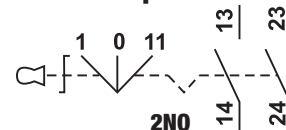

Two position with spring return

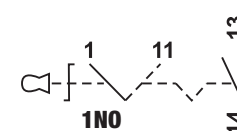

Two position with spring return

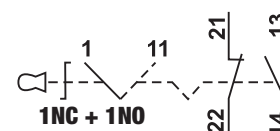

Three position with spring return

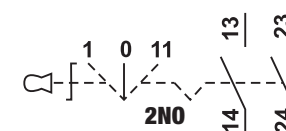

### Selector switches with built-in signal light (Ba9s)

$I_e$ (AC 1, 230 V) <b>6 A</b>	$I_e$ (AC 15, 230 V) <b>3 A</b>	$I_e$ (DC 13, 250 V) <b>0,27 A</b>	$U_i$ <b>660 V</b>	[mm <sup>2</sup> ] <b>0,5-2,5</b>	$\times 10^6$	$F_{on}$ max. 20 N	$F_{off}$ max. 15 N	$T_a$ -25..+70°C		$U_m$ max. 400 V
-----------------------------------	------------------------------------	---------------------------------------	-----------------------	--------------------------------------	---------------	-----------------------	------------------------	---------------------	--	---------------------



**TRACON**

IP 42 + IP44

NC  
 NO

Normal	<b>NYGBK2365Z</b>	<b>NYGBK2365ZT</b>	$\downarrow \begin{smallmatrix} 1 \\ 2 \end{smallmatrix}$		1 × NC+1 × NO	NYGLZ
	<b>NYGBK2565S</b>	<b>NYGBK2565ST</b>	$\downarrow \begin{smallmatrix} 1 \\ 2 \end{smallmatrix}$		1 × NC+1 × NO	NYGLS
	<b>NYGBK2665K</b>	<b>NYGBK2665KT</b>	$\downarrow \begin{smallmatrix} 1 \\ 2 \end{smallmatrix}$		1 × NC+1 × NO	NYGLK
	<b>NYGBK2465P</b>	<b>NYGBK2465PT</b>	$\downarrow \begin{smallmatrix} 1 \\ 2 \end{smallmatrix}$		1 × NC+1 × NO	NYGLP
	<b>NYGBK3365Z</b>	<b>NYGBK3365ZT</b>	$\downarrow \begin{smallmatrix} 1, 0, 2 \end{smallmatrix}$		1 × NC+1 × NO	NYGLZ
	<b>NYGBK3565S</b>	<b>NYGBK3565ST</b>	$\downarrow \begin{smallmatrix} 1, 0, 2 \end{smallmatrix}$		1 × NC+1 × NO	NYGLS
	<b>NYGBK3665K</b>	<b>NYGBK3665KT</b>	$\downarrow \begin{smallmatrix} 1, 0, 2 \end{smallmatrix}$		1 × NC+1 × NO	NYGLK
With spring return	<b>NYGBK3465P</b>	<b>NYGBK3465PT</b>	$\downarrow \begin{smallmatrix} 1, 0, 2 \end{smallmatrix}$		1 × NC+1 × NO	NYGLP
	<b>NYGBK5365Z</b>	<b>NYGBK5365ZT</b>	$\downarrow \begin{smallmatrix} 1 \\ 2 \end{smallmatrix}$		1 × NC+1 × NO	NYGLZ
	<b>NYGBK5565S</b>	<b>NYGBK5565ST</b>	$\downarrow \begin{smallmatrix} 1 \\ 2 \end{smallmatrix}$		1 × NC+1 × NO	NYGLS
	<b>NYGBK5665K</b>	<b>NYGBK5665KT</b>	$\downarrow \begin{smallmatrix} 1 \\ 2 \end{smallmatrix}$		1 × NC+1 × NO	NYGLK
	<b>NYGBK5465P</b>	<b>NYGBK5465PT</b>	$\downarrow \begin{smallmatrix} 1 \\ 2 \end{smallmatrix}$		1 × NC+1 × NO	NYGLP



Three position with spring return

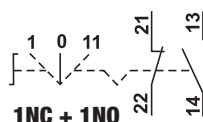

Two position normal

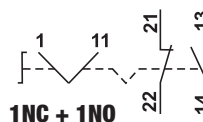

Three position normal

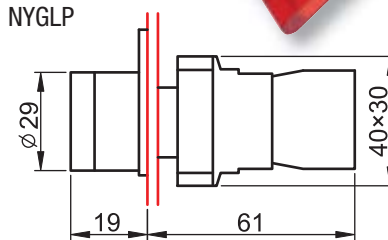
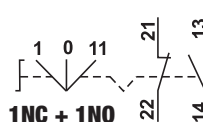

Pushbuttons, switches and signal lamps with plastic body

<b>I<sub>e</sub></b> (AC 1, 230 V) <b>6 A</b>	<b>I<sub>e</sub></b> (AC 15, 230 V) <b>3 A</b>	<b>I<sub>e</sub></b> (DC 12, 230 V) <b>0,4 A</b>	<b>U<sub>i</sub></b> <b>660 V</b>	<b>[mm<sup>2</sup>]</b> <b>0,5-2,5</b>	<b>×10<sup>6</sup></b>	<b>F<sub>on</sub></b>   <b>max. 20 N</b>	<b>F<sub>off</sub></b> <b>max. 15 N</b>	<b>T<sub>a</sub></b> <b>-25...+70°C</b>		<b>Pictograms</b>	<b>K/O</b>
--	---	---	--------------------------------------	---	------------------------	---	--	--	--	-------------------	------------

TRACON						
<b>NYGEA121</b>	<b>NYGEA121T</b>				<b>TK/T1+F2/</b>	1 × NO
<b>NYGEA131Z</b>	<b>NYGEA131ZT</b>					1 × NO
<b>NYGEA151S</b>	<b>NYGEA151ST</b>					1 × NO
<b>NYGEA161K</b>	<b>NYGEA161KT</b>					1 × NO
<b>NYGEA142P</b>	<b>NYGEA142PT</b>					1 × NC
<b>NYGEA125</b>	<b>NYGEA125T</b>					1 × CO
<b>NYGEA135Z</b>	<b>NYGEA135ZT</b>					1 × CO
<b>NYGEA145P</b>	<b>NYGEA145PT</b>					1 × CO

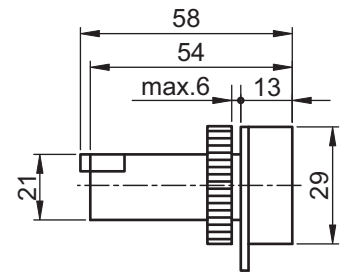
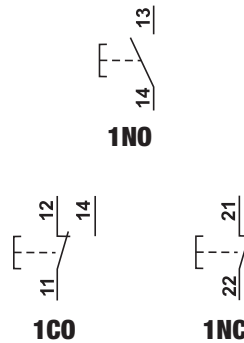

Pushing switches

<b>I<sub>e</sub></b> (AC 1, 230 V) <b>6 A</b>	<b>I<sub>e</sub></b> (AC 15, 230 V) <b>3 A</b>	<b>I<sub>e</sub></b> (DC 12, 230 V) <b>0,4 A</b>	<b>U<sub>i</sub></b> <b>660 V</b>	<b>[mm<sup>2</sup>]</b> <b>0,5-2,5</b>	<b>×10<sup>6</sup></b>	<b>F<sub>on</sub></b>   <b>max. 20 N</b>	<b>F<sub>off</sub></b> <b>max. 15 N</b>	<b>T<sub>a</sub></b> <b>-25...+70°C</b>	
--	---	---	--------------------------------------	---	------------------------	---	--	--	--

TRACON						
<b>NYGEH121</b>	<b>NYGEH121T</b>				<b>TK/T1+F2/</b>	1 × NO
<b>NYGEH131Z</b>	<b>NYGEH131ZT</b>					1 × NO
<b>NYGEH142P</b>	<b>NYGEH142PT</b>					1 × NC
<b>NYGEH125F</b>	<b>NYGEH125FT</b>					1 × CO
<b>NYGEH135Z</b>	<b>NYGEH135ZT</b>					1 × CO
<b>NYGEH145P</b>	<b>NYGEH145PT</b>					1 × CO
<b>NYGEH155S</b>	<b>NYGEH155ST</b>					1 × CO
<b>NYGEH165K</b>	<b>NYGEH165KT</b>					1 × CO

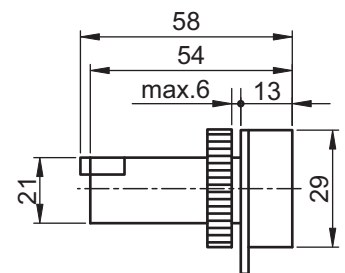
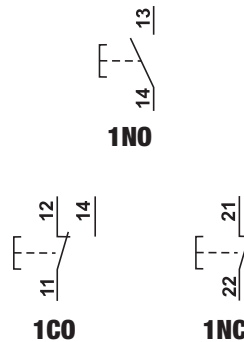

### Signal lamps (Ba9s)

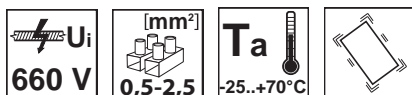

TRACON			Um	IP44		
IP 42		IP44				
	NYGEV133Z	NYGEV133ZT	max. 130 V	TK/T1+F2/	NYGI130*	
	NYGEV134P	NYGEV134PT	max. 130 V		NYGI130*	
	NYGEV163Z	NYGEV163ZT	max. 250 V		-*	
	NYGEV164P	NYGEV164PT	max. 250 V		-*	
	NYGEV165S	NYGEV165ST	max. 250 V		-*	
	NYGEV166K	NYGEV166KT	max. 250 V		-*	
	NYGEV443Z	NYGEV443ZT	max. 250 V		NYGI230*	
	NYGEV444P	NYGEV444PT	max. 250 V		NYGI230*	
	NYGEV445S	NYGEV445ST	max. 250 V		NYGI230*	
	NYGEV446K	NYGEV446KT	max. 250 V		NYGI230*	
	NYGEV453Z	NYGEV453ZT	max. 400 V		NYGI230*	
	NYGEV454P	NYGEV454PT	max. 400 V		NYGI230*	
	NYGEV455S	NYGEV455ST	max. 400 V		NYGI230*	
	NYGEV456K	NYGEV456KT	max. 400 V		NYGI230*	
	NYGEV173Z	NYGEV173ZT	230-240 V		TK/T1+F2/	NYGI130**
	NYGEV174P	NYGEV174PT	230-240 V			NYGI130**
	NYGEV175S	NYGEV175ST	230-240 V	NYGI130**		
	NYGEV176K	NYGEV176KT	230-240 V	NYGI130**		
	NYLBV853Z	-	230-240 V	-	NYGI6**	
	NYLBV854P	-	230-240 V		NYGI6**	
	NYLBV855S	-	230-240 V		NYGI6**	
	NYLBV856K	-	230-240 V		NYGI6**	
	NYLBV873Z	-	400 V		NYGI6**	
	NYLBV874P	-	400 V		NYGI6**	
	NYLBV875S	-	400 V		NYGI6**	
	NYLBV876K	-	400 V		NYGI6**	

\* The applicable bulb should be selected in accordance to the operating voltage!

\*\* Signal lamps with ballast are operated under 130 V, by versions with transformer the operating voltage is 6 V.



Normal

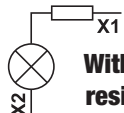

With shunt resistance

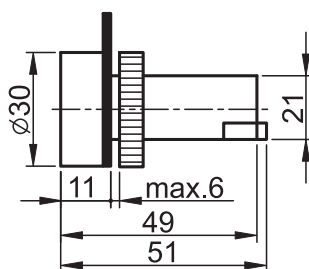

RELEVANT STANDARD  
EN 62094

RELEVANT STANDARD  
EN 60947-5-1

With transformer

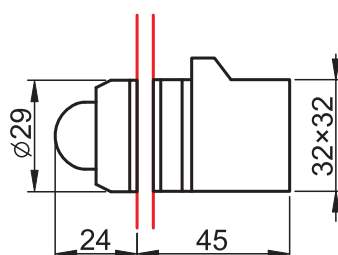
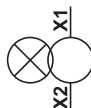



Normal signal bulbs



TRACON	U <sub>m</sub>		
NYGI6	6 V AC/DC	1,2 W	Ba9s
NYGI12	12 V AC/DC	2 W	Ba9s
NYGI24	24 V AC/DC	2 W	Ba9s
NYGI48	48 V AC/DC	2 W	Ba9s
NYGI130	130 V AC/DC	2,6 W	Ba9s
NYGI230	230 V AC	glimm	Ba9s

LED signal bulbs



TRACON	U <sub>m</sub>		
NYGLS	110-230 V		Ba9s
NYGLP	110-230 V		Ba9s
NYGLK	110-230 V		Ba9s
NYGLF	110-230 V		Ba9s
NYGLZ	110-230 V		Ba9s

LED signal bulbs (new version)



TRACON	U <sub>m</sub>		
NYGL-AC400B	400 V AC		Ba9s
NYGL-AC400G	400 V AC		Ba9s
NYGL-AC400R	400 V AC		Ba9s
NYGL-AC400W	400 V AC		Ba9s
NYGL-AC400Y	400 V AC		Ba9s
NYGL-ACDC230B	230 V AC/DC		Ba9s
NYGL-ACDC230G	230 V AC/DC		Ba9s
NYGL-ACDC230R	230 V AC/DC		Ba9s
NYGL-ACDC230W	230 V AC/DC		Ba9s
NYGL-ACDC230Y	230 V AC/DC		Ba9s
NYGL-ACDC24B	24 V AC/DC		Ba9s
NYGL-ACDC24G	24 V AC/DC		Ba9s
NYGL-ACDC24R	24 V AC/DC		Ba9s
NYGL-ACDC24W	24 V AC/DC		Ba9s
NYGL-ACDC24Y	24 V AC/DC		Ba9s

Contact elements



3 — 4 (NO)  
NYAE101

1 — 2 (NC)  
NYAE102



TRACON		
NYAE101	1 × NO	
NYAE102	1 × NC	

If necessary, a maximum number of four contact elements can be fixed to the base unit.

Reduction rings



TRACON	
--------	--

**NYGR30/22** Reduction rings from D=30 mm to d=22 mm (pairs)

**NYGR38/22** Reduction rings from D=38 mm to d=22 mm (pairs)

If control devices shall be replaced in older type distribution boards with Ø38 mm holes, reduction rings can be intercalated for proper fixation to the board.



# Relay safety switches

<b>250</b> V AC	50/60 Hz	<b>I<sub>e</sub></b> (AC 3, 250 V) <b>15 A</b>	<b>T<sub>a</sub></b> -25...+80°C	% rH max. 95	<b>IP</b> <b>55</b>
--------------------	----------	---	-------------------------------------	-----------------	------------------------



The SSTM type switches are appropriate for safe ON/OFF switching of various machine tools or electric devices, as they ensure automatic protection against unwanted start, when power supply returns after a network failure. The switches are meant for installation in boxes. Once built in, the operating button face affords IP 55 degree of protection, i.e. the switches can be used in dusty and/or wet environment. Wire connection is made with quick connecting terminals, 6.3 × 0.8 mm.

The switches are of two-poles type, with two closing contacts. The pushbuttons are of spring-return type, independently operated.

The power failure relay is factory built-in, without own output contacts, the operating voltage is ensured by the load-side contacts of the switch. In case of power failure, the relay disconnects the controlled device from the power supply line. Re-start is only possible with repeated operation of the green (I) pushbutton, by the user.

The SSTM-01 version is equipped with a special cover, functioning like an emergency button. Upon being actuated, it produces a locked stop.

The device can only be re-started after repair of the fault, by lifting the cover and thus resetting the error condition.

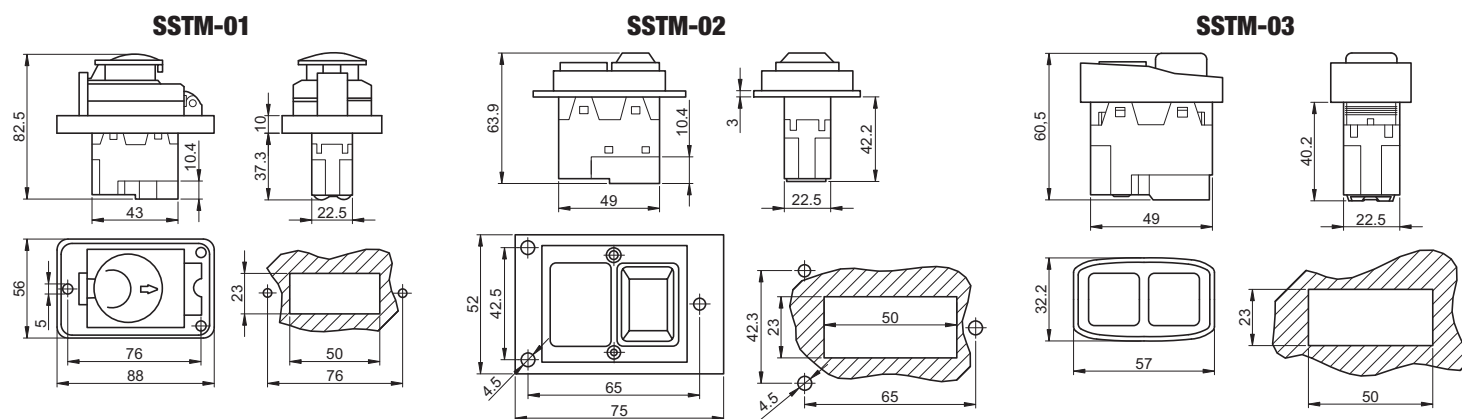

**SSTM-04**

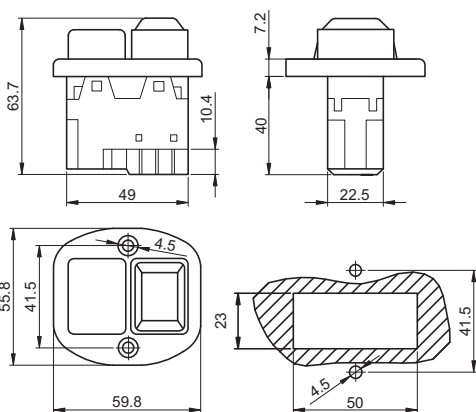

Load

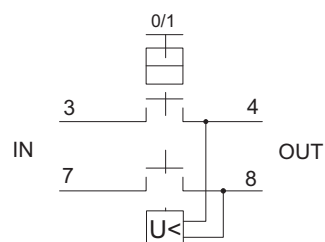

**NYG2 Pushbutton product family**

<b>I<sub>e</sub></b> (AC 1, 230 V) <b>6 A</b>	<b>I<sub>e</sub></b> (AC 15, 230 V) <b>3 A</b>	<b>I<sub>e</sub></b> (DC 13, 250 V) <b>0,27 A</b>	<b>U<sub>i</sub></b> <b>600 V</b>	<b>U<sub>imp</sub></b> <b>6 kV</b>	<b>[mm<sup>2</sup>]</b> <b>0,5-2,5</b>	<b>⚡</b> <b>x10<sup>6</sup></b>	<b>F<sub>on</sub></b> <b>max. 20 N</b>	<b>F<sub>off</sub></b> <b>max. 15 N</b>	<b>T<sub>a</sub></b> <b>-25..+70°C</b>	<b>IP 42</b>	<b>10 A gG</b>
--	---	--	--------------------------------------	---------------------------------------	---	------------------------------------	---	--	---	--------------	----------------



Scheme of contacts

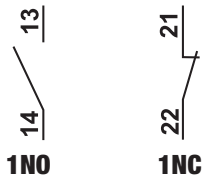

RELEVANT STANDARD  
**EN 60947-1**

RELEVANT STANDARD  
**EN 60947-5-1**

Drawing for cutting off

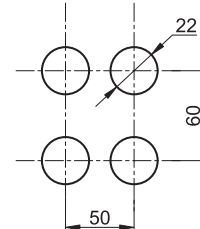

**Performance**



The units can be chosen from 4 groups:

- 1** - head units (1)
- 2** - bases (2)
- 3** - light (LED) units (3)
- 4** - contact units (4)

The primary unit of pushbutton is the base (**NYG2-T**); it will be the same at every combination because the other parts shall be attached to this device.

The head and contact units can be selected by the user. The contact units can simply be clipped-on to the base. The head units can be attached to the base with bayonet lock.

The combinations can be installed into  $\varnothing 22$  mm boreholes; fixation can be made with the fixing screws on the base unit.

## Head units

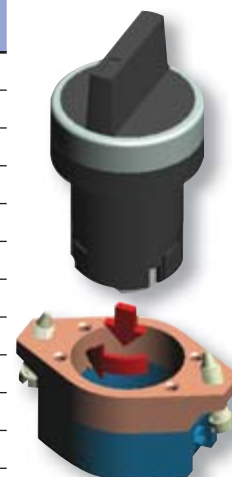

TRACON	Description	a (mm)	b (mm)
■ NYG2-F1	Pushbutton head, red	14	30
■ NYG2-F2	Pushbutton head, green	14	30
■ NYG2-F3	Pushbutton head, yellow	14	30
■ NYG2-F4	Selector switch, with 2-position switch arm (0-1)	28	30
■ NYG2-F5	Selector switch, with 3-position switch arm (1-0-1)	28	30
■ NYG2-F6	Double pushbutton head (ON-OFF) with yellow lamp	18	55
■ NYG2-F7	Mushroom button head, red with STOP sign	22	40
■ NYG2-F8	Mushroom button head, green	22	40
■ NYG2-F9	Mushroom emergency button head, with turn release, 40 mm	28	40
■ NYG2-F10	Mushroom emergency button head, with turn release, 60 mm	30	60
■ NYG2-F11	Mushroom emergency button head, with key release, 40 mm	28	40
■ NYG2-F12	Mushroom button head, transparent orange, 40 mm	26	40



Users can choose from 12 different heads, such as buttons, switches or emergency mushrooms. The head units can be attached to the bases with bayonet lock.



## Bases

TRACON	 M	 Nm
NYG2-T	2 x M4	1,2 Nm

The primary unit of pushbuttons is the base; it will be the same at every combination because the other parts can be attached to this device. The combinations can be installed into  $\varnothing$  22 mm boreholes; fixing can be made with the fixing screws on the basis element.

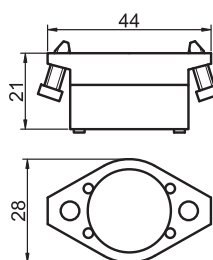

Enclosures

TRACON		W (mm)	H (mm)	x (mm)		IP..
TK/T1+F2/		68	64	44	2 x MG-20	IP 44
TK/T2+F2/		68	80	44	2 x MG-20	IP 44
TK/T1+F2S/		68	64	44	2 x MG-20	IP 44
TK/T2+F2S/		68	80	44	2 x MG-20	IP 44



Light (LED) units



TRACON		Um
NYG2-L1		AC12V
NYG2-L2		AC24V
NYG2-L3		AC230V
NYG2-L4		AC12V
NYG2-L5		AC24V
NYG2-L6		AC230V
NYG2-L7		AC12V
NYG2-L8		AC24V
NYG2-L9		AC230V
NYG2-L10		DC12V
NYG2-L11		DC24V
NYG2-L12		DC12V
NYG2-L13		DC24V
NYG2-L14		DC12V
NYG2-L15		DC24V

Contact units

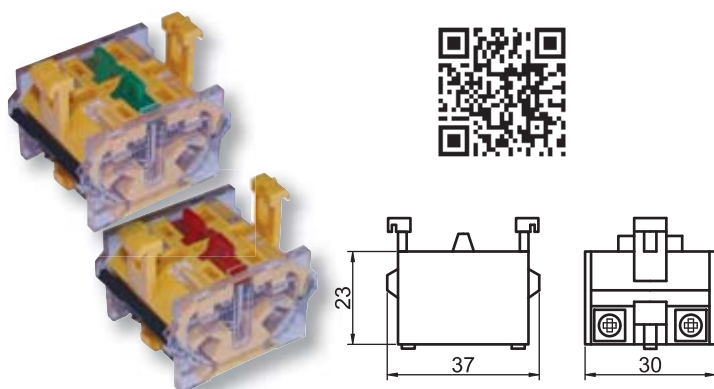

TRACON		NC NO
NYG2-E20		NO+NO
NYG2-E11		NO+NC
NYG2-E02		NC+NC

Every unit contains 2 pcs double contacts, this way 3 different combinations can be chosen. In order to ensure reliable contacts, we advise the grouping of contact units up to 2 levels. The contact units can be simply clipped-on to the bases.



### Possible combinations with LED units

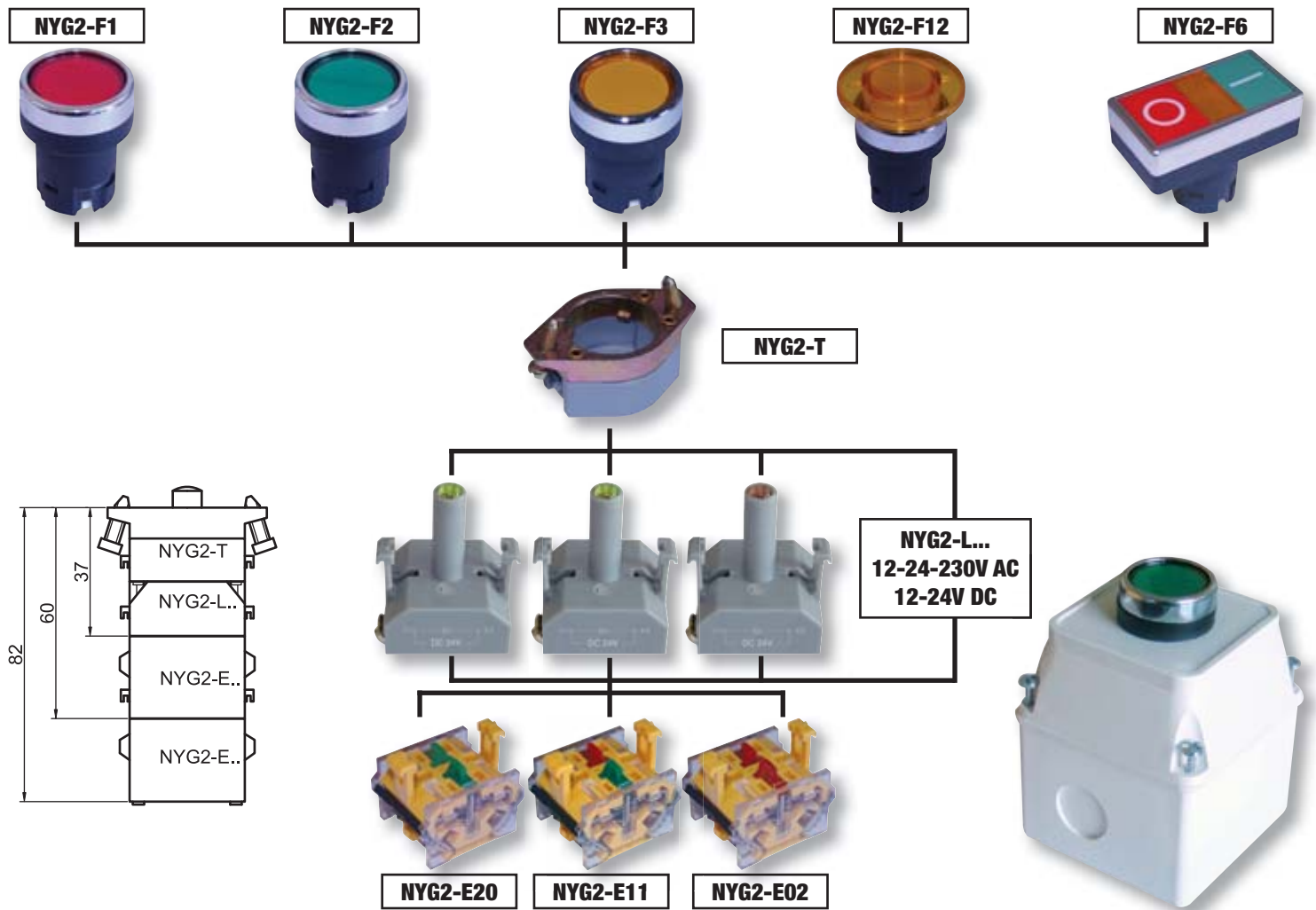

### Possible combinations without LED units





LJL type LED signal lamps

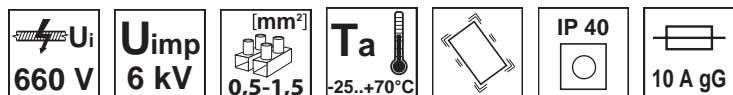

∅ 16 mm versions

TRACON		Um
LJL16-RA		12V AC/DC
LJL16-RC		24 V AC/DC
LJL16-RD		48 V AC/DC
LJL16-RE		230 V AC
LJL16-RF		400 V AC
LJL16-GA		12 V AC/DC
LJL16-GC		24 V AC/DC
LJL16-GD		48 V AC/DC
LJL16-GE		230 V AC
LJL16-GF		400 V AC
LJL16-YA		12 V AC/DC
LJL16-YC		24 V AC/DC
LJL16-YD		48 V AC/DC
LJL16-YE		230 V AC
LJL16-YF		400 V AC
LJL16-WA		12 V AC/DC
LJL16-WC		24 V AC/DC
LJL16-WD		48 V AC/DC
LJL16-WE		230 V AC
LJL16-WF		400 V AC
LJL16-BA		12 V AC/DC
LJL16-BC		24 V AC/DC
LJL16-BD		48 V AC/DC
LJL16-BE		230 V AC
LJL16-BF		400 V AC

∅ 22 mm versions

TRACON			Um	
IP 40				
LJL22-RA	LJL22-RAT		12 V AC/DC	
LJL22-RC	LJL22-RCT		24 V AC/DC	
LJL22-RD	LJL22-RDT		48 V AC/DC	
LJL22-RE	LJL22-RET		230 V AC	
LJL22-RF	LJL22-RFT		400 V AC	
LJL22-GA	LJL22-GAT		12 V AC/DC	
LJL22-GC	LJL22-GCT		24 V AC/DC	
LJL22-GD	LJL22-GDT		48 V AC/DC	
LJL22-GE	LJL22-GET		230 V AC	
LJL22-GF	LJL22-GFT		400 V AC	
LJL22-YA	LJL22-YAT		12 V AC/DC	
LJL22-YC	LJL22-YCT		24 V AC/DC	
LJL22-YD	LJL22-YDT		48 V AC/DC	TK/T1+F2/
LJL22-YE	LJL22-YET		230 V AC	
LJL22-YF	LJL22-YFT		400 V AC	
LJL22-WA	LJL22-WAT		12 V AC/DC	
LJL22-WC	LJL22-WCT		24 V AC/DC	
LJL22-WD	LJL22-WDT		48 V AC/DC	
LJL22-WE	LJL22-WET		230 V AC	
LJL22-WF	LJL22-WFT		400 V AC	
LJL22-BA	LJL22-BAT		12 V AC/DC	
LJL22-BC	LJL22-BCT		24 V AC/DC	
LJL22-BD	LJL22-BDT		48 V AC/DC	
LJL22-BE	LJL22-BET		230 V AC	
LJL22-BF	LJL22-BFT		400 V AC	

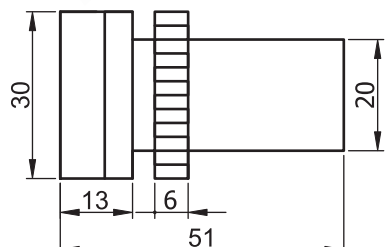
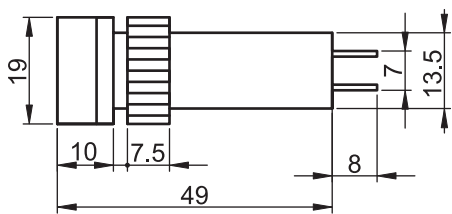

### LJL type LED signal lamps

$U_i$ 660 V	$U_{imp}$ 6 kV	$[mm^2]$ 0,5-1,5	$T_a$ -25..+70°C		10 A gG
----------------	-------------------	---------------------	---------------------	--	---------

Ø 16 mm versions

TRACON		$U_m$
LJL16-AC230B		230 V AC
LJL16-DC230B		230 V DC
LJL16-AC230R		230 V AC
LJL16-DC230R		230 V DC
LJL16-AC230Y		230 V AC
LJL16-DC230Y		230 V DC
LJL16-AC230G		230 V AC
LJL16-DC230G		230 V DC

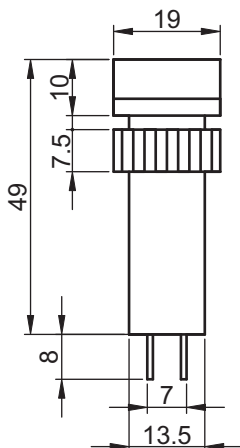

Ø 22 mm versions

TRACON			$U_m$
IP 40			
LJL22-ACDC24W	LJL22-ACDC24WT		24 V AC/DC
LJL22-AC230W	LJL22-AC230WT		230 V AC
LJL22-DC230W	LJL22-DC230WT		230 V DC
LJL22-ACDC24B	LJL22-ACDC24BT		24 V AC/DC
LJL22-AC230B	LJL22-AC230BT		230 V AC
LJL22-DC230B	LJL22-DC230BT		230 V DC
LJL22-ACDC24R	LJL22-ACDC24RT		24 V AC/DC
LJL22-AC230R	LJL22-AC230RT		230 V AC
LJL22-DC230R	LJL22-DC230RT		230 V DC
LJL22-ACDC24Y	LJL22-ACDC24YT		24 V AC/DC
LJL22-AC230Y	LJL22-AC230YT		230 V AC
LJL22-DC230Y	LJL22-DC230YT		230 V DC
LJL22-ACDC24G	LJL22-ACDC24GT		24 V AC/DC
LJL22-AC230G	LJL22-AC230GT		230 V AC
LJL22-DC230G	LJL22-DC230GT		230 V DC

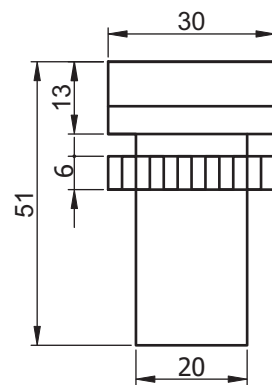

### Enclosures

TRACON		W (mm)	H (mm)	x (mm)		IP..
--------	--	--------	--------	--------	--	------

TK/T1+F2/ 68 64 44 2 x MG-20 IP 44

TÜV MEEI TEST DOCUMENTATION  
**V-15180**

RELEVANT STANDARD  
**EN 60529**

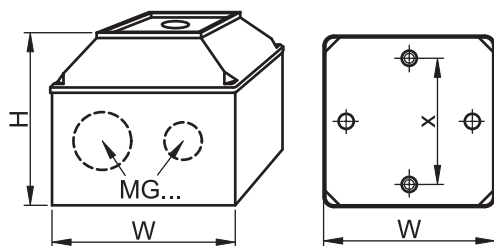



TES device switches

<b>U<sub>m</sub></b> max. 250 V	<b>I<sub>e</sub></b> (AC 1, 230 V) <b>16 A</b>	<b>I<sub>e</sub></b> (AC 15, 230 V) <b>6 A</b>	<b>I<sub>e</sub></b> (DC 13, 250 V) <b>0,27 A</b>	<b>U<sub>i</sub></b> <b>660 V</b>	<b>U<sub>imp</sub></b> <b>6 kV</b>	<b>[mm<sup>2</sup>]</b> <b>0,5-2,5</b>	<b>5x10<sup>4</sup></b>	<b>[h]</b> <b>15.000</b>	<b>% rH</b> <b>max. 95</b>	<b>T<sub>a</sub></b> <b>-20..+55°C</b>	<b>IP 40</b>	<b>10 A gG</b>
------------------------------------	---	---	--	--------------------------------------	---------------------------------------	---	-------------------------	-----------------------------	-------------------------------	---	--------------	----------------

The device switches are suitable to be installed into various control devices, household machines and other electrical equipment. We suggest installing the device switches provided with signal lights in such places where it is important to indicate the ON condition of the equipment. The switch can be easily snapped into the mounting hole and wires equipped with 4,6 × 0,8 and 6,3 × 0,8 flat, slip-on, female clips can be connected onto its standard terminals.

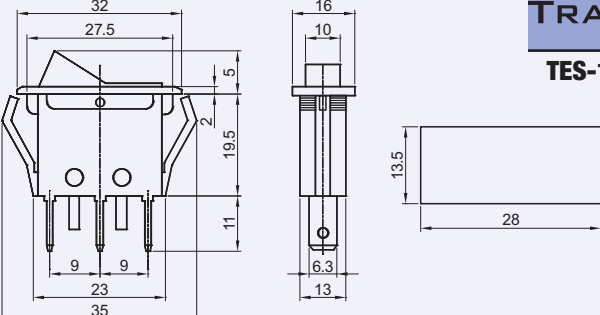
**ON-OFF switch**



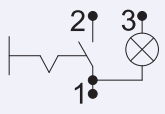

**TRACON** 

**TES-11** 6,3 × 0,8 mm  ✓

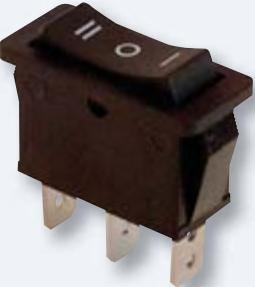
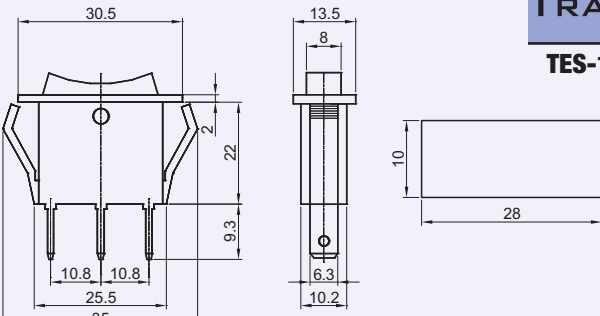

**Middle 0 position switch**



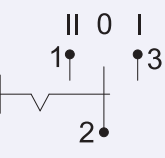

**TRACON** 

**TES-12** 6,3 × 0,8 mm **I-0-II**  -

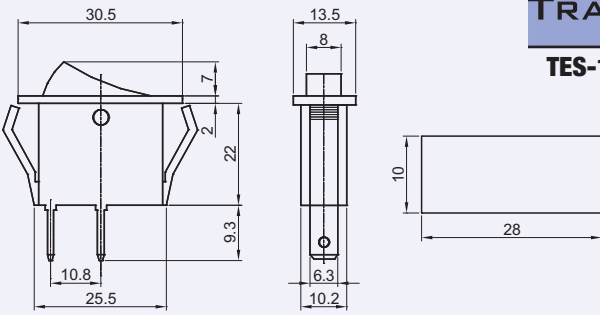

**ON-OFF switch**



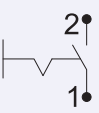

**TRACON** 

**TES-13** 6,3 × 0,8 mm **0-I**  -

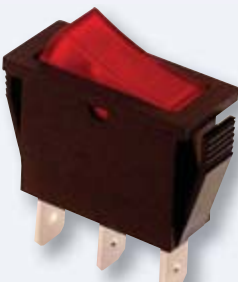
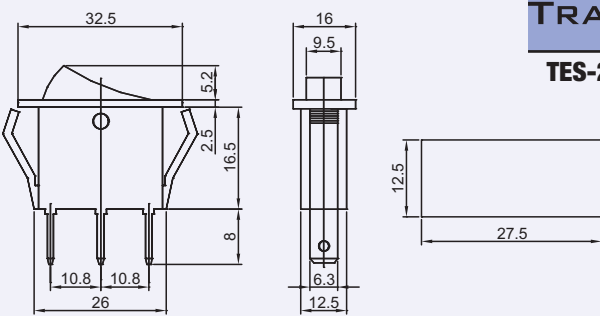

**ON-OFF switch**

**TRACON** 

**TES-21** 6,3 × 0,8 mm  ✓



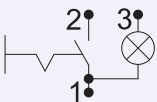

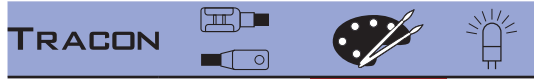
**TES-22** 4,8 × 0,8 mm

**0-1**

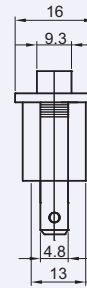
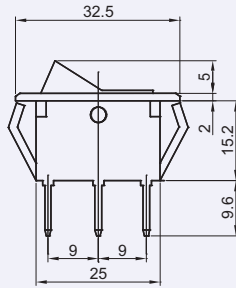
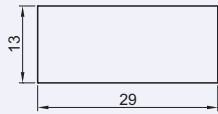
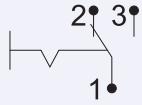

**Alternate switch**

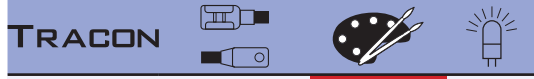

**TES-33** 4,8 × 0,8 mm

**0-1**

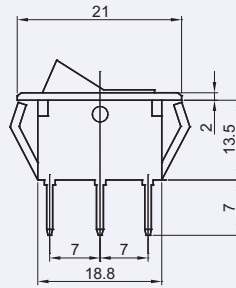
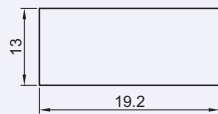
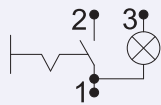

**ON-OFF switch**

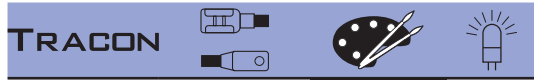

**TES-34** 4,8 × 0,8 mm

**0-1**

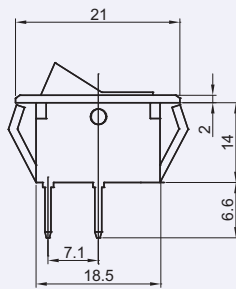
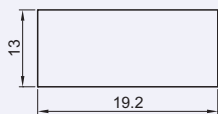
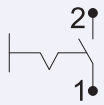

**ON-OFF switch**





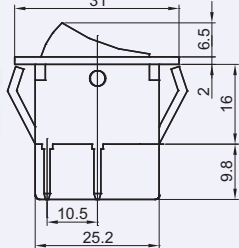
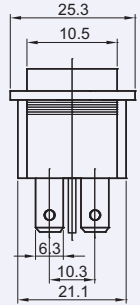
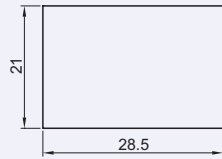
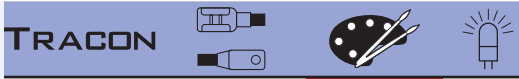

**2 poles switch ON-OFF switch**

**TES-41** 6,3 × 0,8 mm   ✓

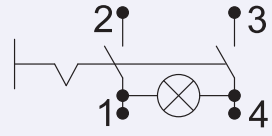

**2 poles switch ON-OFF switch**

**TES-42** 6,3 × 0,8 mm 0-1 ✓

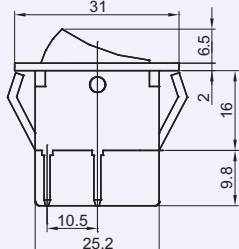
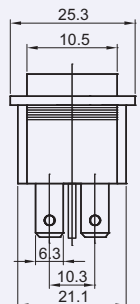
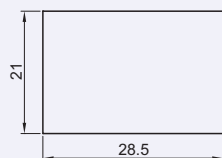
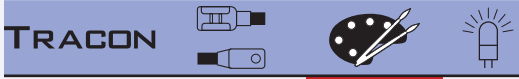

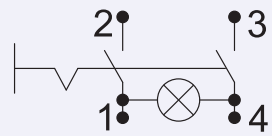
**ON-OFF switch**

**TES-43** 6,3 × 0,8 mm 0-1, 0-1 ✓

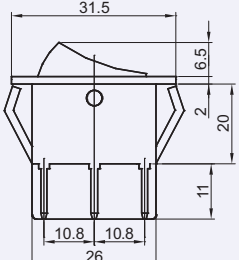
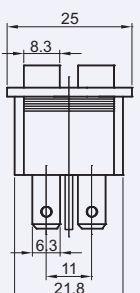
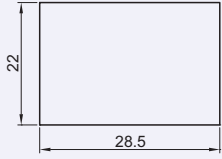
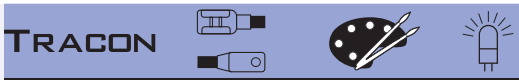

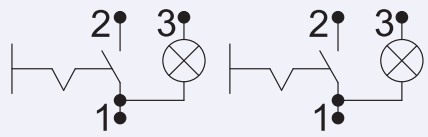
**2 poles switch ON-OFF switch**

**TES-44** 6,3 × 0,8 mm 0-1 ✓

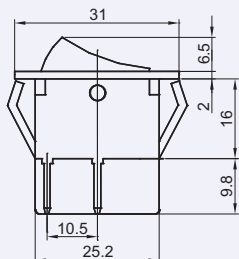
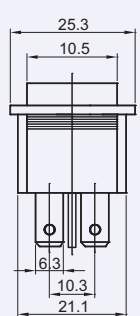
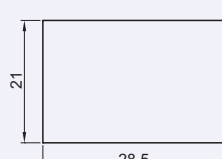
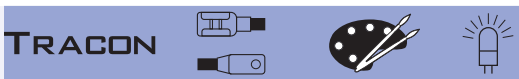

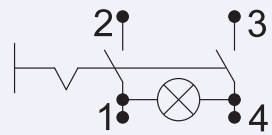
**2 poles switch ON-OFF switch**



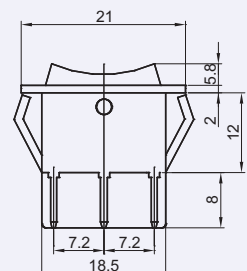
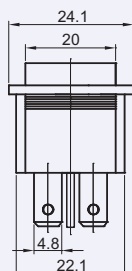
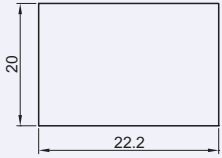
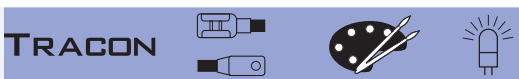

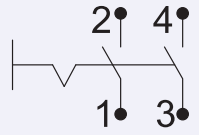

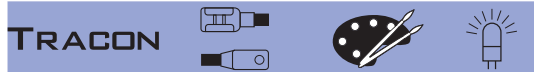
**TES-51** 4,8 × 0,8 mm 0-1 -



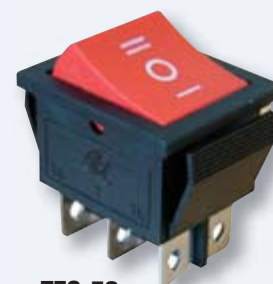
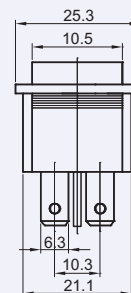
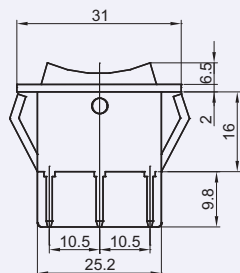
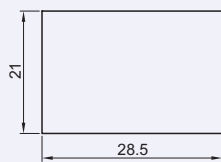
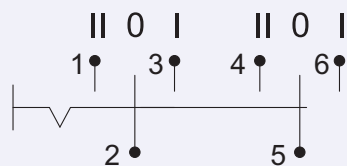

<b>TES-52</b>	6,3 × 0,8 mm	<b>I-0-II</b>	-
<b>TES-52-1</b>	6,3 × 0,8 mm	<b>I-0-II</b>	✓
<b>TES-52-2</b>	6,3 × 0,8 mm	<b>I-0-II</b>	-



TES-52

2 poles switch ON-OFF switch

2 poles switch ON-OFF switch



TES-52-1

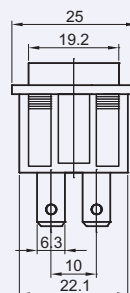
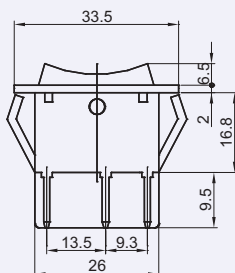
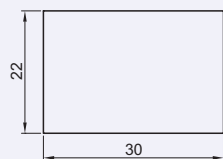

2 poles switch ON-OFF switch (With spring return)



TES-52-2

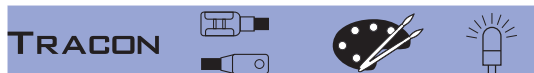

<b>TES-53</b>	6,3 × 0,8 mm	<b>0-1</b>	-
---------------	--------------	------------	---

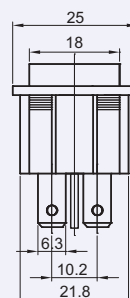
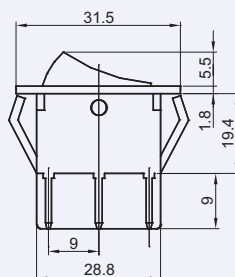
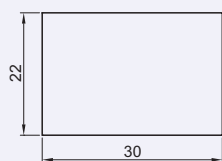
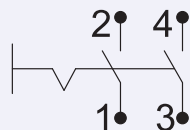

2 poles switch ON-OFF switch

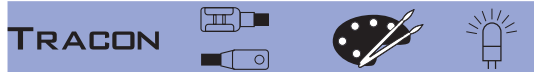

<b>TES-53-1</b>	6,3 × 0,8 mm	<b>0-1</b>	-
-----------------	--------------	------------	---

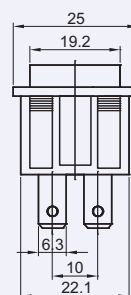
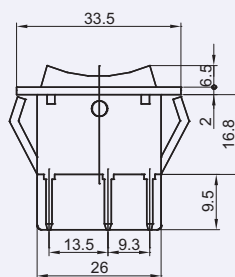
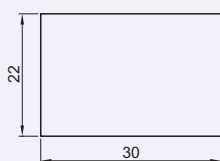
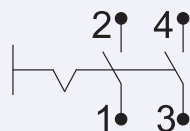

2 poles switch ON-OFF switch (With spring return)



TRACON

**TES-GB** IP 55

Can be fitted to next versions:

- TES-42
- TES-43
- TES-52
- TES-52-1
- TES-52-2
- TES-53

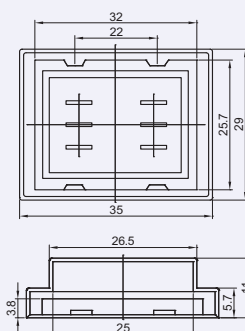

PVC membrane



Small disconnecter transformers TVTR

TRACON	P <sub>n</sub>	U <sub>pr</sub>	U <sub>sec</sub>	P <sub>sec</sub> *	I <sub>sec</sub>
TVTR-50-A	50 VA	230 V	3-6-12-18-24 V	6,25-12,5-25-37,5-50 VA	2,08 A
TVTR-50-B		230 V	6-12-18-24 V	12,5-25-37,5-50 VA	2,08 A
TVTR-50-C		230 V	12-24-42 V	14,2-28,5-50 VA	1,19 A
TVTR-50-D		230 V	24-42-110 V	10-19-50 VA	0,45 A
TVTR-50-F		230 V	24-230 V	5,2-50 VA	0,21 A
TVTR-100-A		100 VA	230 V	3-6-12-18-24 V	12,5-25-50-75-100 VA
TVTR-100-B	230 V		6-12-18-24 V	25-50-75-100 VA	4,16 A
TVTR-100-C	230 V		12-24-42 V	28,5-57,1-100 VA	2,38 A
TVTR-100-D	230 V		24-42-110 V	21,8-38,1-100 VA	0,90 A
TVTR-100-F	230 V		24-230 V	10,4-100 VA	0,43 A
TVTR-150-B	150 VA		230 V	6-12-18-24 V	37,5-75-112,5-150 VA
TVTR-150-C		230 V	12-24-42 V	42,8-85,7-150 VA	3,57 A
TVTR-150-D		230 V	24-42-110 V	32,7-57,2-150 VA	1,36 A
TVTR-150-E		230 V	42-110-230 V	27,3-71,7-150 VA	0,65 A
TVTR-150-F		230 V	24-230 V	15,6-150 VA	0,65 A
TVTR-200-B		200 VA	230 V	6-12-18-24 V	50-100-150-200 VA
TVTR-200-C	230 V		12-24-42 V	57,1-114,2-200 VA	4,76 A
TVTR-200-D	230 V		24-42-110 V	43,6-76,3-200 VA	1,81 A
TVTR-200-E	230 V		42-110-230 V	36,5-95,6-200 VA	0,86 A
TVTR-200-F	230 V		24-230 V	20,8-200 VA	0,86 A

\* depending on the secondary voltage at the tapping exit;



In these devices the primary coil is separated from the secondary coil by a basic insulator. They can be used for power transmission, control, signalling actuating or other low voltage electric circuits, e.g. to generate **functional low voltage (FELV)** according to the standard **HD 60364-4-41** or to perform electrical protection to a secondary consumer with simple insulation.

The transformers deliver one-phase power with eight different secondary voltage values (U<sub>sec</sub>=3-6-12-18-24-42-110-230 V).

The transformers are built in conformity to the requirements within **EN 60742** and **EN 61558**. Their degree of protection is IP00, i. e. they are meant to be built in as parts into another equipment. Connections are ensured by screwed connectors with IP 20 degree of protection. Rated powers range between 50 – 630 VA, depending on construction. The secondary coil has more wiretapping exits. The rated power refers to the highest secondary voltage value. At the other wire-tapping exits the transformer delivers proportionally lower power values (see table).

RELEVANT STANDARD  
**EN 61558-1**

RELEVANT STANDARD  
**EN 61558-2-1**



**SCAN THE QR CODE!**

- Check our new products
- Be updated

**Our assortment is expanding quickly and continuously! Our catalogue shows the assortment of January 2017. Be up to date by our web page!**

TRACON	$P_n$	$U_{pr}$	$U_{sec}$	$P_{sec}$ *	$I_{sec}$
TVTR-250-B	250 VA	230 V	6-12-18-24 V	62,5-125-187,5-250 VA	10,41 A
TVTR-250-C		230 V	12-24-42 V	71,4-142,8-250 VA	5,95 A
TVTR-250-D		230 V	24-42-110 V	54,5-95,4-250 VA	2,27 A
TVTR-250-E		230 V	42-110-230 V	45,6-119,5-250 VA	1,08 A
TVTR-250-F		230 V	24-230 V	26-250 VA	1,08 A
TVTR-300-B		300 VA	230 V	6-12-18-24 V	75-150-225-300 VA
TVTR-300-C	230 V		12-24-42 V	85,7-171,4-300 VA	7,14 A
TVTR-300-D	230 V		24-42-110 V	65,4-114,5-300 VA	2,72 A
TVTR-300-E	230 V		42-110-230 V	54,7-143,4-300 VA	1,30 A
TVTR-300-F	230 V		24-230 V	31,3-300 VA	1,30 A
TVTR-400-B	400 VA		230 V	6-12-18-24 V	100-200-300-400 VA
TVTR-400-C		230 V	12-24-42 V	114,2-228,5-400 VA	9,52 A
TVTR-400-D		230 V	24-42-110 V	87,2-152,7-400 VA	3,63 A
TVTR-400-E		230 V	42-110-230 V	73-191,3-400 VA	1,73 A
TVTR-400-F		230 V	24-230 V	41,7-400 VA	1,73 A
TVTR-500-C		500 VA	230 V	12-24-42 V	142,8-285,7-500 VA
TVTR-500-D	230 V		24-42-110 V	109-190,9-500 VA	4,54 A
TVTR-500-E	230 V		42-110-230 V	91,3-239,1-500 VA	2,17 A
TVTR-500-F	230 V		24-230 V	52,1-500 VA	2,17 A
TVTR-630-C	630 VA	230 V	12-24-42 V	180-360-630 VA	15 A
TVTR-630-D		230 V	24-42-110 V	137,4-240,5-630 VA	5,72 A
TVTR-630-E		230 V	42-110-230 V	115-301,3-630 VA	5,73 A
TVTR-630-F		230 V	24-230 V	65,7-630 VA	2,73 A

\* depending on the secondary voltage at the tapping exit;

TRACON	A (mm)	B (mm)	C (mm)	D (mm)	E (mm)	F (mm)	G (mm)	H (mm)	I (mm)	
TVTR-50	75	80	77	50	56	10	5,5	28	4	1,2 kg
TVTR-100	85	90	85	59	64	10	5,5	40	5	1,9 kg
TVTR-150	98	90	95	65	84	12	6	40	5	2,6 kg
TVTR-200	98	100	95	74	84	12	6	40	5	3,1 kg
TVTR-250	98	110	95	84	84	12	6	40	5	3,6 kg
TVTR-300	110	110	103	82	90	12	6	-	-	4,6 kg
TVTR-400	123	112	110	84	90	14	7	50	5	5,3 kg
TVTR-500	122	120	107	98	90	14	7	50	5	6,3 kg
TVTR-630	154	115	135	87	122	22	8	50	5	7,2 kg

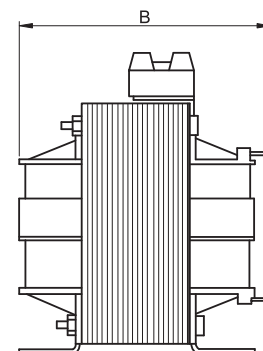
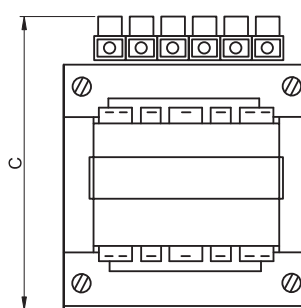
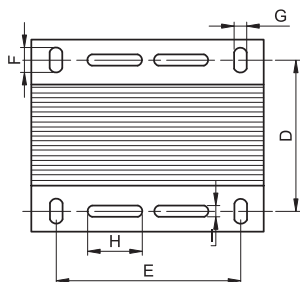
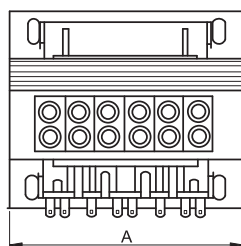

**SCAN THE QR CODE!**

- Check our new products
- Be updated

**Our assortment is expanding quickly and continuously! Our catalogue shows the assortment of January 2017. Be up to date by our web page!**



# One-phase insulating transformers TVTRB

TRACON	P <sub>n</sub>	U <sub>pr</sub>	U <sub>sec</sub>	P <sub>sec</sub> *	I <sub>sec</sub>
TVTRB-60-A	60 VA	230-400 V	6-12-24 V	15-30-60 VA	2,5 A
TVTRB-60-F		230-400 V	24-230 V	6,2-60 VA	0,26 A
TVTRB-60-M		230 V	12 V	60 VA	5 A
TVTRB-60-O		230 V	42 V	60 VA	1,43 A
TVTRB-100-A	100 VA	230-400 V	6-12-24 V	25-50-100 VA	4,17 A
TVTRB-100-D		230-400 V	24-42 V	57,1-100 VA	2,38 A
TVTRB-100-F		230-400 V	24-230 V	10,4-100 VA	0,43 A
TVTRB-100-M		230 V	12 V	100 VA	8,33 A
TVTRB-100-O		230 V	42 V	100 VA	2,38 A

\* depending on the secondary voltage at the tapping exit;

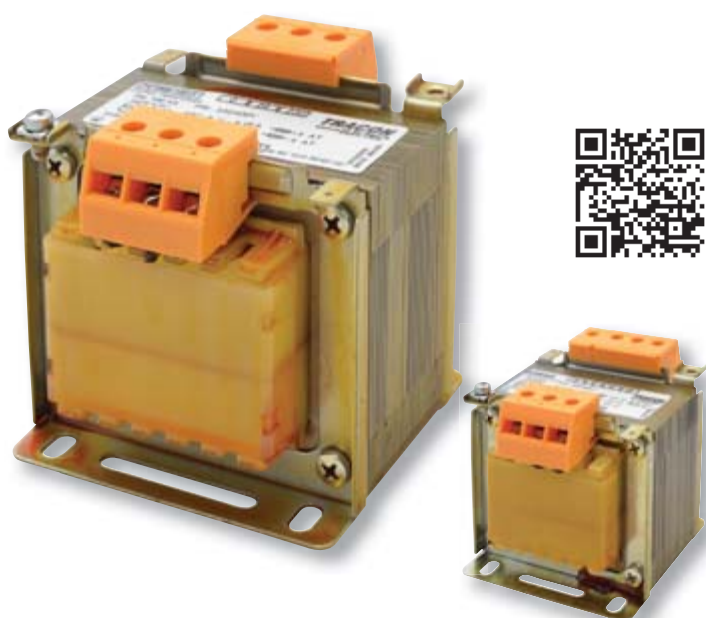

These products are meant for insulating separation in low-voltage power transmission, actuating, signalling, control and other circuits, to generate **shock-proof low voltage (SELV)** according to the standard **MSZ HD 60364-4-41**. A protective separation is built in between the primary and secondary coil.

The safety insulating transformers deliver at the secondary side so-called safety low voltage below 50 V. The insulating transformers deliver at the secondary side low voltage above 50 V.

All our transformers satisfy the requirements set within **EN 60742** and **EN 61558**. Their degree of protection is IP00, i. e. they are meant to be built in as parts into another equipment. Connections are ensured by screwed connectors with IP 20 degree of protection.

Rated powers range between 60 – 600 VA, depending on construction. The secondary coil has more wire-tapping exits.

The rated power refers to the highest secondary voltage value. At the other wire-tapping exits the transformer delivers proportionally lower power values (see table).

RELEVANT STANDARD  
**EN 61558-1**

RELEVANT STANDARD  
**EN 61558-2-1**



**Key to electricity**

TRACON ELECTRIC®

Tracon Key to electricity

TRACON	$P_n$	$U_{pr}$	$U_{sec}$	$P_{sec}$ *	$I_{sec}$
TVTRB-160-B	160 VA	230-400 V	12-24 V	80-160 VA	6,67 A
TVTRB-160-F		230-400 V	24-230 V	16,7-160 VA	0,70 A
TVTRB-160-M		230 V	12 V	160 VA	13,34 A
TVTRB-160-O		230 V	42 V	160 VA	3,81 A
TVTRB-250-B	250 VA	230-400 V	12-24 V	125-250 VA	10,42 A
TVTRB-250-D		230-400 V	24-42 V	142,9-250 VA	5,95 A
TVTRB-250-F		230-400 V	24-230 V	26-250 VA	1,09 A
TVTRB-250-O		230 V	42 V	250 VA	5,95 A
TVTRB-400-B	400 VA	230-400 V	12-24 V	200-400 VA	16,67 A
TVTRB-400-D		230-400 V	24-42 V	228,6-400 VA	9,52 A
TVTRB-400-F		230-400 V	24-230 V	41,74-400 VA	1,74 A
TVTRB-400-O		230 V	42 V	400 VA	9,52 A
TVTRB-400-R		400 V	24 V	400 VA	16,67 A
TVTRB-600-B	600 VA	230-400 V	12-24 V	300-600 VA	25 A
TVTRB-600-D		230-400 V	24-42 V	342,9-600 VA	14,29 A
TVTRB-600-F		230-400 V	24-230 V	62,6-600 VA	2,61 A
TVTRB-600-O		230 V	42 V	600 VA	14,29 A
TVTRB-600-R		400 V	24 V	600 VA	25 A

\* depending on the secondary voltage at the tapping exit;

TRACON	A (mm)	B (mm)	C (mm)	D (mm)	E (mm)	F (mm)	G (mm)	H (mm)	I (mm)	
TVTRB-60	75	90	76	60	56	10	5	28	4	1,5 kg
TVTRB-100	84	89	84	54	64	10	5,5	40	5	2,0 kg
TVTRB-160	96	80	108	70	84	11	5,8	35	3,6	2,4 kg
TVTRB-250	98	98	95	65	84	12	6	40	5	2,7 kg
TVTRB-400	123	115	110	84	90	14	7	50	5	5,3 kg
TVTRB-600	155	135	135	98	122	22	8	50	5	7,7 kg

RELEVANT STANDARD  
EN 61558-1

RELEVANT STANDARD  
EN 61558-2-1

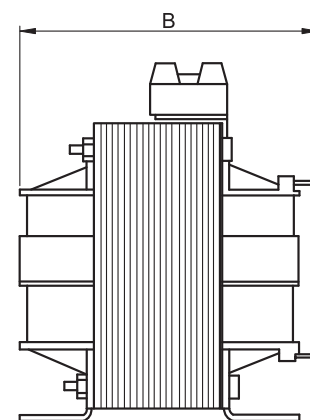
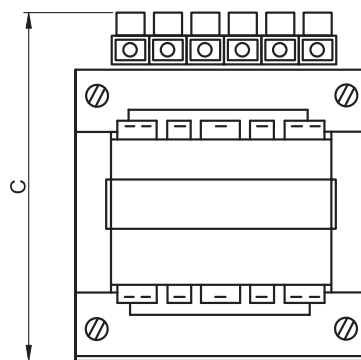
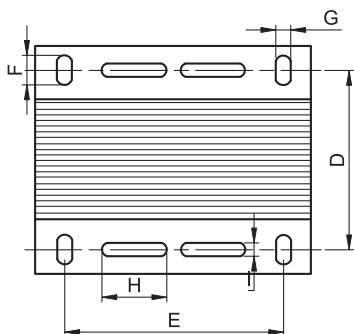
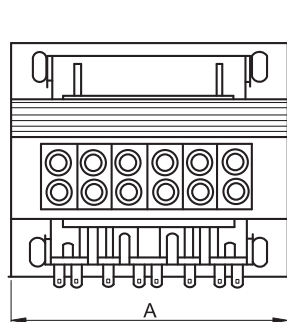

SCAN THE QR CODE!

- Check our new products
- Be updated

Our assortment is expanding quickly and continuously! Our catalogue shows the assortment of January 2017. Be up to date by our web page!