



Terminal blocks



Main line branching terminal strip

These distribution blocks enable multiple branching from a main line. They are primarily meant for use in distribution cabinets and boxes. The terminals accept round copper wires, solid or twisted. The plastic body is made of heat-resistant, self-extinguishing (UL94-V0) polyamide of high mechanical strength.

The terminal strips can be fastened to rails meeting the requirements of EN 50022.

Technical data

Nominal voltage:	400 V AC	Fastening:	to be clapped on rail 35 × 7.5 mm
Nominal frequency:	50/60 Hz	Fastening torque:	see Appendix
Nominal insulation voltage:	500 V	Degree of protection:	IP 20
Clamp material:	brass	Ambient temperature:	-10°C – +55 °C

Tracon code	Accepted wire section (mm ²)				Rated current (A)	Colour	Screw size	
	supply side (mm ²)		branch-off side (mm ²)				supply side	branchoff side
	solid	flexible	solid	flexible				
FLS35/4X9	1×35	1×25	9×4	9×2.5	125	grey	1 pc M8	9 pcs M4
FLS35/4X9-B	1×35	1×25	9×4	9×2.5		blue	1 pc M8	9 pcs M4
FLS35/4X9-ZS	1×35	1×25	9×4	9×2.5		green - yellow	1 pc M8	9 pcs M4
FLS35/10X4	1×35	1×25	4×10	4×6	125	grey	1 pc M8	4 pcs M5
FLS35/10X4-B	1×35	1×25	4×10	4×6		blue	1 pc M8	4 pcs M5
FLS35/10X4-ZS	1×35	1×25	4×10	4×6		green - yellow	1 pc M8	4 pcs M5
FLS50/16X4	1×50	1×35	4×16	4×10	150	grey	1 pc M8	4 pcs M6
FLS50/16X4-B	1×50	1×35	4×16	4×10		blue	1 pc M8	4 pcs M6
FLS50/16X4-ZS	1×50	1×35	4×16	4×10		green - yellow	1 pc M8	4 pcs M6
FLS70/10X8	1×70	1×50	8×10	8×6	192	grey	1 pc M10	8 pcs M6
FLS70/10X8-B	1×70	1×50	8×10	8×6		blue	1 pc M10	8 pcs M6
FLS70/10X8-ZS	1×70	1×50	8×10	8×6		green - yellow	1 pc M10	8 pcs M6

RELEVANT STANDARD
EN 60998-1

RELEVANT STANDARD
EN 60998-2-1

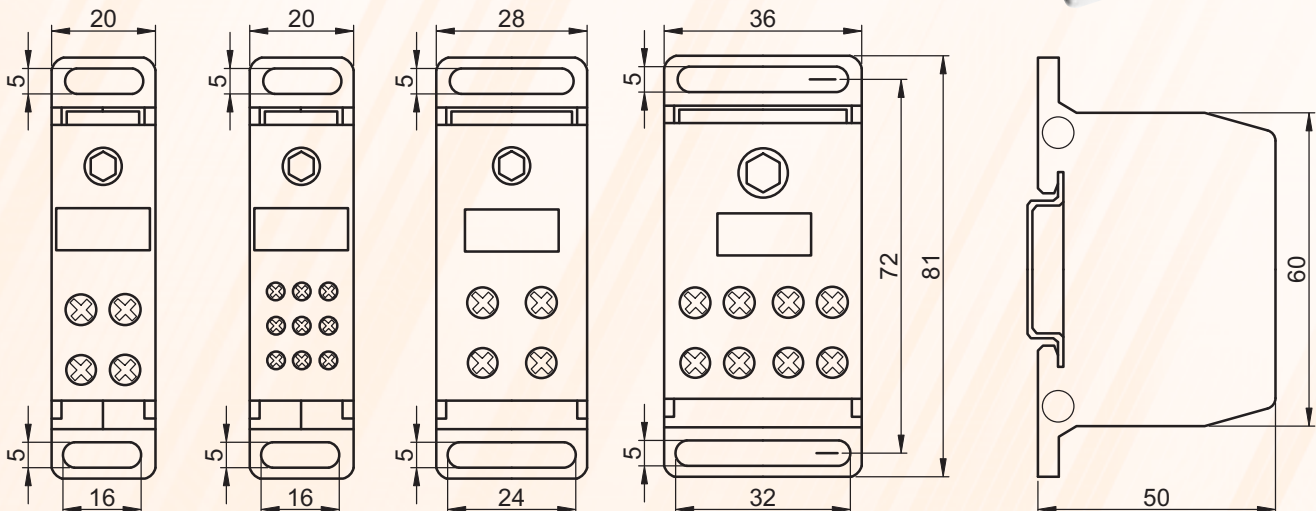

Terminal blocks

Flexible and bakelite terminal strips

These terminals enable fast and reliable connection of low voltage consumers to the supply network. The standard 12-connector strips can be divided (cut) into smaller units, as necessary. The version provided with pressing plate divides the pressing force of the fixing screw on the entire surface of the connected wire, thus further enhancing the mechanical and electrical protection of the connection. The ST type version enables fixation of large cross-section wires in the bakelite case with two fixing screws each.

H-profile flexible terminal strips

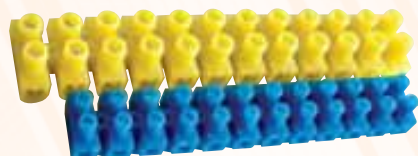

Traditional version

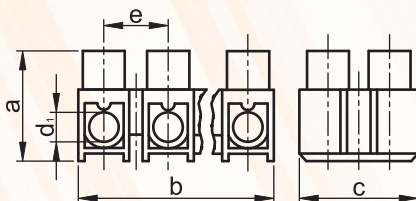

Pressing plate equipped version

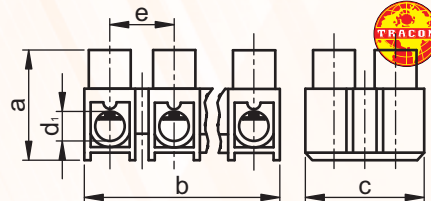

Technical data

Nominal insulation voltage: 450 V
 Suggested fastening torque: 0.4-0.8 Nm
 Insulator material: Polyamide 6.6
 Ambient temperature: -20 °C ÷ +75 °C

FIMKO IECEE-CB CERTIFICATE NO.

FI748, FI876, FI952

RELEVANT STANDARD

**EN 60998-1
 EN 60998-2-1**

Traditional version

Profile	Tracon code	Colour	Wire (mm ²)	Contacts	Rated current (A)	Diameter of copper wire (mm)			d ₁ (mm)	a (mm)	b (mm)	c (mm)	e (mm)
						solid	wisted	flexible					
„H”	S3A-H	clear	2,5	12 pcs	16	1.9	2.2	2.3	3	11	93.2	11	7.5
	SF3A-H	black		12 pcs									
	S5A-H	clear	4	12 pcs	25	2.4	2.7	2.9	3.2	13	114.8	13	9.7
	SF5A-H	black		12 pcs									
	S10A-H	clear	6	12 pcs	40	2.9	3.3	2.9	4.2	15.3	131.5	15.3	11.1
	SF10A-H	black		12 pcs									
	S15A-H	clear	10	12 pcs	50	2.9	3.3	2.9	4.5	16.6	137.3	22.5	11.5
	SF15A-H	black		12 pcs									
	S30A-H	clear	16	12 pcs	63	3.7	4.2	3.9	5.5	19.2	169	19.2	14.5
	SF30A-H	black		12 pcs									
	S60A-H	clear	25	12 pcs	80	-	6.6	6.3	6.6	24.4	191	24.4	16
	SF60A-H	black		12 pcs									

Pressing plate version

Profile	Tracon code	Colour	Wire (mm ²)	Contacts	Rated current (A)	Diameter of copper wire (mm)			d ₁ (mm)	a (mm)	b (mm)	c (mm)	e (mm)
						solid	wisted	flexible					
„H”	S3A-H-L	clear	2,5	12 pcs	16	1.9	2.2	2.3	3	11	93.2	11	7.5
	SF3A-H-L	black		12 pcs									
	S5A-H-L	clear	4	12 pcs	25	2.4	2.7	2.9	3.2	13	114.8	13	9.7
	SF5A-H-L	black		12 pcs									
	S10A-H-L	clear	6	12 pcs	40	2.9	3.3	2.9	4.2	15.3	131.5	15.3	11.1
	SF10A-H-L	black		12 pcs									
	S30A-H-L	clear	16	12 pcs	63	3.7	4.2	3.9	5.5	19.2	169	19.2	14.5
	SF30A-H-L	black		12 pcs									
	S60A-H-L	clear	25	12 pcs	80	-	6.6	6.3	6.6	24.4	191	24.4	16
	SF60A-H-L	black		12 pcs									



Terminal blocks

U-profile flexible terminal strips

Technical data

Suggested fastening torque: 0.4-0.8 Nm
 Insulation material: Polyamide 6.6
 Ambient temperature: -20 °C ÷ +75 °C

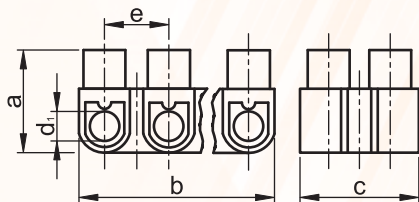

RELEVANT STANDARD

EN 60998-1
EN 60998-2-1

FIMKO IECEE-CB CERTIFICATE NO.

FI748, FI876, FI952

Profile	Tracon code	Colour	Wire (mm ²)	Contacts	Rated current (A)	Diameter of copper wire (mm)			d ₁ (mm)	a (mm)	b (mm)	c (mm)	e (mm)
						solid	wisted	flexible					
„U”	S3A-U	clear	12 pcs	2,5	16	1.9	2.2	2.3	3	10.8	91.4	15.6	7.6
	S5A-U	clear	12 pcs	4	25	2.4	2.7	2.9	3.3	12.8	112.5	15.5	9.5
	S10A-U	clear	12 pcs	6	40	2.9	3.3	2.9	4.2	15	128	20.6	10.8
	SF10A-U	black	12 pcs			2.9	3.3	2.9	4.2	15	128	20.6	10.8
	SK10A-U	blue	12 pcs			2.9	3.3	2.9	4.2	15	128	20.6	10.8
	SP10A-U	red	12 pcs			2.9	3.3	2.9	4.2	15	128	20.6	10.8
	SS10A-U	yellow	12 pcs			2.9	3.3	2.9	4.2	15	128	20.6	10.8
	SZ10A-U	green	12 pcs			2.9	3.3	2.9	4.2	15	128	20.6	10.8
	S15A-U	clear	12 pcs	10	50	2.9	2.9	3.3	4.5	16.6	137.3	22.5	12
	SF15A-U	black	12 pcs			2.9	2.9	3.3	4.5	16.6	137.3	22.5	12
	SK15A-U	blue	12 pcs			2.9	2.9	3.3	4.5	16.6	137.3	22.5	12
	SP15A-U	red	12 pcs			2.9	2.9	3.3	4.5	16.6	137.3	22.5	12
	SS15A-U	yellow	12 pcs			2.9	2.9	3.3	4.5	16.6	137.3	22.5	12
	SZ15A-U	green	12 pcs			2.9	2.9	3.3	4.5	16.6	137.3	22.5	12
	S30A-U	clear	12 pcs	16	63	3.7	4.2	3.9	5.6	19	164.5	25.3	19
	SF30A-U	black	12 pcs			3.7	4.2	3.9	5.6	19	164.5	25.3	19
	SK30A-U	blue	12 pcs			3.7	4.2	3.9	5.6	19	164.5	25.3	19
	S60A-U	clear	12 pcs	25	80	-	6.6	6.3	6.6	24	185.5	29.2	15.8
	SF60A-U	black	12 pcs			-	6.6	6.3	6.6	24	185.5	29.2	15.8
	SK60A-U	blue	12 pcs			-	6.6	6.3	6.6	24	185.5	29.2	15.8

Bakelite terminal strips

Technical data

Nominal insulation voltage: 450 V
 Suggested fastening torque: 0.4-0.8 Nm
 Insulation material: bakelite (thermally hardening plastic)
 Ambient temperature: -20 °C – +75 °C



BSK

ST

FIMKO IECEE-CB CERTIFICATE NO.

FI748, FI876, FI952

FIMKO IECEE-CB CERTIFICATE NO.

FI748, FI876, FI952

RELEVANT STANDARD

EN 60998-1

RELEVANT STANDARD

EN 60998-2-1

Tracon code	Colour	Ccontacts	Wire (mm ²)	Rated current (A)	Diameter of copper wire (mm)			Height (mm)	Width (mm)	Length (mm)	Screw size
					solid	twisted	flexible				
BSK-6A	black	12 pcs	2,5	10	1.9	2.2	2.3	14.7	20	117.3	M3
BSK-15A	black	12 pcs	4	16	2.4	2.7	2.9	16.5	24.4	136.5	M3
BSK-30A	black	12 pcs	6	25	2.9	3.3	2.9	22.5	29.3	178.5	M3.5
BSK-40A	black	12 pcs	10	40	2.9	2.9	3.3	24	30	190	M3.5
ST63	black	1 pc	10-25	63	1.9-3.7	2.2-6.6	2.3-6.3	40	17	65	M8
ST100	black	1 pc	16-50	100	-	-	-	43	22	65	M10
ST160	black	1 pc	25-70	160	-	-	-	45	15	65	M10



Terminal blocks

A

TSKA industrial terminal blocks family

The TSKA industrial terminal blocks family has several connection joints, insulated from each other. They are mainly used in industry and in measuring circuits, in control and energy distribution boxes. The terminal blocks can be used for jointing of circle section copper wires. The highly heat resistant, strong, self-extinguishing (according to UL94-V0) polyamide plastic house with good electrical parameters – witch contains the electrical elements - , is shaped in a way to permit the terminal block to be fixed onto mounting rails according standard EN 50022 („hat” or „C” rail).

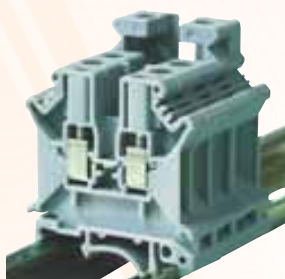

General purpose terminal blocks

In the conventional application these terminal blocks are suited for jointing max. 25 mm² cross-section, phase conductors. One side of the plastic house is opened. At the end of terminal block the connection can be closed with a VL marked end-plate.



Heavy current terminal blocks

These terminal blocks are suited for jointing max. 35-185 mm² cross-sections phase conductors. The female connections are made of pressed metal frame. The plastic house of the terminal blocks is closed from both sides.

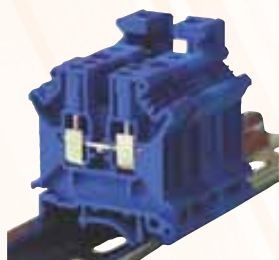

Neutral conductor terminal blocks

They have same construction as the general purpose terminal blocks, however due to its blue color plastic house is suited for jointing the neutral conductor, being visually different from the phase conductor.



Heavy current, neutral conductor terminal blocks

They have same construction as the general purpose, heavy current terminal blocks, however due to its blue color plastic house is suited for jointing the neutral conductor, being visually different from the phase conductor.

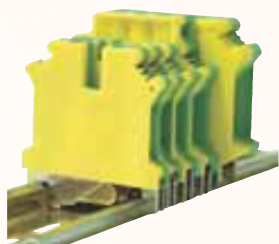

Protective conductor terminal blocks

They are suitable to make electrical and mechanical connection between PE conductors and the grounded mounting rail. The terminal blocks are also suited to joint PEN and PE conductors.

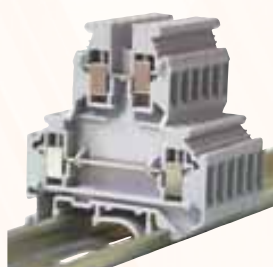

Double-deck terminal blocks

They are suitable for jointing wires of two separated circuits. Due to proper construction of plastic house the two terminal levels can be easy handled by a screwdriver. They are useful in case of lack of space.



Three conductors through terminal blocks

They are most useful when wires with different construction, type and cross-section on the same circuit shall be jointed.



Four conductors through terminal blocks

They are most useful when wires with different construction, type and cross-section on the same circuit shall be jointed.

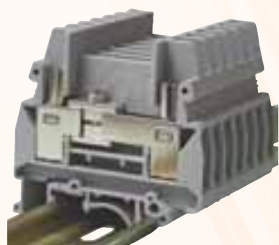

Testing terminal blocks

Besides keeping the electrical short-circuit rail open or closed they are enable to joint measuring equipments into the circuit parallel or serial At the TSKA6S type the measuring female terminal is suited for pressing the wire and also for fixing the connecting plug.



Terminal blocks for separation

They are applicable up to 16 A rated current. The disconnection knife is able to disconnect circuits up to 500 V rated voltage for measuring or disconnection purposes.

MEEI type test certificate No.:



D0601V101

RELEVANT STANDARD

EN 60947-7-1

RELEVANT STANDARD

EN 60947-7-2

MEEI type test certificate No.:



D0601V101



A/26

Terminal blocks

Accessories

SF marginal links

They are meant for connecting terminal blocks in the conductor's area. The marginal links are available in 2, 3 or 10 module version. The connecting part has a plastic cover to ensure enough electrical strength and safety.



USF central links

They are used to connect terminal blocks at their central part. Available in two-, three- and ten group pack up to TSKA50 size.



VL end plates

The end plates are used to close the Terminal block's end. It ensures enough insulation space in accordance of rated voltage and electrical safety between different size neighbor terminal blocks.



HL bridges

This links are suitable to connect non-adjacent terminal blocks. Electrical safety is ensured by the insulation body on the screw head. By overlapping the links more than 10 units can be connected.



EL insulating spaces

It provides electrical and visual separation between bridging links which can be inserted afterwards, too.

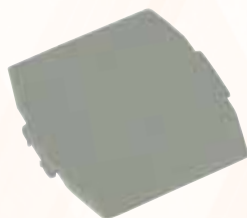

SZEL segment spaces

It provides electrical and visual separation between terminal blocks.



MAM measuring adapters

The leg of the measuring females of terminal blocks can be fixed by a metric thread into the hole on the middle of blocks thus enable to joint BDPS and BDMPS test plugs.



BDPS, BDMPS test plugs

They can be jointed directly into the test terminal blocks and via MAM measuring adapters into other kind of terminal blocks, too. The diameter of test plugs are at BDPS type 4 mm, at BDMPS type 2,3 mm.



FT warning boards

These boards give warning of electrical danger. It can be fixed with plastic screws onto terminal blocks. Depend on the width of board they can cover 3, 4 or 5 terminal blocks. The height of letters can be 6 or 8 mm.



KJ-A block markers

The marker is suitable to mark terminal blocks. It can be clipped on the RE1 type fixing element by slipping its legs into the properly formed gap. Size: 44x7 mm.

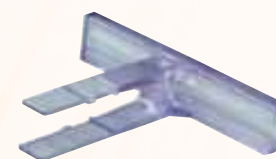

RE end brackets

They make possible to fix terminal blocks on mounting rails (35 / 7,5 mm size „hat” or 32 / 15 mm size „C” rail). They are recommended to use on both sides of blocks. At high current terminal blocks the RE2 type aluminum fixing element shall be used.



J mark bars

These mark bars are used for identification of terminal blocks. We offer mark bars in four different widths and in ten module unit.



MEEI type test certificate No.:



D0601V101

RELEVANT STANDARD

EN 60947-7-1

RELEVANT STANDARD

EN 60947-7-2

MEEI type test certificate No.:



D0601V101



Terminal blocks

Technical data

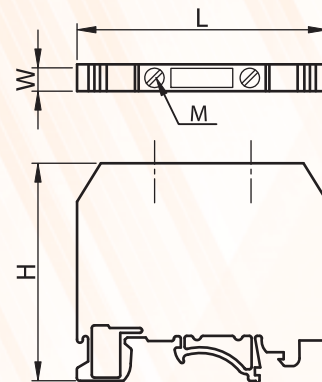
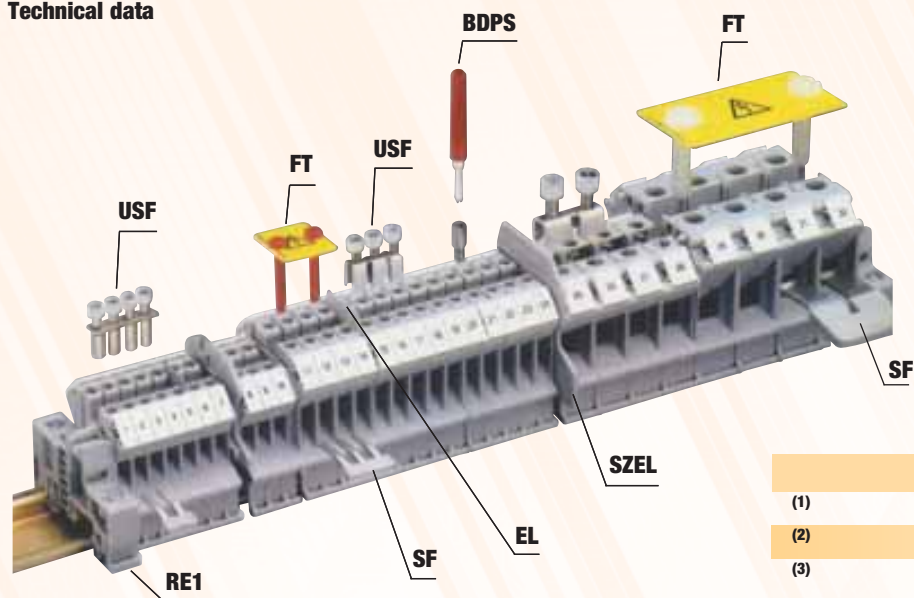

	2 modules	3 modules
(1)	USF35-2	USF35-3
(2)	USF50-2	USF50-3
(3)	The KJ-A block marker can be clip-on the RE1 type end bracket	

Tracon code	Terminal block type	U _n (V)	I _n (A)	Wire (mm ²)		Dimensions (mm)				Stripping length (mm)	Max. torque (Nm)	U central link 10 modules
				solid	twisted	W	L	H	M			
TSKA2,5	General	800	32	0,2-4	0,2-2,5	5,5	42	46	M3	8	0,5	USF2,5
TSKA4	General	800	41	0,2-6	0,2-4	6,5	42	46	M3	8	0,5	USF4
TSKA6	General	800	57	0,2-10	0,2-6	8,5	42,5	46	M4	10	1,2	USF6
TSKA10	General	800	76	0,5-16	0,5-10	10,2	42,5	46	M4	10	1,2	USF10
TSKA16	General	800	101	2,5-25	4-16	12,2	42,5	52,5	M4	11	1,2	USF16
TSKA35	General	1000	150	0,75-50	0,75-35	15,2	50	61	M6	16	2,5	USF35⁽¹⁾
TSKA50	High current	1000	150	16-50	25-50	20,5	71	76	M6	24	2,5	-⁽²⁾
TSKA95	High current	1000	232	25-95	35-95	25	83	90	M8	33	3,5	-
TSKA150	High current	1000	309	35-150	50-150	31	100	119	M10	40	4,0	-
TSKA240	High current	1000	415	70-240	70-240	36	100	131,5	M12	40	14	-
TSKA2,5-K	Neutral	800	32	0,2-4	0,2-2,5	5,5	43	47	M3	8	0,5	USF2,5
TSKA4-K	Neutral	800	41	0,2-6	0,2-4	6,5	43	46	M3	8	0,5	USF4
TSKA6-K	Neutral	800	57	0,2-10	0,2-6	8,3	43	46	M4	10	1,2	USF6
TSKA10-K	Neutral	800	76	0,5-16	0,5-10	10,5	43	47	M4	10	1,2	USF10
TSKA16-K	Neutral	800	101	2,5-25	4-16	12,5	42,5	53	M4	11	1,2	USF16
TSKA35-K	Neutral	1000	150	0,75-50	0,75-35	15,7	51	62	M6	16	2,5	USF35⁽¹⁾
TSKA50-K	H.C., neutral	1000	150	16-50	25-50	20,5	71	76	M6	24	2,5	-⁽²⁾
TSKA95-K	H.C., neutral	1000	232	25-95	35-95	25	83	90	M8	33	3,5	-
TSKA150-K	H.C., neutral	1000	309	35-150	50-150	31,5	101	112	M10	40	4,0	-
TSKA240-K	H.C., neutral	1000	415	70-240	70-240	36	100	131,5	M12	40	14	-
TSKA2.5JD	PE	-	32	0,2-4	0,2-2,5	5,5	42,5	45,5	M3	8	0,5	-
TSKA4JD	PE	-	41	0,2-6	0,2-4	6,5	43	46	M3	8	0,5	-
TSKA6JD	PE	-	57	0,2-10	0,2-6	8,5	43	46	M4	10	1,2	-
TSKA10JD	PE	-	76	0,5-16	0,5-10	10,5	43	45,5	M4	10	1,2	-
TSKA16JD	PE	-	101	2,5-25	4-16	12,5	43	52,5	M4	11	1,2	-
TSKA35JD	PE	-	150	0,75-50	0,75-35	16	55	51	M6	16	2,5	-
TSKA50JD	PE	-	150	16-50	25-50	20,5	71	77	M6	24	2,5	-
TSKA2,5/2	Double-deck	500	32	0,2-4	0,2-2,5	5,5	56,5	62	M3	8	0,5	-
TSKA4/2	Double-deck	500	32	0,2-4	0,2-4	6,5	56,5	61	M3	8	0,5	USF4
TSKA4/3	Three-contact	500	32	0,2-4	0,2-4	6,5	50	46	M3	8	0,5	USF4
TSKA4/4	Four-contact	690	32	0,2-6	0,2-4	6,5	63,5	46	M3	8	0,5	USF4
TSKA4LEV	Separate	500	16	0,2-4	0,2-4	6,5	51,5	47	M3	8	0,5	-
TSKA6S	Measuring	400	57	0,5-10	0,5-6	8,5	72,5	51	M4	13	1,2	-
TSKA6S/2	Measuring	500	57	0,5-10	0,5-6	8,5	61,5	58	M3	8	0,5	-





Terminal blocks



A

General, neutral

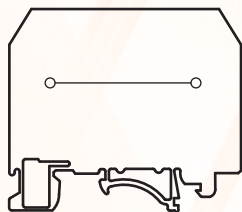

Measuring, separate

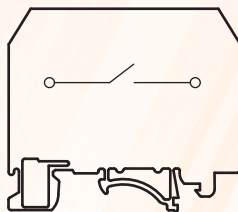

Three-contact

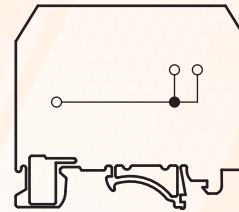

PE

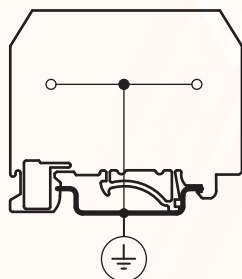

Double-deck

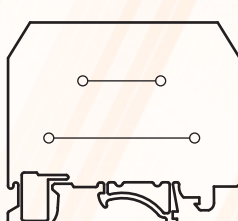

Four-contact

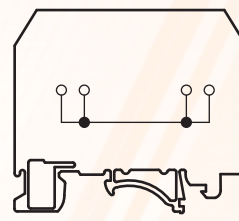

Marginal link			End plate	Bridging link	Circuit spacer	Segment spacer	Measuring adaptor	Mark bars	Warning board			Test plug	End bracket ⁽³⁾
2 modules	3 modules	10 modules							3 modules	4 modules	5 modules		
SF102	SF103	SF100	VL4/10	-	EL102	SZEL101	MAM3	J5	-	-	-	BDMPS	RE1
SF112	SF113	SF110	VL4/10	HL4	EL102	SZEL101	MAM3	J6	FT6-3	FT6-4	FT6-5	BDMPS	RE1
SF122	SF123	SF120	VL4/10	HL6	EL102	SZEL101	MAM4	J8	FT8-3	FT8-4	FT8-5	BDPS	RE1
SF132	SF133	SF130	VL4/10	HL10	EL102	SZEL101	MAM4	J10	-	-	-	BDPS	RE1
-	-	SF140	VL16	-	EL102	SZEL101	MAM4	J10	-	-	-	BDPS	RE1
-	-	SF150	-	-	EL102	-	MAM6	J10	-	-	-	BDPS	RE1
-	-	-	-	-	-	-	-	J10	-	-	-	-	RE2
SF162	SF163	-	-	-	-	-	-	J10	-	-	-	-	RE2
SF172	SF173	-	-	-	-	-	-	J10	-	-	-	-	RE2
-	-	-	-	-	-	-	-	J10	-	-	-	-	RE2
SF102	SF103	SF100	VL4/10	-	EL102	SZEL101	MAM3	J5	-	-	-	BDMPS	RE1
SF112	SF113	SF110	VL4/10	HL4	EL102	SZEL101	MAM3	J6	FT6-3	FT6-4	FT6-5	BDMPS	RE1
SF122	SF123	SF120	VL4/10	HL6	EL102	SZEL101	MAM4	J8	FT8-3	FT8-4	FT8-5	BDPS	RE1
SF132	SF133	SF130	VL4/10	HL10	EL102	SZEL101	MAM4	J10	-	-	-	BDPS	RE1
-	-	SF140	VL16	-	EL102	SZEL101	MAM4	J10	-	-	-	BDPS	RE1
-	-	SF150	-	-	EL102	-	MAM6	J10	-	-	-	BDPS	RE1
-	-	-	-	-	-	-	-	J10	-	-	-	-	RE2
SF162	SF163	-	-	-	-	-	-	J10	-	-	-	-	RE2
SF172	SF173	-	-	-	-	-	-	J10	-	-	-	-	RE2
-	-	-	-	-	-	-	-	J10	-	-	-	-	RE2
-	-	-	-	-	-	-	-	J10	-	-	-	-	RE2
-	-	-	-	-	-	-	-	J5	-	-	-	-	RE1
-	-	-	-	-	-	-	-	J6	-	-	-	-	RE1
-	-	-	-	-	-	-	-	J8	-	-	-	-	RE1
-	-	-	-	-	-	-	-	J10	-	-	-	-	RE1
-	-	-	-	-	-	-	-	J10	-	-	-	-	RE1
-	-	-	-	-	-	-	-	J10	-	-	-	-	RE1
-	-	-	-	-	-	-	-	J10	-	-	-	-	RE1
-	-	-	-	-	-	-	-	J10	-	-	-	-	RE2
-	-	-	VL3/5	-	EL101	SZEL102	-	J5	-	-	-	-	RE1
SF112	SF113	SF110	VL3/5	HL4	EL101	SZEL102	-	J6	FT6-3	FT6-4	FT6-5	BDMPS	RE1
SF112	SF113	SF110	VL4/3	HL4	EL102	-	MAM3	J6	FT6-3	FT6-4	FT6-5	BDMPS	RE1
SF112	SF113	SF110	VL4/4	HL4	EL101	-	-	J6	FT6-3	FT6-4	FT6-5	BDMPS	RE1
SF112	SF113	SF110	-	-	-	SZEL106	-	J6	-	-	-	BDMPS	RE1
-	-	-	VL6S	-	EL105	SZEL105	-	J8	-	-	-	BDPS	RE1
SF122	SF123	SF120	VL6S/2	-	EL104	SZEL104	-	J8	-	-	-	BDPS	RE1





Terminal blocks



A

TSKB spring (no screw) terminal blocks

The spring terminal blocks were designed mainly for jointing control circuit wires in 0,2 mm²- 6,0 mm² cross-section range in good quality, quick and reliable way. The terminal block can accommodate unprepared rigid wires, or twisted or flexible wires equipped with cord-end terminals or male lugs. The highly heat resistant, strong, self-extinguishing (according to UL94-V0) polyamide plastic house with good electrical parameters – witch contains the electrical elements - , is shaped in a way to permit the terminal block to be fixed onto mounting rails according standard EN 50022 („hat” or „C” rail).

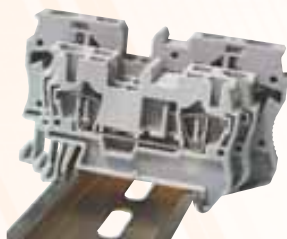

General purpose terminal blocks

They enabled to joint wires in 1,5 mm² - 6 mm² cross-section on space-saving, upwards way. The contact is ensured by spring placed inside the block. To release the joint push the spring with a screwdriver.

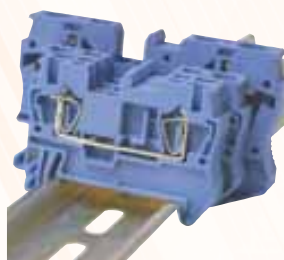

Neutral conductor terminal blocks

They have same construction as the general purpose terminal blocks, however due to its blue color plastic house is suited for jointing the neutral conductor, being visually different from the phase conductor.



Protective conductor terminal blocks

They are suitable to make electrical and mechanical connection between PE conductors and the grounded mounting rail. The terminal blocks are also suited to joint PEN and PE conductors. General, three- and four-contact versions are also available.



Double-deck terminal blocks

They are suitable for jointing wires of two separated circuits. Due to proper construction of plastic house the two terminal levels can be easy handled by a screwdriver. They are useful in case of lack of space. They are available in neutral conductor version (blue), too.

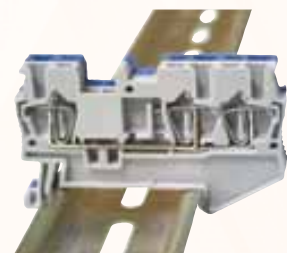

Three conductors through terminal blocks

They are most useful when wires with different construction, type and cross-section on the same circuit shall be jointed. They are available in neutral conductor version (blue), too.



Four conductors through terminal blocks

They are most useful when wires with different construction, type and cross-section on the same circuit shall be jointed. They are available in neutral conductor version (blue), too.



Potential distribution terminal block

In this terminal block the conductive rails are connected with a wire inside of device. Similarly to the four-conductor trough terminal block it can be used for potential distribution, while even smaller place is required.

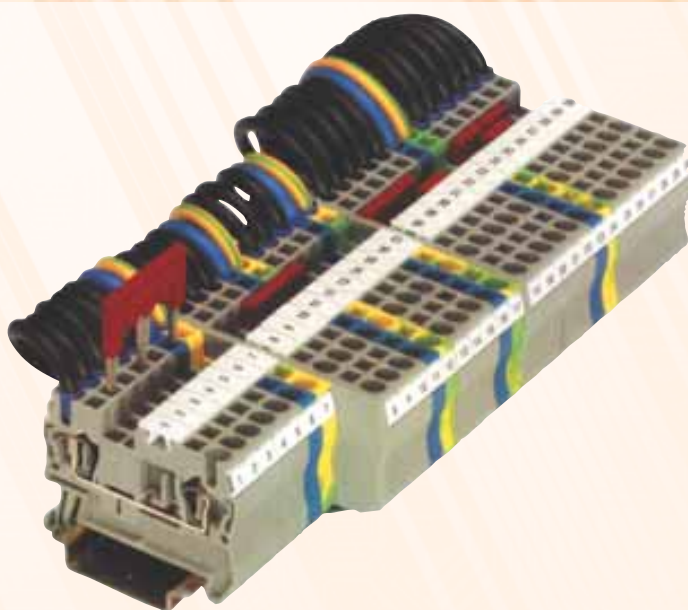

RELEVANT STANDARD

EN 60947-7-1

RELEVANT STANDARD

EN 60947-7-2



A/30

Tracon Budapest Ltd. • Pallag Street 23, Dunakeszi, H-2120, Hungary

Tel.: +36-27-540-000, Fax: +36-27-540-005 • Website: www.traconelectric.com • E-mail: tracon@tracon.hu



Terminal blocks



A

Accessories

AH... bridging links

They are available in 2, 3, and 10 module versions. With help of two modules bridging link any number of blocks can be connected. With help of three and ten module plugs the installation time can be reduced, because ten modules can be connected with one movement.



VLB end plates

The end plates are used to close the Terminal block's end. It ensures enough insulation space in accordance of rated voltage and electrical safety between different size neighbor terminal blocks.

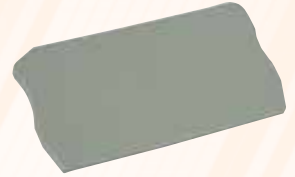

ELB separation plates

It provides electrical and visual separation between bridging links which can be inserted afterwards, too.



J and JBO mark bars

By help of these bars the blocks can be marked from above (J) or from side (JBO). This way the identification of blocks is easier during installation or maintenance. The size of the mark bars fits with the size of blocks.



EKB test female

Designed for easier measurement and checking of the circuit. Safe measurement can be done by plugging it into bridging gap.



KJ-A block marker

The marker is suitable to mark terminal blocks. It can be clipped on the REB type fixing element by slipping its legs into the properly formed gap. Size: 44x7 mm.



REB end brackets

They make possible to fix terminal blocks on mounting rails (35 / 7,5 mm size „hat” or 32 / 15 mm size „C” rail). They are recommended to use on both sides of blocks.



RELEVANT STANDARD

EN 60947-7-2

RELEVANT STANDARD

EN 60947-7-1

The conductor to be jointed (3) is pressed by the steel spring (1) onto the tinned copper conductive rail (2). For jointing the wire the spring should be adjusted with a simple screwdriver into the jointing position, so the conductor can be plugged into a gap on the spring. After removing the screwdriver the spring presses the wire against the rail with the necessary force. This spring force ensures smooth contact with the same quality as usual with screw terminal blocks. To disconnect the jointed wire the pressing force should be annihilated by pushing the spring again with a screwdriver as above; afterwards the wire can be pulled out from the terminal block.

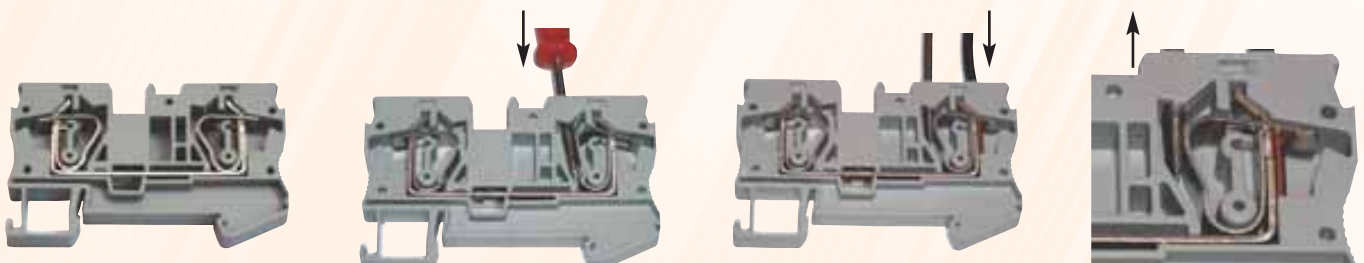
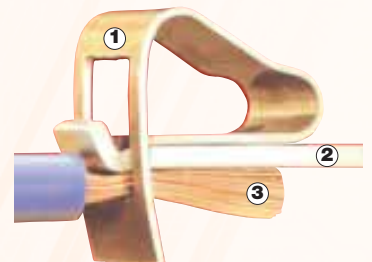

Terminal blocks

A

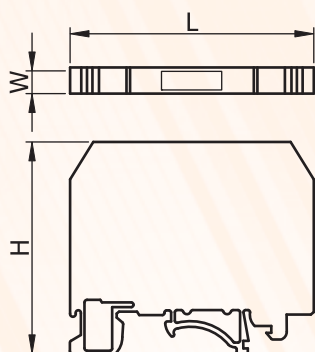

General, neutral

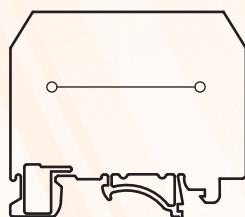

Double deck

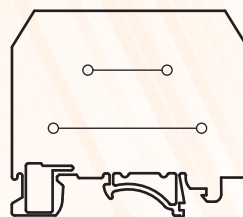

Three contacts

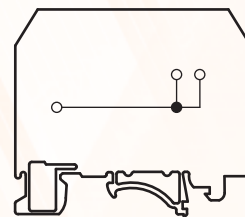

Technical data

Tracon code	Terminal block type	Rated voltage (V)	Rated current (A)	Wire (mm ²)		Sizes (mm)		
				solid	twisted	W	L	H
TSKB1,5	General	500	17.5	0.14-1.5	0.14-1.5	4,3	48,8	35,5
TSKB2,5	General	800	31	0.2-4	0.2-2.5	5,3	48,8	35,5
TSKB4	General	800	40	0.5-6	0.5-4	6,3	56	35,5
TSKB6	General	800	52	0.5-10	0.5-6	8,3	69,7	42,5
TSKB1,5K	Neutral	500	17.5	0.14-1.5	0.14-1.5	4,3	48,8	35,5
TSKB2,5K	Neutral	800	31	0.2-4	0.2-2.5	5,3	48,8	35,5
TSKB4K	Neutral	800	40	0.5-6	0.5-4	6,3	56,5	35,5
TSKB6K	Neutral	800	52	0.5-10	0.5-6	8,3	70	43
TSKB1/3	Three contacts	500	17.5	0.14-2.5	0.14-1.5	4,3	60,5	35,5
TSKB2/3	Three contacts	800	31	0.2-4	0.2-2.5	4,3	60,5	35,5
TSKB4/3	Three contacts	800	41	0.5-6	0.5-4	6,3	71,5	45,5
TSKB1/3K	Three contacts, neutral	500	17.5	0.14-2.5	0.14-1.5	4,3	60,5	36,5
TSKB2/3K	Three contacts, neutral	800	31	0.2-4	0.2-2.5	4,3	60,5	35,5
TSKB4/3K	Three contacts, neutral	800	41	0.5-6	0.5-4	6,3	71,5	36,5
TSKB1/4	Four contacts	500	17.5	0.14-2.5	0.14-1.5	4,3	72	36,5
TSKB2/4	Four contacts	800	28	0.2-4	0.2-2.5	5,3	72	36,5
TSKB4/4	Four contacts	800	40	0.2-6	0.2-4	6,3	87	36,5
TSKB1/4K	Four contacts, neutral	500	17.5	0.14-2.5	0.14-1.5	4,3	72	36,5
TSKB2/4K	Four contacts, neutral	800	28	0.2-4	0.2-2.5	5,3	72	36,5
TSKB4/4K	Four contacts, neutral	800	40	0.2-6	0.2-4	6,3	87	36,5
TSKB1/E	Double deck	500	17.5	0.14-1.5	0.14-1.5	4,3	67,5	47,5
TSKB2/E	Double deck	500	26	0.2-4	0.2-2.5	5,3	67,5	47,5
TSKB4/E	Double deck	500	32	0.2-6	0.2-4	6,3	83,5	47,5
TSKB1/EK	Double deck, neutral	500	17.5	0.14-1.5	0.14-1.5	4,3	67,5	47,5
TSKB2/EK	Double deck, neutral	500	26	0.2-4	0.2-2.5	5,3	67,5	47,5
TSKB4/EK	Double deck, neutral	500	32	0.2-6	0.2-4	6,3	83,5	47,5
TSKB1P	Potential distributor	500	17.5	0.14-1.5	0.14-1.5	4,3	67,5	47,5
TSKB2P	Potential distributor	500	26	0.2-4	0.2-2.5	5,3	67,5	47,5
TSKB4P	Potential distributor	500	32	0.2-6	0.2-4	6,3	83,5	47,5
TSKB1,5JD	PE	-	17.5	0.14-1.5	0.14-1.5	4,3	48,8	36,5
TSKB2,5JD	PE	-	31	0.2-4	0.2-2.5	5,3	48,8	35,5
TSKB4JD	PE	-	41	0.5-6	0.5-6	6,3	55,9	35,5
TSKB6JD	PE	-	57	0.5-10	0.5-6	8,4	69,5	42,5
TSKB1JD/3	Three contacts, PE	-	17.5	0.14-1.5	0.14-1.5	4,3	60,5	36,5
TSKB2JD/3	Three contacts, PE	-	31	0.2-4	0.2-2.5	5,3	60,5	36,5
TSKB4JD/3	Three contacts, PE	-	41	0.2-6	0.2-4	6,3	71,5	36,5
TSKB1JD/4	Four contacts, PE	-	17.5	0.14-1.5	0.14-1.5	4,3	72	36,5
TSKB2JD/4	Four contacts, PE	-	30	0.2-4	0.2-2.5	5,3	72	36,5
TSKB4JD/4	Four contacts, PE	-	40	0.2-6	0.2-4	6,3	87	36,5





Terminal blocks



A

Four contacts

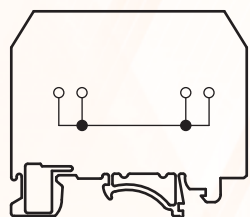

PE

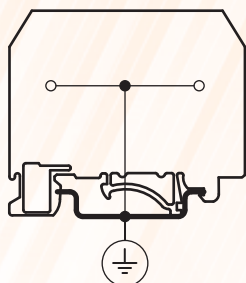

Three contacts, PE

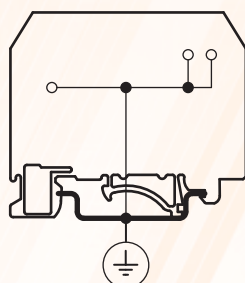

Four contacts, PE

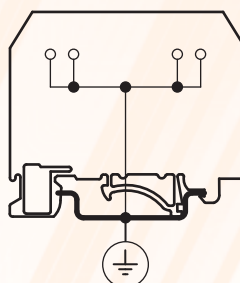

Potential distributor

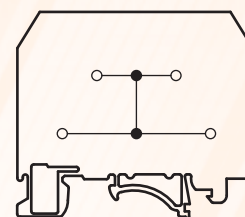

Stripping length (mm)	End plate	Bridging links			Separating plates	Marker* 10 pcs.		Test female	Block marker	End brocket
		2 modules	3 modules	10 modules		middle	side			
10	VLB2	AH1,5/2	AH1,5/3	AH1,5/10	ELB	J5	JB04	EKB	KJ-A	REB
10	VLB2	AH2,5/2	AH2,5/3	AH2,5/10	ELB	J6	JB05	EKB	KJ-A	REB
12	VLB4	AH4/2	AH4/3	AH4/10	ELB	J8	JB06	EKB	KJ-A	REB
12	VLB6	AH6/2	AH6/3	AH6/10	ELB	J10	JB08	EKB	KJ-A	REB
10	-	AH1,5/2	AH1,5/3	AH1,5/10	-	J5	JB04	EKB	KJ-A	REB
10	-	AH2,5/2	AH2,5/3	AH2,5/10	-	J6	JB05	EKB	KJ-A	REB
12	-	AH4/2	AH4/3	AH4/10	-	J8	JB06	EKB	KJ-A	REB
12	-	AH6/2	AH6/3	AH6/10	-	J10	JB08	EKB	KJ-A	REB
10	VLB2/3	AH1,5/2	AH1,5/3	AH1,5/10	ELB/3	J5	JB04	EKB	KJ-A	REB
10	VLB2/3	AH2,5/2	AH2,5/3	AH2,5/10	ELB/3	J6	JB05	EKB	KJ-A	REB
12	VLB4/3	AH4/2	AH4/3	AH4/10	ELB/3	J8	JB06	EKB	KJ-A	REB
10	-	AH1,5/2	AH1,5/3	AH1,5/10	-	J5	JB04	EKB	KJ-A	REB
10	-	AH2,5/2	AH2,5/3	AH2,5/10	-	J6	JB05	EKB	KJ-A	REB
12	-	AH4/2	AH4/3	AH4/10	-	J8	JB06	EKB	KJ-A	REB
10	VLB2/4	AH1,5/2	AH1,5/3	AH1,5/10	ELB/4	J5	JB04	EKB	KJ-A	REB
10	VLB2/4	AH2,5/2	AH2,5/3	AH2,5/10	ELB/4	J6	JB05	EKB	KJ-A	REB
12	VLB4/4	AH4/2	AH4/3	AH4/10	ELB/4	J8	JB06	EKB	KJ-A	REB
10	-	AH1,5/2	AH1,5/3	AH1,5/10	-	J5	JB04	EKB	KJ-A	REB
10	-	AH2,5/2	AH2,5/3	AH2,5/10	-	J6	JB05	EKB	KJ-A	REB
12	-	AH4/2	AH4/3	AH4/10	-	J8	JB06	EKB	KJ-A	REB
10	VLB2/E	AH1,5/2	AH1,5/3	AH1,5/10	ELB/E	J5	JB04	EKB	KJ-A	REB
10	VLB2/E	AH2,5/2	AH2,5/3	AH2,5/10	ELB/E	J6	JB05	EKB	KJ-A	REB
12	VLB4/E	AH4/2	AH4/3	AH4/10	ELB/E	J8	JB06	EKB	KJ-A	REB
10	-	AH1,5/2	AH1,5/3	AH1,5/10	-	J5	JB04	EKB	KJ-A	REB
10	-	AH2,5/2	AH2,5/3	AH2,5/10	-	J6	JB05	EKB	KJ-A	REB
12	-	AH4/2	AH4/3	AH4/10	-	J8	JB06	EKB	KJ-A	REB
10	VLB2/E	AH1,5/2	AH1,5/3	AH1,5/10	ELB/E	J5	JB04	EKB	KJ-A	REB
10	VLB2/E	AH2,5/2	AH2,5/3	AH2,5/10	ELB/E	J6	JB05	EKB	KJ-A	REB
12	VLB4/E	AH4/2	AH4/3	AH4/10	ELB/E	J8	JB06	EKB	KJ-A	REB
10	-	-	-	-	-	J5	JB04	EKB	KJ-A	REB
10	-	-	-	-	-	J6	JB05	EKB	KJ-A	REB
12	-	-	-	-	-	J8	JB06	EKB	KJ-A	REB
12	-	-	-	-	-	J10	JB08	EKB	KJ-A	REB
10	-	-	-	-	-	J5	JB04	EKB	KJ-A	REB
10	-	-	-	-	-	J6	JB05	EKB	KJ-A	REB
12	-	-	-	-	-	J8	JB06	EKB	KJ-A	REB
10	-	-	-	-	-	J5	JB04	EKB	KJ-A	REB
10	-	-	-	-	-	J6	JB05	EKB	KJ-A	REB
12	-	-	-	-	-	J8	JB06	EKB	KJ-A	REB

